



- Measuring ranges:  
3-27 to 300-2300 l/min. water  
6-42 to 500-2800 Nm<sup>3</sup>/h air
- p<sub>max</sub>: PN 40
- t<sub>max</sub>: 100 °C
- Connection:  
G 1/2 to G 3, 1/2 NPT to 3 NPT
- Material:  
aluminium bronze and  
stainless steel



KOBOLD offices exist in the following countries:

ARGENTINA, AUSTRIA, BELGIUM, BRAZIL, CANADA,  
CHINA, COLOMBIA, FRANCE, GREAT BRITAIN, NETHERLANDS,  
POLAND, SWITZERLAND, USA, VENEZUELA

KOBOLD Messring GmbH  
Nordring 22-24  
D-65719 Hofheim/Ts.  
☎ (06192) 299-0  
Fax (06192) 23398  
E-mail: info.de@kobold.com  
Internet: www.kobold.com

Model:  
RCD



**Description**

The KOBOLD flow meter model RCD is used for measuring and monitoring liquid and gas flows. The device works on the well-known principle of the Venturi nozzle. A small pressure difference proportional to the flow is produced by the flowing medium at an orifice constriction (nozzle) in the device housing. The shape of the nozzle is based on the flow, whereby the flow characteristic remains constant over

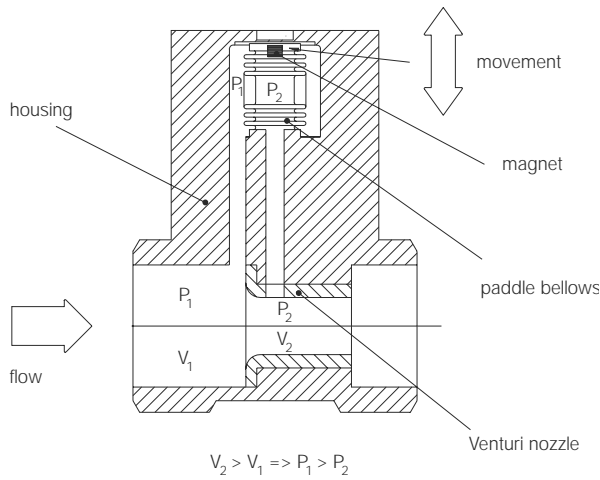

the entire measuring range. Drill holes are located in the housing fitting to absorb the resulting differential pressure and transfer it to a differential-pressure measuring cell fitted in the display case. If the flow is exceeded the differential-pressure measuring cell is protected by locking pins. On mechanical displays the flow rate measured by the pressure measuring cell is transferred via a pointer movement to the pointer indicator calibrated in l/min water or Nm<sup>3</sup>/h air. On electronic displays the mechanical motion is converted to an electrical signal by a Hall-sensor. Various electronic modules are then used to display and monitor the volumetric flow. Special scales are available for all media at any pressure and any temperature.

**Areas of Application**

- machinery and equipment manufacturing
- chemical and pharmaceutical industries
- heavy industry
- beverage and semi-luxury food industry

**Special advantages**

- no moving parts
- mounting independant
- self-monitoring of measuring system
- Easy to use

**Technical details**

Measuring accuracy: 3% f.s.  
 Repeatability: 1% f. meas. value  
 Process temperature: RCD...mechanical: 100 °C  
 RCD...electronic: 80 °C  
 Ambient temperature.: max. 80 °C  
 Max. operating pressure: 25 bar (RCD-1155.. - RCD-1165...)  
 PN 40/20 °C (all others)  
 Protection: IP 65

**Materials:**

Display case: cast aluminium  
 Front cover: polycarbonate  
 Fluidic casing: RCD-x1...: aluminium bronze  
 RCD-x2...: stainless steel 1.4581

Differential pressure housing: RCD-x1...: aluminium bronze  
 RCD-x2...: stainless steel 1.4571

Pressure measuring cell: stainless steel 1.4571

Venturi nozzle: stainless steel 1.4571

Seals: RCD-x1...: NBR  
 RCD-x2...: FPM

**Displays/electronics:**

● **Mechanical pointer indicator:**

Display: 270 °  
 Option: special scales for other gases and liquids. Please specify measured medium, density, viscosity, operating pressure and temperature

● **Compact electronics:**

Display: 3-digit LED  
 Analogue output: (0)4 - 20 mA adjustable, max. 500 Ω  
 Switching outputs: 1 (2) semiconductor PNP or NPN, factory set  
 Contact operation: N/C / N/O / frequency programmable  
 Setting: via 2 buttons  
 Supply: 24 V<sub>DC</sub> ± 20%, 3-wire, approx. 100 mA  
 Electrical connection: plug connector M12 x 1

● **ADI electronics**

Display: bar graph, 3.5-digit digital-display  
 Analogue output: (0)4 - 20 mA, 0-10 V, scalable pulse output 0-1000 Hz  
 Two switching outputs: two relay/changeover contacts  
 max. 230 V<sub>AC</sub>, 5 A resistive load  
 max. 30 V<sub>DC</sub> / 5 A  
 Option: two optocouplers  
 max. 35 V<sub>DC</sub>, I = 10 - 50 mA  
 Setting: via 3 buttons  
 Supply: 230/115/48/24 V<sub>AC</sub>, 24 V<sub>DC</sub>  
 Electrical connection: pluggable terminal block via PG cable gland

See brochure Z2 for more technical details on ADI evaluating electronics



**Order details** (example: RCD 1105H G4 B 0 0 0)

Measuring range L/min Water	Model		Connection	
	Material Aluminium bronze	Material stainless steel	Standard	Special
3-27 5-40	RCD 1105H.. RCD 1110H..	RCD 1205H.. RCD 1210H..	G4= G 1/2	N4= 1/2 NPT
10-65 10-80	RCD 1115H.. RCD 1120H..	RCD 1215H.. RCD 1220H..	G5= G 3/4	N5= 3/4 NPT
20-130 20-160	RCD 1125H.. RCD 1130H..	RCD 1225H.. RCD 1230H..	G6= G 1	N6= 1 NPT
30-270 60-420	RCD 1135H.. RCD 1140H..	RCD 1235H.. RCD 1240H..	G8= G 1 1/2	N8= 1 1/2
100-700 100-900	RCD 1145H.. RCD 1150H..	RCD 1245H.. RCD 1250H..	G9= G 2	N9= 2 NPT
100-1000 200-1500	RCD 1155H.. RCD 1160H..	RCD 1255H.. RCD 1260H..	GB= G 3	NB= 3 NPT
300-2300	RCD 1165H..	RCD 1265H..	GB= G 3	NB= 3 NPT

Evaluating electronics			
Mechanical pointer indicator			
Display	Flow direction	Locat. of display	
Z= pointer indicator, 270°	L= from left R= from right B= from bottom	L= left R= right T= top B=bottom	
ADI electronics**			
Display	Supply	Output	Contacts
K= Bargr./digital	0= 230 V <sub>AC</sub> 4= 115 V <sub>AC</sub> 2= 24 V <sub>AC</sub> 1= 48 V <sub>AC</sub> 3= 24 V <sub>DC</sub>	0= without F= scalable frequency 1= 0-10 V 2= 0-20 mA 4= 4-20 mA	0= without 2= 2 change-over contacts 6= 2 opto-couplers
Compact electronics**			
Display	Supply	Output/contacts	
C= Digital	3= 24 V <sub>DC</sub>	0R= 2 x open collector, PNP 0M= 2 x open collector, NPN 4P= 4-20 mA, 1 x open coll. PNP 4N= 4-20 mA; 1 x open coll. NPN	

**Order details** (example: RCD 1105L G4 B 0 0 0)

Measuring range Nm <sup>3</sup> /h <sup>*</sup> air	Model		Connection	
	Material Aluminium bronze	Material stainless steel	Standard	Special
6-42 10-65	RCD 1105L.. RCD 1110L..	RCD 1205L.. RCD 1210L..	G4= G 1/2	N4= 1/2 NPT
15-95 20-115	RCD 1115L.. RCD 1120L..	RCD 1215L.. RCD 1220L..	G5= G 3/4	N5= 3/4 NPT
30-190 30-220	RCD 1125L.. RCD 1130L..	RCD 1225L.. RCD 1230L..	G6= G 1	N6= 1 NPT
75-375 100-600	RCD 1135L.. RCD 1140L..	RCD 1235L.. RCD 1240L..	G8= G 1 1/2	N8= 1 1/2
150-900 200-1100	RCD 1145L.. RCD 1150L..	RCD 1245L.. RCD 1250L..	G9= G 2	N9= 2 NPT
250-1300 300-2000	RCD 1155L.. RCD 1160L..	RCD 1255L.. RCD 1260L..	GB= G 3	NB= 3 NPT
500-2800	RCD 1165L..	RCD 1265L..	GB= G 3	NB= 3 NPT

Evaluating electronics			
Mechanical needle indication			
Display	Flow direction	Locat. of display	
Z= pointer indicator, 270°	L= from left R= from right B= from bottom	L= left R= right T= top B= bottom	
ADI electronics**			
Display	Supply	Output	Contacts
K= Bargr./Digital	0= 230 V <sub>AC</sub> 4= 115 V <sub>AC</sub> 2= 24 V <sub>AC</sub> 1= 48 V <sub>AC</sub> 3= 24 V <sub>DC</sub>	0= without F= scalable frequency 1= 0-10 V 2= 0-20 mA 4= 4-20 mA	0= without 2= 2 change-over contacts 6= 2 opto-couplers
Compact electronics**			
Display	Supply	Output/contacts	
C= Digital	3= 24 V <sub>DC</sub>	0R= 2 x open collector, PNP 0M= 2 x open collector, NPN 4P= 4-20 mA, 1 x open coll. PNP 4N= 4-20 mA; 1 x open coll. NPN	

\* 20 °C, 0 bar rel.

\*\* Please specify flow direction (not from top to bottom) in plain text.

**Dimensions**

RCD...Z with mechanical display

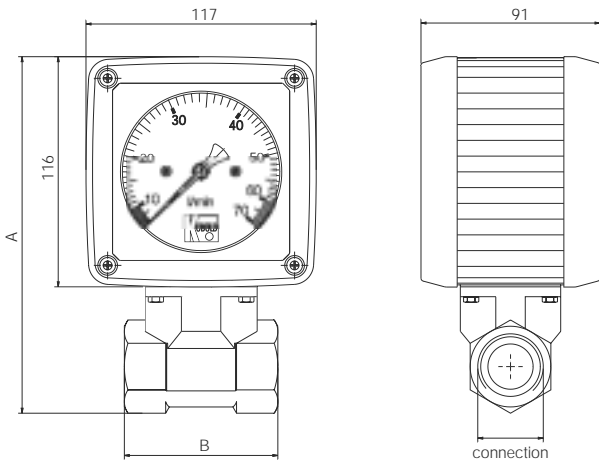

Thread	A	B	C	D	Weight
G 1/2	191	78	hex 27	143	app. 2.0 kg
G 3/4	191	78	hex 41	143	app. 2.3 kg
G 1	191	78	hex 41	143	app. 2.2 kg
G 1 1/2	206	78	hex 55	158	app. 2.6 kg
G 2	204	81	hex 70	156	app. 2.8 kg
G 3	221	106	hex 100	173	app. 5.1 kg

DPT...C with compact electronics

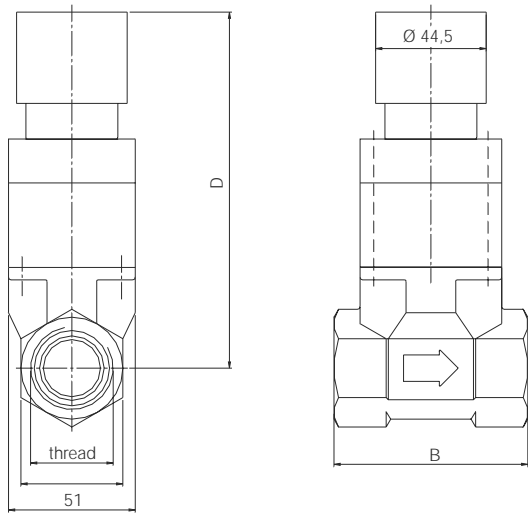

Thread	A	B	C	D	Weight
G 1/2	191	78	hex 27	143	app. 2.1 kg
G 3/4	191	78	hex 41	143	app. 2.4 kg
G 1	191	78	hex 41	143	app. 2.2 kg
G 1 1/2	206	78	hex 55	158	app. 2.6 kg
G 2	204	81	hex 70	156	app. 2.9 kg
G 3	221	106	hex 100	173	app. 5.2 kg

RCD...K with ADI electronics

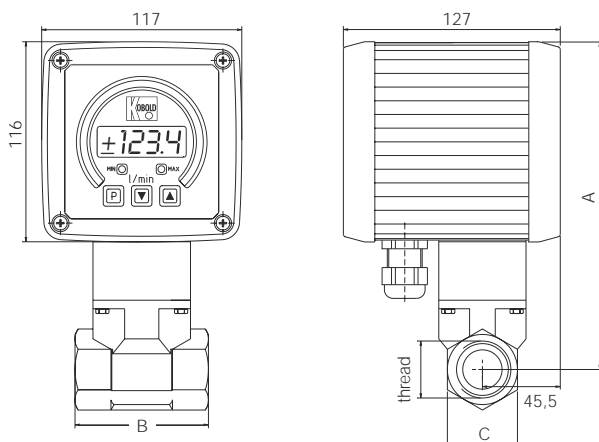

Thread	A	B	C	D	Weight
G 1/2	191	78	hex 27	143	app. 3.4 kg
G 3/4	191	78	hex 41	143	app. 3.7 kg
G 1	191	78	hex 41	143	app. 3.6 kg
G 1 1/2	206	78	hex 55	158	app. 3.9 kg
G 2	204	81	hex 70	156	app. 4.2 kg
G 3	221	106	hex 100	173	app. 6.5 kg