

# Mass Flow Meter and Controller for gases



Flow  
Pressure  
Level  
Temperature  
measurement  
monitoring  
control



- Direct indication
- Digital indication
- Bypass measuring for generating laminar flow

Model:  
MAS  
MFC

**Fields of application:**

The KOBOLD MAS model mass flow meter makes very precise measurements of the mass flow rate of gases in different measuring ranges from 0 - 10 Ncm<sup>3</sup>/min to 0 - 500 NI/min nitrogen. The operation of the meter is based on the calorimetric principle. For indication of 98 % of the actual flow, the response time is 2 s. The meter may be installed in any position.

In contrast with most volumetric flowmeters, no temperature or pressure correction is required.

This means that the MAS model is ideally suited for almost every gas flow application. Typical industrial applications are process control, laboratory measuring tasks, OEM applications, gas indication panels, leakage and filter monitoring.

The MAS is available either with analog output only, or in addition with digital indication. The 3 1/2-position LCD display is infinitely rotatable through 180°. It is also available upon request with a 1.5 m long connection cable for wall mounting. Glass-fibre-reinforced nylon or stainless steel may be used in the manufacture of wetted parts. Packing materials is FPM (Kalrez or Neopron upon request). The MAS model may be operated with 12-15 VDC (24 VDC optional). MAS 5100 or MAS 8100 are recommended as power supplies. Typically, a 0-5 VDC (or 4-20 mA optional) analog signal is available as output signal. This allows recording, data storage, and control functions to be implemented.

**Design**

**Direct indication of mass flow rate**

No temperature or pressure correction needed

**Tilting indicator**

May be tilted through 180°, 9 adjustments

**Output plug connector**

9 Pin »D« Sub-type, Output signal 0-5 V DC or 4-20 mA optional analog output

**Mains plug**

Input voltage 12 or 24 V DC

**Pipe unions**

with 1/4" FNPT or 1/4" Swagelok connections

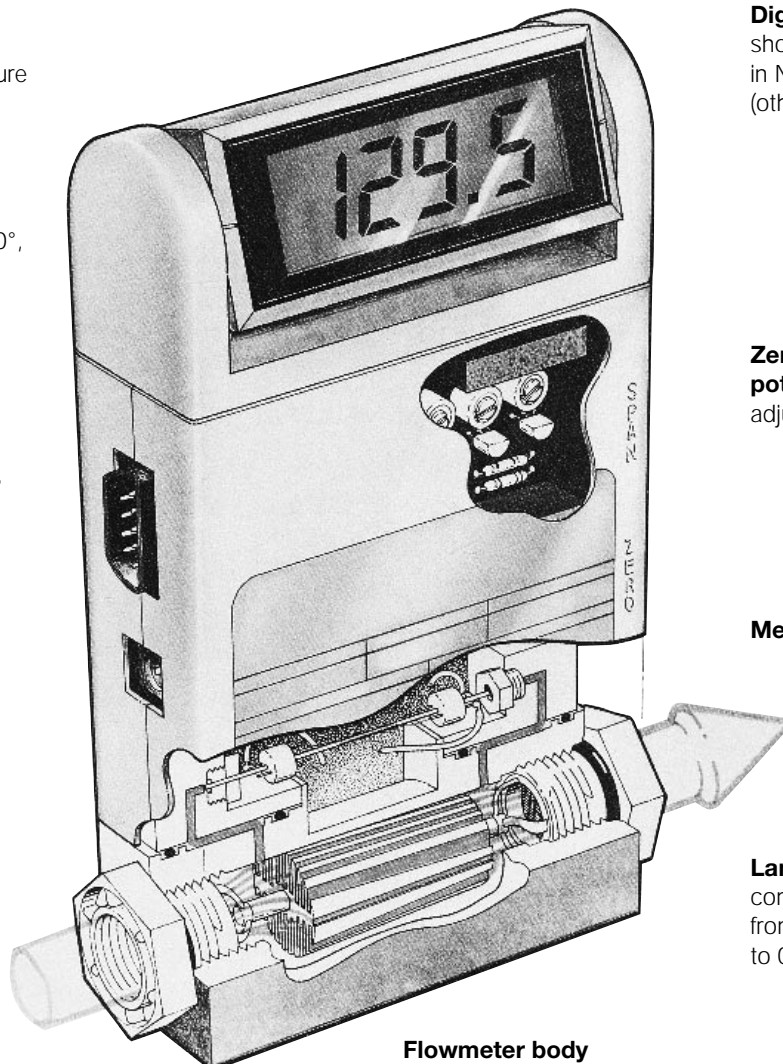

**Digital indicator**

shows the mass flow rate in Ncm<sup>3</sup>/min or NI/min (other units upon request)

**Zero-point and span potentiometers**

adjustable from outside

**Measuring tube**

**Laminar flow bypass**

comes in 13 ranges from 0-10 Ncm<sup>3</sup>/min to 0-500 NI/min

**Flowmeter body**

Wetted parts either nylon or steel



**Theory of operation:**

The medium flows through the bypass measuring system. The resulting differential pressure between P1 and P2 causes a small amount of gas to flow through the overhead measuring tube. The separation ratio is constant.

Two resistance temperature detectors (RTD elements) transferring a constant amount of heat to the gas stream are mounted on the measuring tube. Under flow conditions, the gas molecules absorb and transport the heat away. This gives rise to a temperature difference between the two detector coils, which causes a change in resistance in the detector coils, whereby  $R_1 \neq R_2$ . The electronics converts the signal for indication. The temperature difference increases as the flow increases.

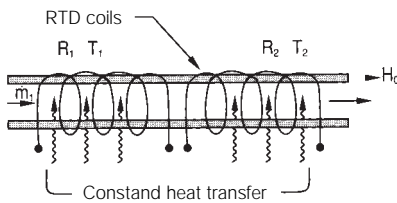

Measuring tube design

**Special advantages:**

- Direct mass flow measurement
- No pressure or temperature correction needed
- Large measuring range
- Negligible pressure loss
- May be fitted in any position
- High degree of repeatability
- Analog output 0 - 5 VDC, 4 - 20 mA, optional

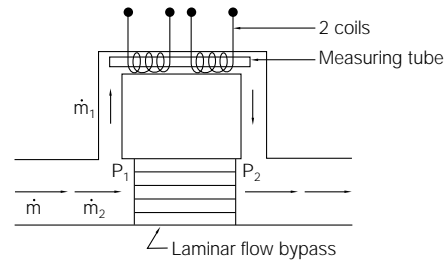

Flow diagram

**Order numbers**

Nylon version					Stainless steel version						
Meas. range Ncm <sup>3</sup> /min N <sub>2</sub>	Press. loss max. mbar	Connection int. thread	with digital indication	without dig. indication	Meas. range Ncm <sup>3</sup> /min N <sub>2</sub>	Press. loss max. mbar	Swagelok connection	Case size	with digital indication	without dig. indication	
0-10	1	1/4" NPT	MAS-1001	MAS-2001	0-10	6	1/4"	L	MAS-3001	MAS-4001	
0-20	1	1/4" NPT	MAS-1002	MAS-2002	0-20	6	1/4"	L	MAS-3002	MAS-4002	
0-50	1	1/4" NPT	MAS-1003	MAS-2003	0-50	6	1/4"	L	MAS-3003	MAS-4003	
0-100	1	1/4" NPT	MAS-1004	MAS-2004	0-100	6	1/4"	L	MAS-3004	MAS-4004	
0-200	1	1/4" NPT	MAS-1005	MAS-2005	0-200	6	1/4"	L	MAS-3005	MAS-4005	
0-500	1	1/4" NPT	MAS-1006	MAS-2006	0-500	6	1/4"	L	MAS-3006	MAS-4006	
<b>NI / min N<sub>2</sub></b>					<b>NI / min N<sub>2</sub></b>						
0-1	1	1/4" NPT	MAS-1007	MAS-2007	0-1	6	1/4"	L	MAS-3007	MAS-4007	
0-2	6	1/4" NPT	MAS-1008	MAS-2008	0-2	6	1/4"	L	MAS-3008	MAS-4008	
0-5	6	1/4" NPT	MAS-1009	MAS-2009	0-5	6	1/4"	L	MAS-3009	MAS-4009	
0-10	6	1/4" NPT	MAS-1010	MAS-2010	0-10	105	1/4"	L	MAS-3010	MAS-4010	
0-20	25	1/4" NPT	MAS-1011	MAS-2011	0-15	105	1/4"	L	MAS-3011	MAS-4011	
0-30	47	1/4" NPT	MAS-1012	MAS-2012	0-20	40	3/8"	M	MAS-3012	MAS-4012	
0-40	88	1/4" NPT	MAS-1013	MAS-2013	0-30	60	3/8"	M	MAS-3013	MAS-4013	
<b>Accessoires</b>					0-50	80	3/8"	M	MAS-3014	MAS-4014	
<b>MAS-5000</b>	Connector power supply 110 VAC, output 12 VDC				0-100	105	1/2"	M	MAS-3015	MAS-4015	
<b>MAS-5100</b>	Connector power supply 230 VAC, output 12 VDC				0-100	6	1/2"	H	MAS-3016	MAS-4016	
<b>Options</b> (append letter to order no.)					0-200	6	1/2"	H	MAS-3017	MAS-4017	
Option "A"	Analog output 4 - 20 mA				0-300	140	1/2"	H	MAS-3018	MAS-4018	
Option "C1"	Swagelok 1/4" (for nylon version)				0-400	140	1/2"	H	MAS-3019	MAS-4019	
Option "C2"	Swagelok 1/2" (for nylon version)				0-500	140	1/2"	H	MAS-3020	MAS-4020	
Option "V2"	Supply voltage 24 VDC										
Option "RD"	Separate digital indicator with 1,5 m lead										



**Technical details**

Field of application: suited only for **dry**, oil-free gases

Measuring accuracy:  $\pm 1,5\%$  f.s.  
(with calibrated performance characteristics, otherwise observe pressure and temperature coefficients)

Option:  $\pm 1\%$  v. f.s.  
(only to 0-100 Ncm<sup>3</sup>/min. measuring range with stainless steel case)

Standard calibration: 1013,25 mbar abs., 0°C  
option: to customer specification

Temperature coefficient: 0,15 % f.s. / °C

Pressure coefficient: 0,3 % f.s. / bar

Reproducibility:  $\pm 0,5\%$  f.s.

Response time (within 20 - 100 % of measuring range):  
2 s until 98 % of actual flow rate is indicated

Max. medium, and ambient temperature: 50°C

Max. working pressure: nylon: 10 bar  
stainless steel: 35 bar

Installation position: any

Gas density:  $1 \times 10^{-4}$  cm<sup>3</sup> / s He (nylon)  
 $1 \times 10^{-7}$  cm<sup>3</sup> / s He (stainl. steel case)

Wetted parts: 5 % either glass-fibre-reinforced nylon or stainless steel material no. 1.4401

Seals: FPM (Kaltrez, Neopren)

Supply voltage: 12- 15 VDC, 24 VDC optional

Output: linear 0 - 5 VDC (load min. 2000 Ω)  
option: 4 - 20 mA  
(burden max. 500 Ω)

**Connection diagram**

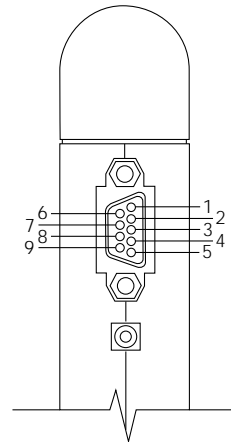

**PIN NO. FUNCTION**

- 1 No connection
- 2 Flow rate signal ground
- 3 0 bis 5 VDC flow rate signal
- 4 + mains supply (12 oder 24 VDC) <sup>1,2</sup>
- 5 External display signal
- 6 External display ground
- 7 Mains supply ground
- 8 Analog output 4 to 20 mA ground
- 9 Analog output 4 to 20 mA signal

<sup>1</sup> Devices powered with 24 VDC only, when the 24 V feature is built in, otherwise damage may be caused by overvoltage.

<sup>2</sup> Do not connect if the device is already supplied from the mains socket.

**Dimensions:**

**Case L (stainless steel)**

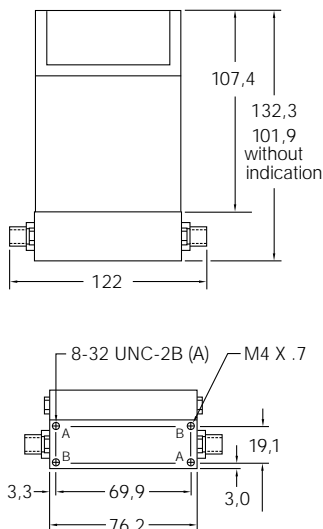

**Case M (stainless steel)**

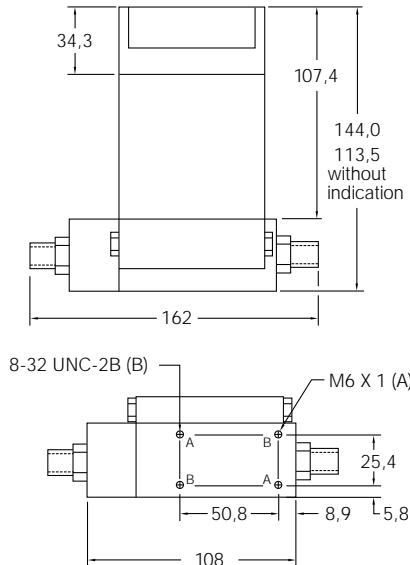

**Case H (stainless steel)**

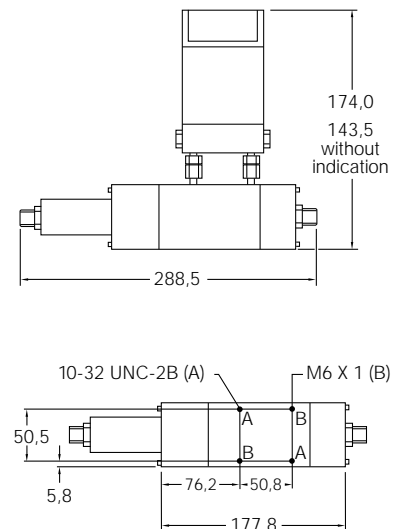



**Fields of application:**

In addition to accurately measuring the gas flow rate, it is also necessary to maintain a constant flow rate with varying inlet or outlet pressures in many processes.

This has been achieved heretofore by connecting a controlling system with electronic controller and control valve at the outlet side.

The new model MFC mass flow controller is a compact device composed of mass flow meter, controller and valve. The user is thus provided with a controlling system that maintains a constant flow rate over a wide range, independent of variations in pressure and temperature.

**Theory of operation:**

The medium flows through the MAS mass flow meter, which measures the actual flow rate.

The control electronics compares the measured value with the setpoint value. When deviations occur, the control electronics outputs an altered actuating signal to the built-in proportional valve which changes the passage opening, thereby maintaining a constant flow rate.

The desired flow rate (setpoint value) may be adjusted with a built-in potentiometer or via an external 0-5 VDC (4-20 mA optional) signal.

**Technical details:**

**Field of application:** suited only for dry, oil-free gases

**Measuring accuracy:** ± 1,5 % f.s.  
(with 10-100 % of flow rate range)

**Reproducibility:** ± 0,25 % f.s.

**Temperature coefficient:** 0,8 % f.s. / °C

**Pressure coefficient:** 0,07 % f.s. / bar

**Response time (within 20-100 % of measuring range):**  
1 s until 63 % of actual flow rate is indicated

**Max., medium, and ambient temperature:** 50°C

**Max. medium pressure:** nylon: 10 bar

**Gas density:** ambient:  $1 \times 10^{-4} \text{ cm}^3 / \text{s}$   
valve: not suitable as shut-off valve

**Material:** case: 10 % glass-fibre-reinforced nylon  
Swagelok: stainless steel  
seal: FPM

**Control range:** 2-100 % of measuring range  
(valve closes below 2 %)

**Supply voltage:** 24 VDC

**Output:** 0-5 VDC (load min. 2000 Ω)  
option: 4-20 mA (burden max. 1000 Ω)

**Control signal:** 0-5 VDC or 4-20 mA, adjustable

**Order numbers**

Nylon version				
Meas. range Ncm <sup>3</sup> /min N <sub>2</sub>	Min. required diff. pressure	Connection internal thread	with digital indication	without dig. indication
0-10	0,35 bar	1/4" NPT	MFC-5101	MFC-5201
0-20	0,35 bar	1/4" NPT	MFC-5102	MFC-5202
0-50	0,35 bar	1/4" NPT	MFC-5103	MFC-5203
0-100	0,35 bar	1/4" NPT	MFC-5104	MFC-5204
0-200	0,35 bar	1/4" NPT	MFC-5105	MFC-5205
0-500	0,35 bar	1/4" NPT	MFC-5106	MFC-5206
NI / min N <sub>2</sub>				
0-1	0,55 bar	1/4" NPT	MFC-5107	MFC-5207
0-2	0,55 bar	1/4" NPT	MFC-5108	MFC-5208
0-5	0,55 bar	1/4" NPT	MFC-5109	MFC-5209
0-10	1,00 bar	1/4" NPT	MFC-5110	MFC-5210
0-20	1,38 bar	1/4" NPT	MFC-5111	MFC-5211
0-30	1,38 bar	1/4" NPT	MFC-5112	MFC-5212
0-40	1,38 bar	1/4" NPT	MFC-5113	MFC-5213
0-50	1,38 bar	1/4" NPT	MFC-5114	MFC-5214

**Accessoires**

<b>MAS-8100</b>	Connector power supply, 230 VAC, output 24 VDC
Options (append letter to order no.)	
Option "C1"	Swagelok 1/8"
Option "C2"	Swagelok 1/4"



MFC dimensions (mm)

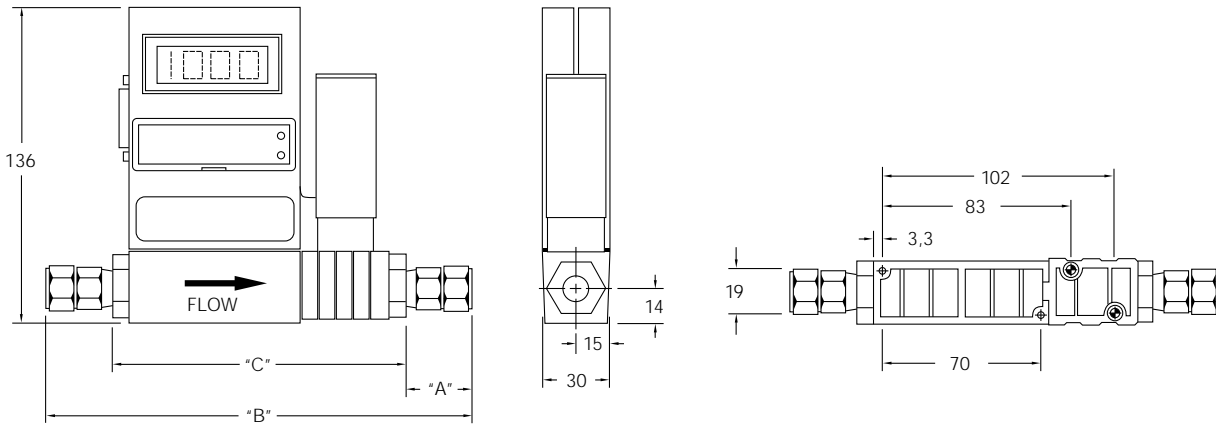

Connection	"A"	"B"	"C"
1/8" Swagelok	29	186	128
1/4" Swagelok	28	184	128
1/4" NPT	-	-	128