

Vortex Flow Meter

for liquids, gases, and vapours

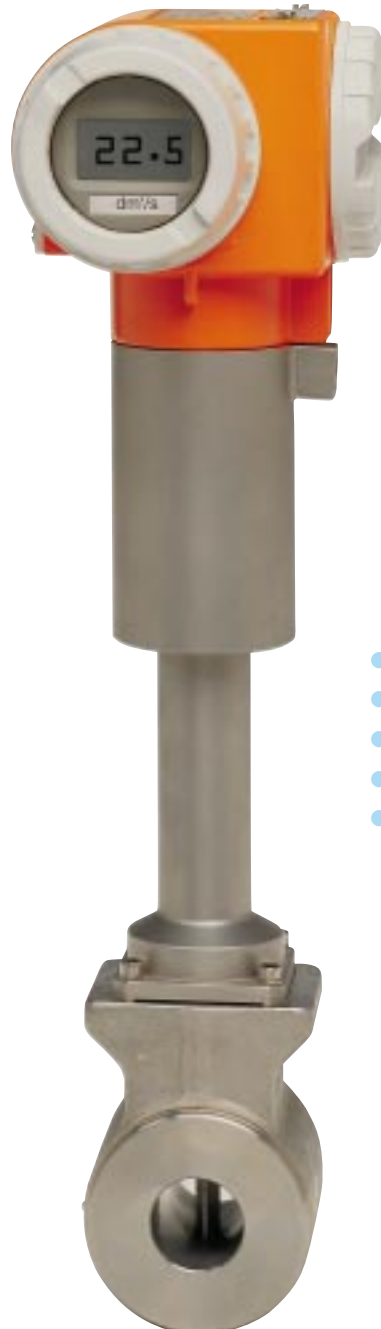

Flow
Pressure
Level
Temperature
measurement
monitoring
control



- Wide temperature range
- Stainless steel material
- Large turndown ratio
- Very high measuring accuracy
- Vibration-compensated

Model:
PWL

Description

The operation of the compact model PWL vortex flow meter is based on the vortex principle.

A Karman vortex street is formed downstream of a baffle, i.e. the fluid flow causes vortices to be formed at both sides. The vortex formation is proportional to the medium flow velocity.

Each vortex creates a small negative pressure, which is detected by a capacitive pressure pick-up, and converted to an electrical pulse. A downstream transmitter converts the pulse signal to a standard output signal.



The sensor has been designed to cause pipeline vibrations (<1g to 500 Hz) to be eliminated with a primary compensation. This means that no device adjustment or zero-point adjustment are needed.

Fields of application

- Liquids
- Gases
- Superheated steam
- Saturated steam

The PWL measures the volumetric rate of flow under service conditions. The flow rate may also be output as a mass or standard volume unit at constant operating pressure and temperature.

With varying process conditions, these values may be calculated by a downstream flow computer from the PWL values, and the additional pressure and temperature values to be measured.

Applications

- Mechanical engineering
- Chemical industry
- Petrochemical industry
- Heat supply
- Power engineering

Device design

The entire metering unit comprises the following:

Transducer

- The transducer for nominal sizes DN 15 to DN 300 is supplied with stainless steel flanges. The space-saving installation in DN 15 to DN 150 pipes is performed with transducers with wafer connection. The wafer is fitted in the pipeline with installation kit with an automatic centering (available as an optional extra).

Transmitter

- The transmitter is mounted on the transducer. All functions and parameters may be selected and changed with four buttons. The operator's menu and the local indicator are used to select the functions. The devices may be remotely operated with a hand-held terminal (available as an accessory) via HART protocol.

Technical details

Transducer

Temperature range: -200...400°C

Nominal size: DN 15 -150 (model PWL-W..)
DN 15 - 300 (model PWL-F..)

Nominal pressure: PN 10..40 (DIN 2501)

Immersion length: DVGW (model PWL-F..)

Wetted parts

Measuring tube: stainless steel 1.4571 (model PWL-W..)
st. steel 1.4552 (model PWL-F..to DN150)
st. steel 1.4571 (model PWL-F..> DN150)

Sensor: stainless steel 1.4435

Baffle: stainless steel 1.4435 (model PWL-W)
(exception DN 25, 1.4452)
st. steel 1.4552 (model PWL-F..to NW150)
st. steel 1.4435 (model PWL-F. > NW150)

Sensor seal: graphite, Kalrez optional, FPM, EPDM

Case support: stainless steel

Certificates: 3.1B (optional)

Transmitter

Case material: varnished aluminium die casting

Temperature: -40...80°C (ambient)

Supply: 12...30 VDC (without HART)
18,5...30 VDC (with HART)

Power input: < 1 Watt

Current output: 4...20 mA

Output: configurable open collector; as limit switch, fault output or pulse output
(I ≤ 10 mA; U_{max} = 30 V; R_i = 900 Ω)

Indicator: 4-position LCD

Cable entry fitting: PG 13,5

Resistance to vibration: 1g to 500 Hz, (all directions)

Protection type: IP 65 (DIN 60529)



Measuring accuracy

Liquids: < 0,75 % of meas value, if Re>20.000
< 0,75 % f.s., if Re 4000..20.000

Gas / steam: < 1 % of meas value, if Re>20.000
< 1 % f.s., if Re 4000..20.000

Full-scale value: liquids $V_{max} = 9 \text{ m/s}$
gas / steam $V_{max} = 75 \text{ m/s}$
DN 15 $V_{max} = 46 \text{ m/s}$

Repeatability: $\pm 0,2 \%$ of measured value

Current output: Temp. coefficient < 0,03 % f.s./°C

Measuring ranges

The measuring ranges for your particular service conditions may be calculated with a software package. Please contact us for advice on measuring ranges. The following parameters are needed for the calculations:

Liquids: nominal size, density, kinematic viscosity, flow rate

Vapour/gas: nominal size, pressure (relative or absolute), temperature, flow rate

Saturated steam: nominal size, pressure or temperature, flow rate

Order details (PWL-W with wafer)

Nominal size DIN 2501, PN10*	Air (Nm³/h)		Water (m³/h)		k factor (pulse/dm³)	Order number	Seal
	Qmin	Qmax	Qmin	Qmax	min/max		
DN 15	4,0	25,4	0,151	4,99	389,4...430,4	PWL-WS15A...	..A=graphite (-200...+400°C) ..B=FPM (-15...+175°C) ..C=Kalrez (-20...+240°C)
DN 25	10,6	150	0,38	18,0	57,1...63,1	PWL-WS25A...	
DN 40	27,7	394	0,998	47,3	13,8...15,2	PWL-WS40A...	
DN 50	44,3	630	1,6	75,6	6,8...7,5	PWL-WS50A...	
DN 80	102	1443	3,65	173	1,9...2,1	PWL-WS80A...	
DN 100	171	2432	6,16	292	0,87...0,97	PWL-WS1HA...	
DN 150	379	5381	13,6	646	0,266...0,294	PWL-WS1FA...	

*for pipes according to ANSI upon request

Order details (PWL-F with wafer)

Nominal size	Air (Nm³/h)		Water (m³/h)		k factor (pulse/dm³)	Order number	Nominal pressure	Seal
	Qmin	Qmax	Qmin	Qmax	min/max			
DN 15	3,94	24,9	0,15	4,92	389,4...430,4	PWL-FS15...	DN 15..DN 80 ..B..= PN 16 DN 15..DN 150 ..A..= PN 10 ..D..= PN 25 ..H..= A 150lbs SCH80 ..K..= A 300lbs SCH80 DN 15..DN 300 ..E..= PN 40 ..G..= A 150lbs SCH40 ..J..= A 300lbs SCH40	..A=graphite (-200...+400°C) ..B=FPM (-15...+175°C) ..C=Kalrez (-20...+240°C)
DN 25	8,8	125	0,317	15	76,2...84,2	PWL-FS25...		
DN 40	21,6	308	0,78	36,9	20,1...22,3	PWL-FS40...		
DN 50	36,1	513	1,3	61,3	9,0...10,0	PWL-FS50...		
DN 80	81	1151	2,92	138	2,7...3,0	PWL-FS80...		
DN 100	140	1994	5,5	239	1,16...1,29	PWL-FS1H...		
DN 150	319	4537	11,50	545	0,34...0,38	PWL-FS1F...		
DN 200	627	8916	27,6	1070	0,125...0,138	PWL-FS2H...		
DN 250	1001	14218	55,5	1707	0,0618...0,0683	PWL-FS2F...		
DN 300	1414	20094	93,3	2412	0,0336...0,0420	PWL-FS3H...		

Example of order: PWL - FS3H J C

Dimensions

PWL-W..(DN 15...DN 25)

DN	d	D	H	H1	kg
15	14	45	340	357	3,5
25	26,6	64	349	366	4

PWL-W..(DN 40...DN 150)

DN	d	D	H	H1	kg
40	43,1	89,3	316	333	4,5
50	54,5	99,3	325	338	5
80	82,5	135,3	342	359	6
100	107,1	155,3	357	374	9
150	159,3	210,3	387	404	17

PWL-F..(DN 15...DN 150)

DN	PN	d	dA	nx d2	g	x	L	H	H1	kg
15	40	13,9	17,3	4x14	45	17	200	343	360	5
25	40	24,3	28,5	4x14	68	19	200	347	364	8
40	40	38,1	43,1	4x18	88	21	200	355	372	11
50	40	49,2	54,5	4x18	102	24	200	335	352	13
80	40	73,7	82,5	8x18	138	30	200	346	363	20
100	16	97	107,1	8x18	158	33	250	360	377	27
150	16	146,3	159,3	8x22	212	38	300	386	403	55

PWL-F..(DN 200...DN 300)

DN	PN	L	D	x	d	H	H1	kg
200	10	300	340	30	205,1	400,5	417,5	39
	16	300	340	30	205,1	400,5	417,5	39
	25	300	360	36	205,1	400,5	417,5	47
	40	300	375	40	205,1	400,5	417,5	55
250	10	380	395	32	259	425,5	442,5	60
	16	380	405	36	259	425,5	442,5	60
	25	380	425	40	259	425,5	442,5	72
	40	380	450	48	259	425,5	442,5	93
300	10	450	445	32	307,9	451	468	85
	16	450	460	36	307,9	451	468	85
	25	450	485	44	307,9	451	468	106
	40	450	515	52	307,9	451	468	106

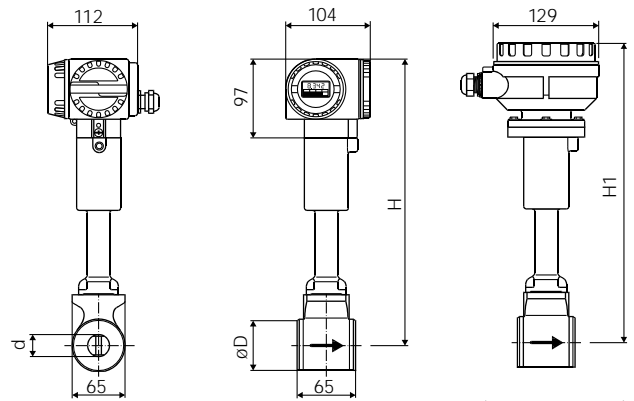

PWL-W..(DN 15...DN 25)

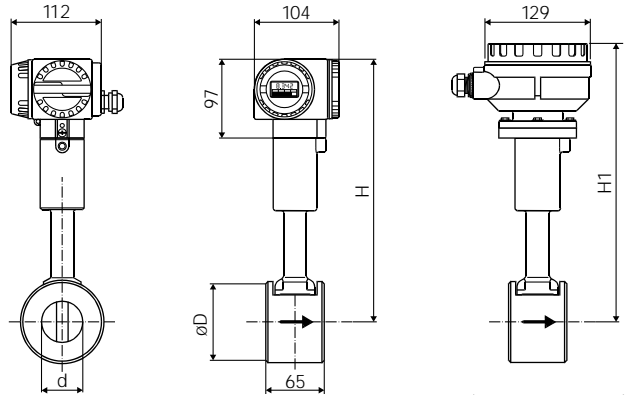

PWL-W..(DN 40...DN 150)

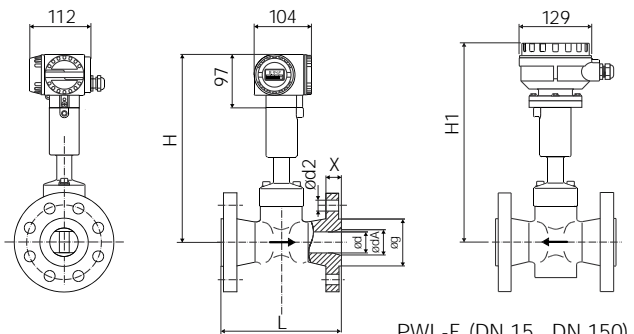

PWL-F..(DN 15...DN 150)

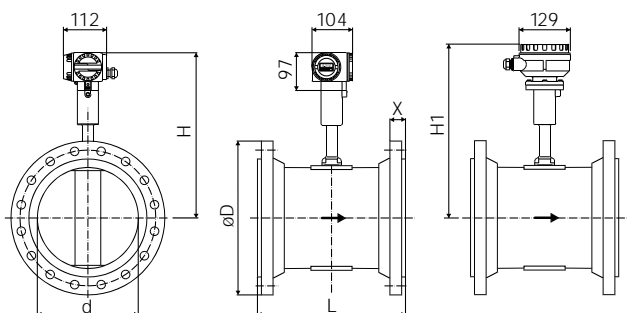

PWL-F..(DN 200...DN 300)