

Incremental Rotary Encoder

Hollow shaft model



- Max. speed: 12 000 rpm
- Hollow shaft: Ø 10/12 mm
- Output: RS422 or push-pull
- Electrical connection: 1 m cable
- Pulse count: 500 - 5000 pulses
- Max. pulse frequency: 200 kHz
- Supply: 5 - 30 V_{DC}
- Max. temperature: +75 °C
- Protection type: IP 66



KOBOLD offices exist in the following countries:

**ARGENTINA, AUSTRIA, BELGIUM, BRAZIL, CANADA,
CHINA, COLOMBIA, FRANCE, GREAT BRITAIN, NETHERLANDS,
POLAND, SWITZERLAND, USA, VENEZUELA**

KOBOLD Messring GmbH
Nordring 22-24
D-65719 Hofheim/Ts.
☎ (06192) 299-0
Fax (06192) 23398
E-mail: info.de@kobold.com
Internet: www.kobold.com

Model:
ZDI-BH



Description

KOBOLD rotary encoders are used to measure length, position, rotational speed and angle. They convert mechanical motion to electrical signals. Incremental rotary encoders output a frequency signal which can represent speed, length or position.

A rotatable disc, on which a grating is attached, is mounted between an LED and a receiver. The light emitted from the LED is modulated by the grating and hits the receiver, which outputs a sinusoidal signal that is proportional to the light received. The sinusoidal signal is processed by specially designed electronics. Standard control systems - including all KOBOLD counters - require digital, square-wave signals at the input. Thus the signal is conditioned in the rotary encoder and is outputted through different output circuits depending on the field of application.

Areas of application:

- Mounting technology
- Feeders and handling machines for electrical components
- Test equipment
- Medical engineering, for example stirring machines
- Inserting plant/letter opening machines
- Inspection platforms
- Labelling machines
- Pipe inspection machines (camera control)

Dimensions:

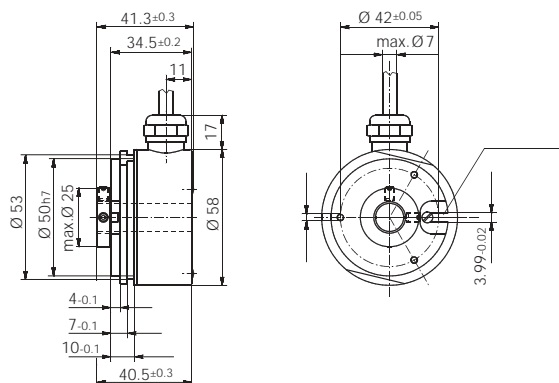

Technical Details:

Max. speed:	6000 rpm
Moment of inertia of rotor:	approximately 6 x 10 ⁻⁶ kgm ²
Initial torque:	< 0.05 Nm
Hollow shaft:	Ø 10 mm or Ø 12 mm stainless steel
Mechanical connection:	flange with through shaft
Impact resistance:	2000 m/s ² , 6 ms
Vibration resistance:	100 m/s ² , 10-2000 Hz
Operating temperature range:	-20 to +70 °C
Working temperature range:	-20 to +70 °C
Output circuit:	push-pull without inversion or RS422 with inversion (TTL-compatible) short-circuit-proof
Electrical connection:	1 m cable, radial
Pulse count:	10-5000 pulses
Max. pulse frequency:	300 kHz
Supply:	5-30 V _{DC} (push-pull) 5 V _{DC} ± 5% (RS422)
Current consumption:	max. 125 mA (push-pull) max. 90 mA (RS422)
Permissible load/channel:	max. ± 30 mA (push-pull) max. ± 20 mA (RS422)
Signal level high:	min. U _B -1.5 V (push-pull) min. 2.5 V (RS422)
Signal level low:	max. 2.0 V (push-pull) max. 0.5 V (RS422)
Rise time / fall time:	max. 1 µs (push-pull) max. 200 ns (RS422)
Pulses per revolution:	500, 512, 1000, 1024, 2048, 2500, 3600, 5000
Protection type:	IP 66
Weight:	approximately 0.4 kg

Order details (Example: **ZDI-BH 14 G 1 0500**)

Model	Description	Hollow shaft	Output circuit	Electrical connection	Pulse count (always use 4 digits)
ZDI-BH...	Incremental rotary encoder in hollow shaft model	14 = Ø 10 mm 15 = Ø 12 mm	G = push-pull without inversion R = RS422 with inversion	1 = 1 m cable, radial	0500, 0512, 1000, 1024, 2048, 2500, 3600, 5000