



中国授权代理商 联系方式  
Free Tel:4000240008  
Tel:010-82951585 82946733  
Fax:010-58859230  
E-mail:bjsdsf@126.com

# Y-1 交流磁轭

## Y-1 AC MAGNETIC YOKE

操作使用手册 (中英文版)  
OPERATING MANUAL(CN/EN)

<b>入门指南</b>	
简介 .....	1
<b>防范措施</b>	
安全指导 .....	2
<b>技术说明</b>	
技术参数 .....	3
工作电源要求 .....	3
<b>操作指南</b>	
工作原理 .....	4
操作说明 .....	4
磁痕解读 .....	5
评判 .....	5
退磁 .....	5
<b>推荐化学品和附件</b>	
产品列表 .....	6
<b>维护</b>	
产品维护保养 .....	6
<b>检修</b>	
故障排除 .....	7
<b>零件识别</b>	
零件列表和图示一 .....	8
零件列表和图示二 .....	9
<b>质保期</b>	
质保范围 .....	10
<b>技术支持</b>	
联系我们 .....	10

## 入门指南

感谢您购买美国磁通Y-1交流磁轭，美国磁通为无损检测行业提供高性能，创新型的附件产品。Y-1交流磁轭是新一代的轻量级，符合人体工程学的手提式电磁轭产品，可有效减轻一线操作者在狭小区域长时间测试工作，从而引起的腰部和手腕的疲劳。

Y-1磁轭配有活动关节式的磁脚，可灵活方便的产生磁场，以检测工件表面的缺陷。磁化组件由磁芯和高效节能的磁化线圈组成，这些组件被安装在带电源线 and 操作开关的绝缘外壳中，每个磁脚都直接连接磁芯。带有两个活动关节的磁脚能和任何形状的工件良好接触。115伏/230伏电压的磁轭配有一条10英尺长的电缆和标准三头接地式插头。

### 防范措施

每次使用前必须进行检查。检查外壳是否破裂，开缝，螺丝是否松开，需小心的拧紧螺丝。检查电线是否损坏。如发现以上损伤，强烈建议将此磁轭送到美国磁通认证的维修中心进行维修。如必须现场维修，请参考本手册中维修部分的装配指导。

**警告！** 在油浴或水浴条件下小心使用。避免将任何液体直接喷洒在磁轭上或将磁轭浸入其中，这些行为将会导致漏电和人身伤害。

**着装恰当：** 在室外检测时可以穿着橡皮手套和橡胶鞋。请勿在操作时光脚或穿着开口拖鞋。使用符合安全标准的护目镜或者带侧挡板的防护眼镜，或在需要时佩戴防护面罩。

**请勿过度使用磁轭电源线：** 不要提着电源线运送磁轭或者拉扯电源线来拔出插头。使其远离高温，油污和锐利的边缘。不要拉着电源线来取回磁轭。不要将其悬挂磁轭。磁轭的外壳前端有预设孔，可系带或挂钩。

**延长电源线：** 只能使用含地线的延长电线，否则会导致安全隐患。确保在良好的环境下使用延长电线。如需使用延长电线，请选择负载电流规格与磁轭相匹配的电线。

使用规格太小的电线容易导致因电压下降而损失功率。请参考下面表格，根据电线长度和电流安培等级来选择合适的电线规格。如果不能确定，请选择下一级更大的规格。电线的规格号越小表示电线的负载越高。

电线规格			
0-25 英尺	26-50 英尺	51-100 英尺	101-150 英尺
0 - 7.6 米	7.6 - 15.2 米	15.2 - 30.4 米	30.4 - 45.7 米
安培等级			
超出		不超出	
美国线规			
0 - 6	18	16	16
6 - 10	18	16	14
10 - 12	16	16	14
12 - 16	14	12	不推荐更小规格

Y-1磁轭装配了高质量的耐油污耐磨损的电源线和插头，然而，使用较长和高规格的延长电线仍会增加磁轭本身电源线所受拉力，从而导致过早失效和损坏。为避免此类风险的发生，请注意对延长电线加以支撑，以减小对磁轭电源线的附加拉力。

**警告！** 在室外使用延长电线时，为了减少触电的风险，请仅连接一根室外用的延长线，例如以下型号的延长电线：**SW-A, SOW-A, STW-A, STOW-A, SJW-A, SJOW-A, SJTW-A, or SJTOW-A.**

**接地故障断路器 (GFCI)：** 在使用磁轭时，可在电路里或磁轭电源接口处连接GFCI提供保护。使用内置有GFCI的插座也可确保相同的保护作用。

请勿在潮湿和湿润的环境下使用磁轭。请勿在雨中使用磁轭。

### 规格参数

一般规格	Y-1 交流磁轭
重量	4.56 磅 (2.07公斤)
磁脚间距	最大11英寸 (280毫米)
电缆线长	10 英尺 (约3米)

### 工作电源要求

件号	电源要求
623502	115 V, 60 Hz, 3.7 A (最大)
625749	115 V, 50 Hz, 6.5 A (最大)
623503	230 V, 50/60 Hz, 1.6 A (最大)
625750	
645000	
640024	



## 工作原理

将磁轭连接到合适的交流电源上，按下激磁开关，在两个磁脚间产生一定强度的磁场。用来检测铁磁性材料时，施加磁场后表面不连续和缺陷就会产生漏磁场，施加磁粉后，这些缺陷会吸附磁粉在材料表面指出缺陷。

取决于磁轭与被测表面的接触程度，在磁轭的磁脚（即磁极）处会产生不同的漏磁场，同样会吸附磁粉形成可被观察到积聚现象，从而掩盖磁极附近区域的磁痕显示。在粗糙表面上，由于磁轭的两个磁脚与检测区域接触不良，此“盲区”尺寸会变大。因此，最佳的检测区域位于两磁脚的中间，磁场规律排列的区域。

磁轭产生的有效磁场可以用穿过两磁极间的大量磁力线（磁通）来描述。用磁轭来检查一块铁板，磁通量是闭合的，磁极之间的表面区域成为磁路的一部分。如有一个表面不连续会截断磁力线，则在不连续的两侧形成正负磁极，漏磁场存在于不连续的上方。磁粉会被这个漏磁场所吸附，标示出这个不连续的位置。

使用交流电源的磁轭并不能有效的检测出材料较深处（次表面）的不连续现象。如需要检测次表面的缺陷，请联系美国磁通（发送邮件至infochina@magnaflux.com，或拨打电话：4000-6869-80）咨询详情。

## 操作说明

将磁轭的磁脚放置和紧靠在被测区域（接触越完全，得到的结果越好），根据可能的缺陷位置调节磁脚的角度和方向，按下激磁开关。举例说明，当检测焊缝上的纵向裂纹，放置磁轭时，应使两磁脚横跨放在焊缝的两边。如果可能的缺陷方向不确定，应在该区域检测两次，在第二次检测时，需把磁轭旋转90度。

在磁轭通电后，使用磁粉喷球，将磁粉喷洒在两磁脚之间的区域，可选用美国磁通的干磁粉（#1 灰色，#2 黄色，#3A 黑色 或 #8A 红色）。喷粉时，电流开关应保持在“on”位置（连续法）。不断的重复该检测步骤直到所有待测区域都被检测完。

非荧光磁粉或者荧光磁粉的选择应使其与被测工件表面的反差利于观察。可使用美国磁通WCP-2白色反差增强剂，WCP-2可在待测工件的表面形成一层白色的快干型薄膜，用来提高磁痕显示的对比度。

## 磁痕解读

1. 必须对磁痕进行正确的解读和判定，磁痕的尺寸，形状，外观，位置和检测方向，以及了解被测工件的工艺过程都可帮助检测员做出正确的判断。

## 评判

1. 评判是检测过程中最重要的部分，判定工件的已知不连续是否可以被接受，或需要维修，或必须报废。这取决于不连续是否影响到了工件的使用可靠性。许多有磁痕显示的工件是可以接受的。

## 退磁

可用以下两种方法对工件进行退磁：

1. 如果工件处于一个交变磁场中，当电流逐渐减小为0，即可达到退磁的效果，例如，使用可变电压的电源或者使工件缓慢离开磁场。
2. 如必须对工件退磁，我们Y-1磁轭也可获得满意的退磁水平。可使用第二种退磁方法，将工件置于两磁脚之间，一边激磁一边缓慢的提起磁轭到离开工件18英寸的距离，然后松开激磁开关。

## 推荐化学品和附件

产品列表

### 推荐化学品和附件

件号 #	描述
干法非荧光磁粉	
01-1716-20C	#1 灰色干法磁粉 - 5千克/桶
01-1716-30C	#1 灰色干法磁粉, 20千克/桶
01-1732-69	#2 黄色干法磁粉, 10磅/桶
01-1732-87	#2 黄色干法磁粉, 45磅/桶
01-1748-87	#3A 黑色干法磁粉, 45磅/桶
01-1780-20C	#8A 红色干法磁粉, 5千克/桶
01-1780-30C	#8A 红色干法磁粉, 20千克/桶
湿法荧光磁粉	
01-1725-38	14A Aqua-Glo预混合荧光磁粉水磁悬液, 16盎司喷罐, 12罐/箱
01-0145-78	14AM预混合荧光磁粉油磁悬液, 16盎司喷罐, 12罐/箱
01-0145-50C	14AM预混合荧光磁粉油磁悬液, 20升/桶
其他附件	
623745	磁轭灯
624115	交流磁轭提升力试块, 10磅
501232	磁粉喷球
008M004	磁场指示器

## 维护

产品维护保养

### 维护

**清洁:** 仅使用中性肥皂和湿润的布清洁磁轭。不要使任何液体进入磁轭内部。也不要将磁轭的任何部分浸入液体。

**重要:** 为了确保产品的安全性和可靠性, 请通过美国磁通授权的服务中心来维修和维护产品, 使用原装替换零件。

**警告!** 产品的外壳被打开后, 在使用前必须使用推荐的密封剂重新密封, 否则将因液体的渗入导致漏电。

**重新装配说明:** 在必要的维修和检测后, 重新装配磁轭, 需确保电线安放在原来的路径位置。按图片D-2 (第九页) 的位置安装新的螺丝和使用新的密封剂。正确的密封是至关重要的。美国磁通推荐在售后服务中使用 Dap 50 Year 透明硅酮密封剂来重新装配磁轭。

## 检修

故障排除

### 检修

故障	可能原因	可能解决方案
无法激磁	电源线未接好	将电源线接入可靠接地的插座或者延长电线
	电源线损坏	请联系美国磁通售后服务中心
	开关损坏	请联系美国磁通售后服务中心
	电源短路或断路	重新连接电源
	延长电线损坏	更换延长电线
	GFI 跳闸	重新设置GFI
磁轭无法提起10磅提升力试块	磁脚尾端老化或磨损	将磁脚锉至原来平整的状态或更换新的磁脚
	磁脚尾端未良好接触试块	调整磁脚位置使其充分接触试块
	延长电线的规格不能支持恰当的电流通过	请参考安全防范部分的电线规格选择表
	试块不合格	推荐使用美国磁通的10磅交流磁轭提升力试块, 部件号: 624115
磁脚不能调整转动	磁脚的螺丝太紧	使用匹配的扳手微微松开螺丝
	磁脚关节生锈	松开磁脚的螺丝, 使用金属刷清除锈迹; 重新装配并使用锈迹清除剂和防锈剂LPS-1或LPS-2; 重新拧紧螺丝, 依然保证磁脚可自由转动。

# 零件识别

零件列表和图示一



图 D-1

编号 #	数量	描述
1	1	外壳
2	1	核心线圈, 230V
3	1	电源线, 230V
4	1	切换器
5	1	激磁开关
6	1	O型密封圈
7	1	绝缘体
10	2	磁脚垫片

# 零件识别

零件列表和图示二

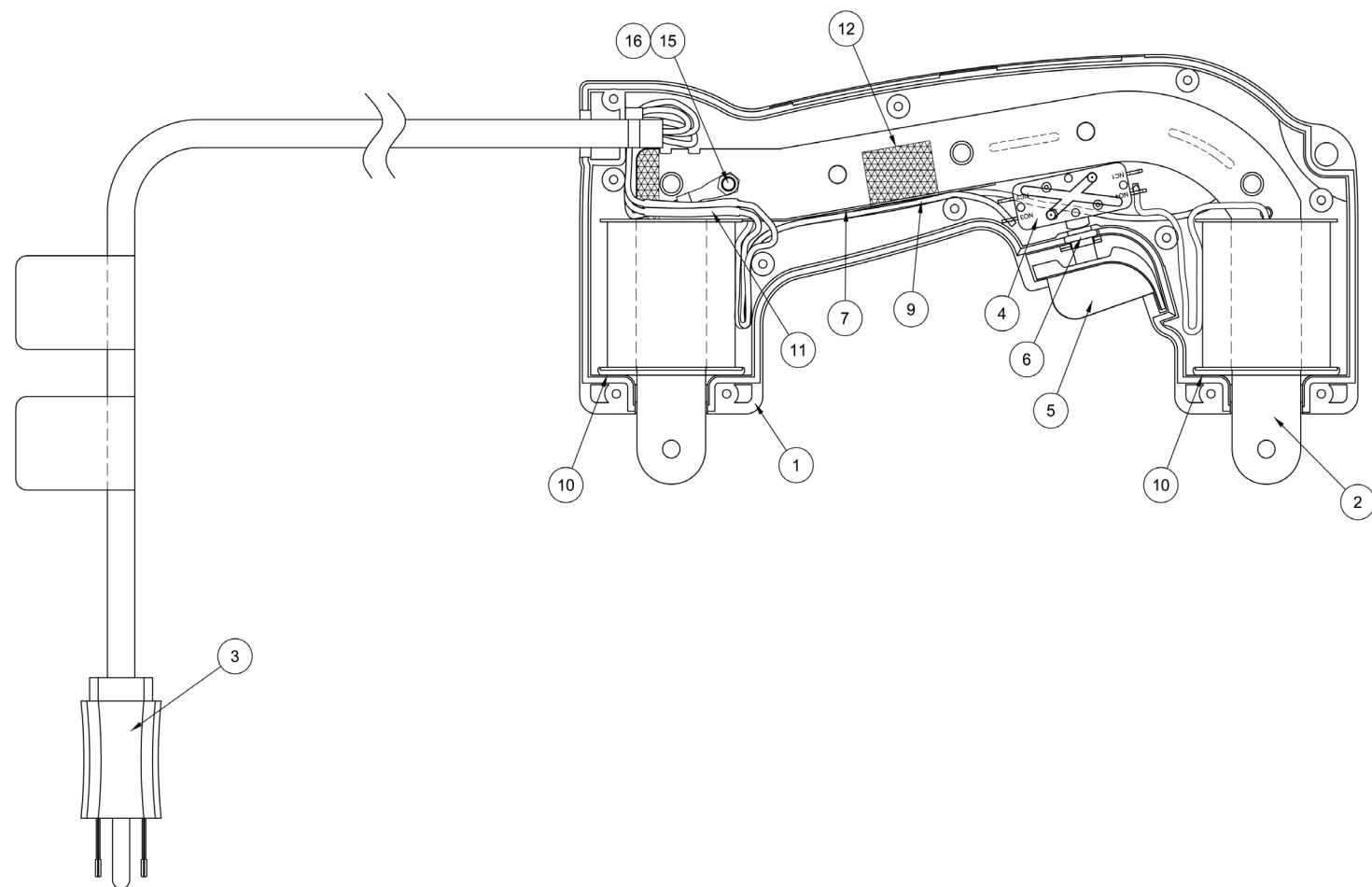
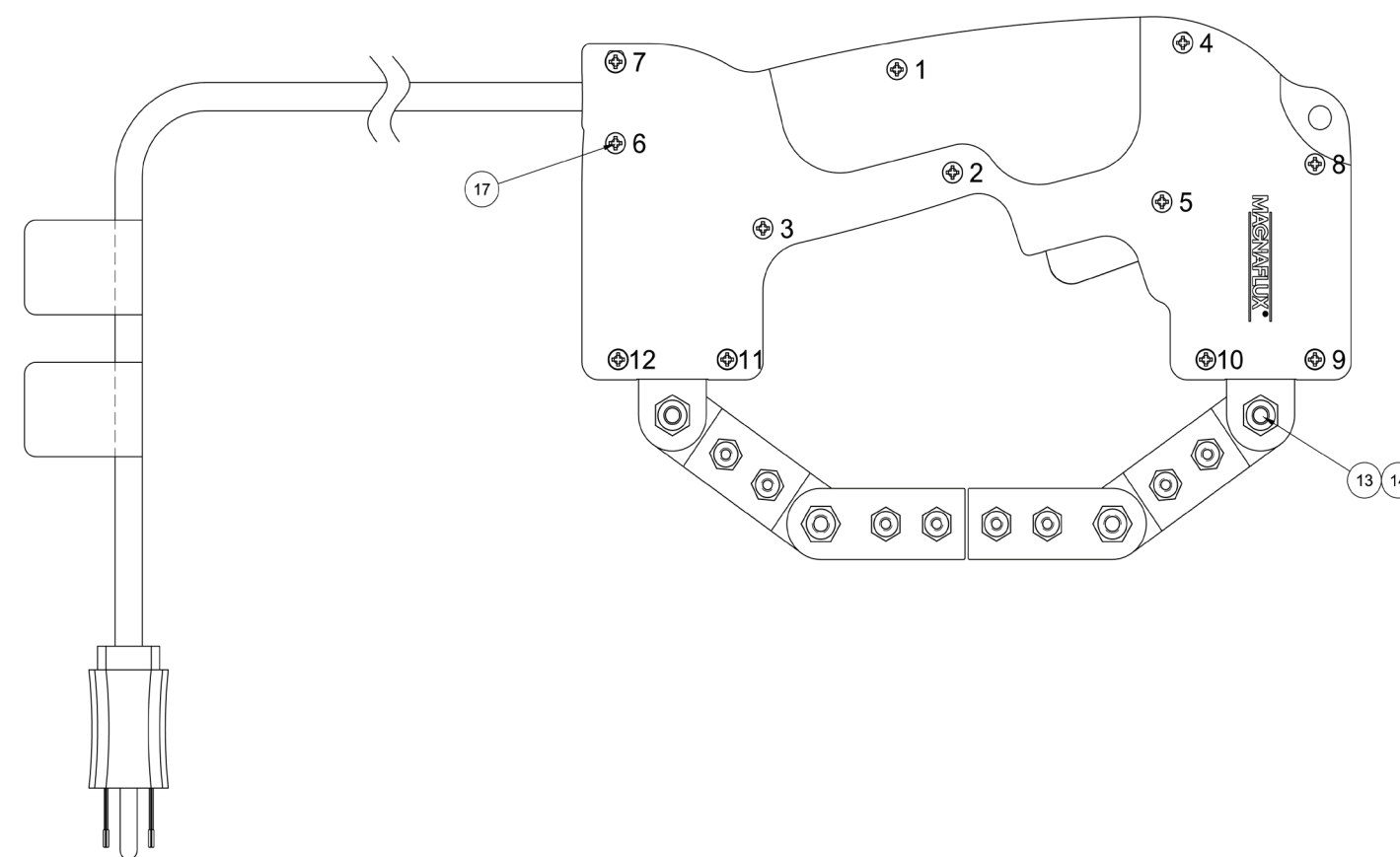

图D-2

编号 #	数量	描述
13	-	PHMS螺丝, 10-32 x 1.125 英寸
14	-	10-32尼龙螺母
17	-	#4-20 x .3125 三角螺丝

## 质保期

美国磁通质保范围

## 质保期

请联系美国磁通咨询质保条款。

## 技术支持

联系我们

## 技术支持

如果您有任何关于Y-1交流磁轭的购买，操作和售后的疑问，请联系美国磁通：

**中国授权代理商** 联系方式

Free Tel:4000240008

Tel:010-82951585 82946733

Fax:010-58859230

E-mail:[bjdsf@126.com](mailto:bjdsf@126.com)

也可直接联系您当地的分销商和美国磁通授权的服务中心。请在官网上查找相应的分销商和美国磁通授权的服务中心的联系方式。

**GETTING STARTED**

Intro .....1

**PRECAUTIONS**

Safety Guidelines .....2

**SPECIFICATIONS**

Technical Data .....3

Electrical Requirements .....3

**OPERATION**

Principles of Operation .....4

Operation.....4

Interpretation .....5

Evaluation.....5

Demagnetization .....5

**ACCESSORIES**

Product Offering .....6

**MAINTENANCE**

Preventative Maintenance and Care .....6

**TROUBLESHOOTING**

Problem Solving .....7

**IDENTIFYING PARTS**

Drawing 1 and Parts List .....8

Drawing 2 and Parts List .....9

**WARRANTY**

Warranty Coverage .....10

**SUPPORT**

Contact Us.....10

**GETTING STARTED**

Congratulations on your purchase of the Y-1 AC Magnetic Yoke. Magnaflux® provides the NDT industry with top-performing, innovative accessories. The Magnavis® Y-1 AC Magnetic Particle Inspection Yoke is the new generation of light weight, ergonomically designed yokes that improve job performance and productivity by reducing operator arm and wrist fatigue when testing in tight, confined and overhead areas.

The Y-1 Yoke is an articulated leg magnetic yoke, which provides a portable means of creating magnetic fields for the detection of surface indications. The unit consists of a core with energy efficient magnetizing coils. These components are housed in an isolated shell, which also anchors the power cable and the operating switch. Each leg is connected to the core, and has two moveable joints permitting a contouring fit to various part geometries. The 115 volt yoke and 230 volt yoke are equipped with a ten-foot line cable having a standard three prong-grounding plug.





## PRECAUTIONS

### SAFETY GUIDELINES

## PRECAUTIONS

Inspect before each use. Inspect housing for cracks, open seams and/or loose screws. Tighten screws carefully if necessary. Inspect cord for damage. If damage to the cord or housing is present, it is strongly recommended the yoke be sent to an authorized Magnaflux service center for repair. If field repair is absolutely necessary, see maintenance portion of this manual for reassembly instructions.

**WARNING!** Use caution when using oil or water bath. Avoid spraying the yoke directly or immersing the yoke in liquid of any kind. Failure to do so can result in electrical shock and personal injury.

**DRESS PROPERLY:** Rubber gloves and substantial rubber footwear are recommended when working outdoors. Do not operate when barefoot or wearing open sandals. Use safety goggles or safety glasses with side shields complying with applicable safety standards and, when needed, a face shield.

**DON'T ABUSE CORD:** Never carry yoke by cord or yank it to disconnect from receptacle. Keep cord from heat, oil, and sharp edges. Never retrieve yoke by pulling on cord. Do not suspend the yoke by the cord. A suspension loop is provided on the housing above the front coil that will accommodate a belt clip or hanger loop.

**EXTENSION CORDS:** Use grounded extension cords only! Failure to do so will cause an unsafe condition. Make sure your extension cord is in good condition. When using an extension cord, be sure to use one heavy enough to carry the current the yoke will draw.

An undersized extension cord will cause a drop in line voltage resulting in loss of power. The table below shows the correct size to use depending on cord length and nameplate ampere rating. If in doubt, use the next heavier gauge. The smaller the gauge number, the heavier the cord.

Minimum Gauge for Cord Sets Total Length of Cord in Feet				
0-25 ft	26-50 ft	51-100 ft	101-150 ft	
0 - 7.6 m	7.6 - 15.2 m	15.2 - 30.4 m	30.4 - 45.7 m	
<b>Ampere Rating</b>				
More Than		Not More Than		
<b>American Wire Gauge</b>				
0 - 6	18	16	16	14
6 - 10	18	16	14	12
10 - 12	16	16	14	12
12 - 16	14	12	Not Recommended	

The Y-1 yoke is equipped with a high quality oil and abrasion resistant cord and plug however, use of long and heavy gauge extension cords will add stress to the yoke cord and will lead to damage and premature failure. To reduce the risk of these conditions, always support the extension cords to reduce added stress on the yoke cord.

## PRECAUTIONS

### SAFETY GUIDELINES

## PRECAUTIONS CONTINUED

**WARNING: OUTDOOR USE EXTENSION CORDS** To reduce the risk of electric shock, use only with an extension cord intended for outdoor use, such as an extension cord of type **SW-A, SOW-A, STW-A, STOW-A, SJW-A, SJOW-A, SJTW-A, or SJTOW-A.**

**GROUND FAULT CIRCUIT INTERRUPTER (GFCI):** GFCI protection should be provided on the circuits or outlets to be used for the yoke. Receptacles are available having built in GFCI protection and may be used for this measure of safety.

**Don't use yoke in damp or wet locations. Don't use yoke in the rain.**

## SPECIFICATIONS

### TECHNICAL DATA

## SPECIFICATIONS

GENERAL SPECIFICATIONS	Y-1 AC MAGNETIC YOKE
Weight	4.56 lbs
Leg Span	0" - 11" (0-30cm)
Cord Length	10 Feet

## ELECTRIAL REQUIREMENTS

PART NUMBER	ELECTRICAL REQUIREMENTS
623502	115 VAC, 60 Hz, 3.7 amps (max draw)
625749	115 VAC, 50 Hz, 6.5 amps (max draw)
623503	230 VAC, 50/60 Hz, 1.6 amps (max draw)
625750	
645000	
640024	

## PRINCIPLE OF OPERATION

With the yoke connected to a suitable source of alternating current, depressing the switch creates the magnetic field between the legs of the unit. When applied to ferromagnetic materials, indications or similar surface discontinuities occur across the magnetic field causing leakage fields. These leakage fields create indications when magnetic particles are applied on the surface.

Depending upon the degree of contact with the test surface, magnetic yokes have a characteristic leakage field around each leg that becomes visible in the presence of magnetic particles and that tends to obscure indications in the immediate vicinity. This area will increase in size on rough surfaces, which results in poor contact between the legs of the yoke and the area tested. For this reason, the best indications will be those mid way between the legs where the magnetic field forms a regular pattern.

The effective magnetic field of a yoke is best described as a multiplicity of invisible lines of force extending across the gap between the legs. When the yoke is applied to a steel plate, the magnetic flux is closed and the magnetic field enters the plate making its passage between the legs of the yoke at and very near the surface. A surface indication across this field cuts the magnetic circuit; the two sides of the indication become opposite poles of a magnet, and a leakage field will occur in the air above the magnetic particles. The magnetic particles are attracted by this leakage field and mark its location.

The magnetic field generated by an AC yoke does not penetrate deep enough to reliably detect subsurface discontinuities. If subsurface discontinuities detection is required, contact Magnaflux at (infochina@magnaflux.com or call 4000-6869-80) for recommendations.

## OPERATION

The legs of the yoke are positioned and placed against a part or area to be tested (the more intimate the contact the better the results). For best results, position the legs of the yoke at right angles to the direction of suspected indications and depress the switch. As an example, when testing for longitudinal surface indications in a weld, the yoke legs should be positioned, so that the yoke legs straddle the weld. If the direction of a possible defect is unknown, two inspections should be done in the area, turning the yoke approximately 90 degrees for the second inspection.

Using the powder spray bulb, apply the area between the legs of the yoke lightly with Magnaflux dry powder (#1 Gray, #2 Yellow, #3A Black or #8A Red), while energizing the yoke. Current should remain "on" (continuous method) during inspection time. This process is then repeated until the entire area of the part is inspected.

The selection of powder color or the use of fluorescent powders is dictated by the desire to create a contrast between the part being inspected and the powder. The use of Magnaflux WCP-2, White Contrast Paint offers excellent opportunities to assist inspections. WCP-2 creates a thin, fast drying and white contrast area on the part you are checking for indications.



## INTERPRETATION

1. After an indication has formed, it must be correctly "interpreted" or "identified". Size, shape, appearance, location and direction of the indication, as well as knowledge of the history of the part all assist the experienced inspector in correct interpretation.

## EVALUATION

1. The most important part of the inspection is the decision as to whether a part with a known discontinuity is acceptable, can be repaired, or must be rejected. This depends on how the discontinuity affects the serviceability of the part. Many parts with indications are acceptable.

## DEMAGNETIZATION

Demagnetization may be done in two principle ways.

1. Either the part is held within an alternating magnetic field while exciting current is gradually reduced to zero value, such as when using a variable voltage power supply, or the part is slowly withdrawn from the field which in effect accomplishes the same result.
2. In cases where demagnetization is necessary, our Y-1 yoke may be used to obtain a satisfactory level of demagnetization. As applied to yoke operation, the second method described above is approximated by placing the part across the poles while the current is flowing and slowly withdrawing it from the part to a distance of at least eighteen inches before turning off the magnetizing current.

## ACCESSORIES

PRODUCT OFFERING

### ACCESSORIES

PART #	DESCRIPTION
<b>VISIBLE DRY METHOD POWDERS</b>	
01-1716-20C	#1 Gray - 5kg Pail
01-1716-30C	#1 Gray - 20kg Pail
01-1732-69	#2 Yellow - 10lb Container
01-1732-87	#2 Yellow - 45lb Container
01-1748-87	#3A Black - 45lb Container
01-1780-20C	#8A Red - 5kg Pail
01-1780-30C	#8A Red - 20kg Pail
<b>FLUORESCENT WET METHOD PARTICLES</b>	
01-1725-38	14A Aqua-Glo - Case of 12 Aerosol Cans
01-0145-78	14AM Prepared Bath Oil - Case of 12 Aerosol Cans
01-0145-50C	14AM Prepared Bath Oil - 20L Pail
<b>OTHER ACCESSORIES</b>	
623745	Yoke Light Kit
624115	10 Pound Test Weight
501232	Powder Spray Bulb
008M004	Magnetic Flux Indicators

## MAINTENANCE

PRODUCT CARE

### MAINTENANCE

**CLEANING:** Only use mild soap and a damp cloth to clean the yoke. Never let any liquid get inside the housing. Never immerse any part of the yoke into a liquid.

**IMPORTANT:** To assure product SAFETY and RELIABILITY, repairs and maintenance should be performed by Authorized Magnaflux Service Centers, using identical replacement parts.

**WARNING!** If the housing is opened for any reason, it must be resealed with the recommended sealant before reuse. Failure to do so may result in fluid intrusion and potentially cause electrical shock.

**REASSEMBLY INSTRUCTIONS:** After necessary repairs and tests have been performed, reassemble the yoke, ensuring that the wires are routed in the original position. Apply new sealant and tighten screws in the numbered order shown on Figure D-2 (Page 9) of this manual. The correct sealant is a crucial component in this process. Magnaflux recommends Dap 50 Year Clear Silicone sealant for post service reassembly.

## TROUBLESHOOTING

PROBLEM SOLVING

### TROUBLESHOOTING

PROBLEM	POSSIBLE CAUSE	POSSIBLE SOLUTION
Yoke will not energize	Cord Unplugged	Plug cord into a fully grounded outlet or extension cord
	Damaged or defective cord	Contact Authorized Magnaflux Service Center to repair or replace cord
	Damaged or defective switch	Contact Authorized Magnaflux Service Center to repair or replace switch
	Blown fuse or breaker in power supply	Reset breaker or replace fuse
	Defective extension cord	Replace extension cord
	Tripped GFI	Reset GFI button
Yoke will not lift 10lb test weight	Foot sections of legs are worn or rounded	File or grind feet back to original flat condition or replace
	Foot sections turned and not making full contact	Adjust feet to make flat full contact with weight
	Extension cord too light to supply adequate current	See table in precautions section for proper size
	Improper test weight	Magnaflux part No. 624115 test weight should be used
Legs still or do not move	Leg bolts too tight	Loosen slightly with properly sized wrench
	Legs rusted at joints	Remove bolts and legs and clean with wire brush to remove rust. Reassemble using a rust remover/preventer such as LPS-1 or LPS-2. Retighten bolts until legs are tight but still move freely.

**IDENTIFYING PARTS**

DRAWING 1 & PARTS LIST

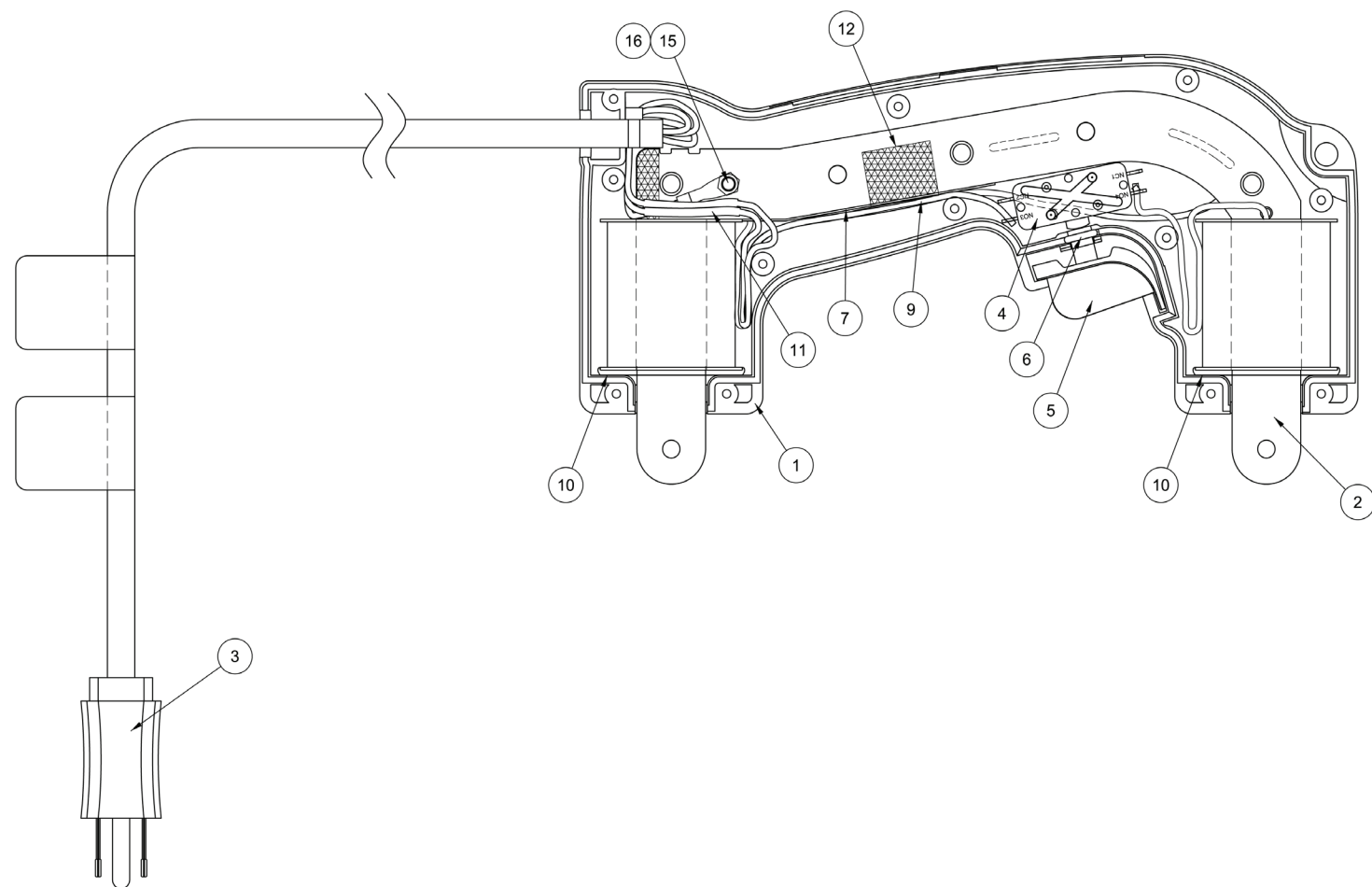
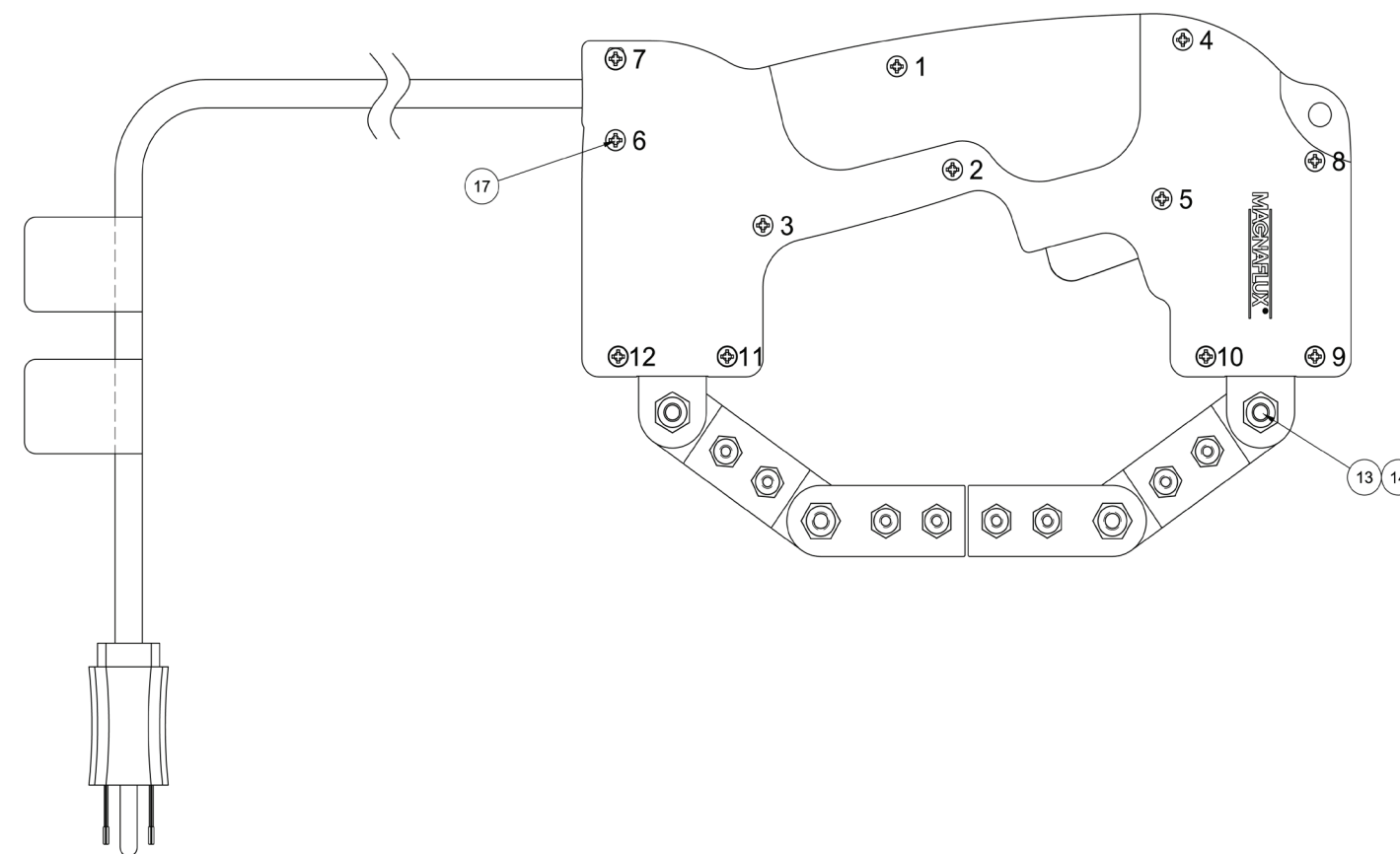

**Figure D-1**

INDEX #	QTY	DESCRIPTION
1	1	Housing
2	1	Core/Coil Assembly, 230V
3	1	Cord Assembly, 230V
4	1	Switch
5	1	Switch Button
6	1	O-Ring
7	1	Insulator
10	2	Leg Gasket

**IDENTIFYING PARTS**

DRAWING 2 & PARTS LIST



**Figure D-2**

INDEX #	QTY	DESCRIPTION
13	-	PHMS, 10-32 x 1.125 Inches
14	-	Nut, 10-32 Nyloc
17	-	Screw, #4-20 x .3125 Tri-Lobular



## WARRANTY

MX COVERAGE

## WARRANTY

Please contact Magnaflux to acquire the Warranty Statement.

## SUPPORT

CONTACT US

## SUPPORT

If you have a question about the purchase, operation or servicing of the Y-1 AC Magnetic Yoke, please contact Magnaflux® at:

Phone: 4000-6869-80  
Fax: 021-5428 2675  
URL: [www.magnaflux.cn](http://www.magnaflux.cn)  
E-mail: [infochina@magnaflux.com](mailto:infochina@magnaflux.com)

You may also contact your local Distributor or Magnaflux® Authorized Service Center directly. Contact information for our local Distributors and Authorized Service Centers can be found on our website.





