



GAST RAA 摇摆活塞式压缩机 真空泵

为什么选择我?

我们是摇摆活塞式压缩机与真空泵,具有显著的应用环境优势,各种电机选择,理想的实验室使用,我们结构紧密,活塞与轴承组件一体,不会因打滑,松动,错位造成故障,有气缸单元选择.



优点

- 无油式29" HG,2.7CFM,100PSI
- 低噪音,低维护成本
- 结构坚固,长寿命
- 包含电容

应用

气体压缩,饮料分配,液体分析,汽车维修,牙科设备,真空柜

规格型号

型号	电机参数	转速RPM		功率		重量
		60Hz	50Hz	HP	KW	
无油式 压缩机						
RAA-P203-EB	110/115,50/60-1(二级)	1575	1275	1/4	0.19	8.60Kg
RAA-P203-GD	220/230,50/60-1(四级)	3000	2500	1/4	0.19	8.60Kg
无油式 真空泵						
RAA-V210-EB(并联)	110/115,50/60-1(四级)	1575	1275	1/4	0.19	8.60Kg
RAA-V211-EB(串联)	110/115,50/60-1(四级)	1575	1275	1/4	0.19	8.60Kg
RAA-V210-ED(并联)	220/230,50/60-1(四级)	1575	1275	1/4	0.19	8.60Kg
RAA-V211-ED(串联)	220/230,50/60-1(四级)	1575	1275	1/4	0.19	8.60Kg





产品尺寸 (mm, 英寸)

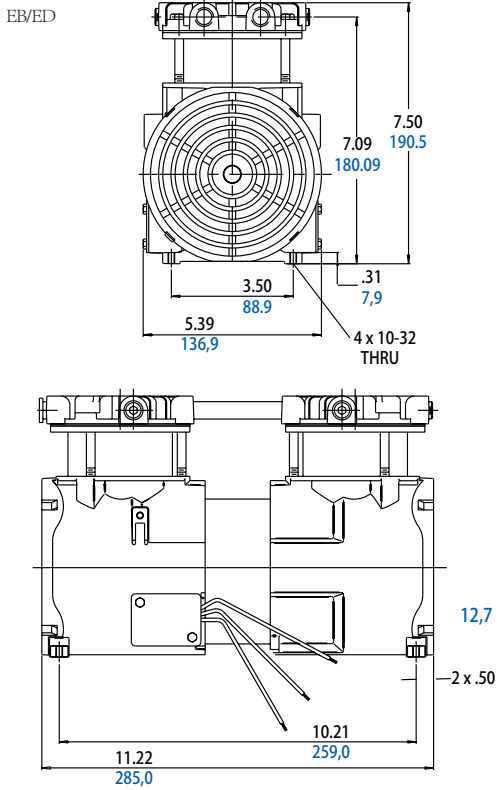

产品性能 (公制, 英制)

