



# Product Specification

E270HVZ-701

Preliminary Specifications

Final Specifications

Module	27 Inch Color TFT-LCD
Model Name	<b>E270HVZ-701</b> (HR270WU1-200)
Document Version	Rev.01

Customer	
_____	
Approved by	Date
_____	_____
Notice : This Specification is subject to change without notice.	

Approved By	Prepared By



**PRODUCT GROUP**

REV

ISSUE DATE

TFT- LCD PRODUCT

Rev.0

Feb.05. 15'

**REVISION HISTORY**

REV.	ECN No.	DESCRIPTION OF CHANGES	DATE	PREPARED
Rev.0	-	Initial Release	Feb.05. 15'	Yan Kai

SPEC. NUMBER S8-64-8A-077	SPEC. TITLE HR270WU1-200 Product Specification_Rev.0	PAGE 2 OF 30
------------------------------	---	-----------------



京东方  
BOE

PRODUCT GROUP

REV

ISSUE DATE

TFT- LCD PRODUCT

Rev.0

Feb.05. 15'

## Contents

No.	Item	Page
1.0	General Description	4
2.0	Absolute Maximum Ratings	6
3.0	Electrical Specifications	7
4.0	Optical Specifications	8
5.0	Interface Connection	10
6.0	Signal Timing Specifications	13
7.0	Signal Timing Waveforms of Interface Signal	15
8.0	Input Signals, Display Colors & Gray Scale of Colors	17
9.0	Power Sequence	18
10.0	Mechanical Characteristics	19
11.0	Reliability Test	20
12.0	Handling& Cautions	21
13.0	Product Serial Number	22
14.0	Packing	23
15.0	Appendix	25

SPEC. NUMBER

S8-64-8A-077

SPEC. TITLE

HR270WU1-200 Product Specification\_Rev.0

PAGE

3 OF 30

## 1.0 GENERAL DESCRIPTION

### 1.1 Introduction

HR270WU1-200 is a color active matrix TFT LCD module using amorphous silicon TFT's (Thin Film Transistors) as an active switching devices. This module has a 27.0 inch diagonally measured active area with FHD resolutions (1920 horizontal by 1080 vertical pixel array). Each pixel is divided into RED, GREEN, BLUE dots which are arranged in vertical stripe and this module can display 1.07B colors. The TFT-LCD panel used for this module is adapted for a low reflection and higher color type.

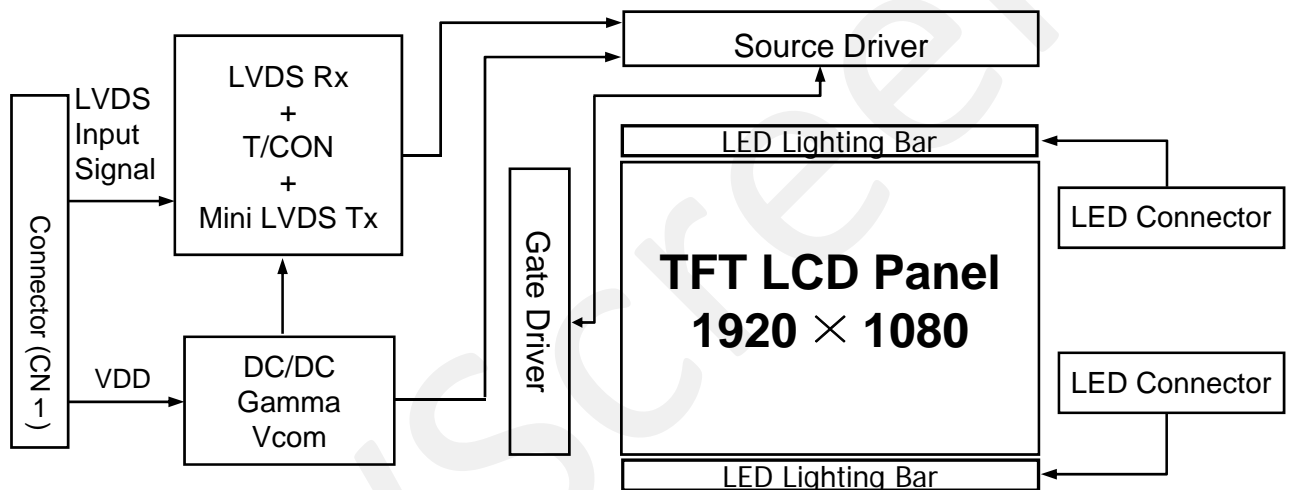

### 1.2 Features

- LVDS Interface with 2 pixel / clock
- High-speed response
- 10-bit (Real) color depth, display 1.07B colors
- Incorporated edge type back-light (LED)
- sRGB
- High luminance and contrast ratio, low reflection and wide viewing angle
- DE (Data Enable) only
- RoHS/Halogen Free
- Gamma Correction



# PRODUCT GROUP

REV

ISSUE DATE

TFT- LCD PRODUCT

Rev.0

Feb.05. 15'

### 1.3 Application

- Desktop Type of PC & Workstation Use
- Slim-Size Display for Stand-alone Monitor
- Display Terminals for Control System
- Monitors for Process Controller

### 1.4 General Specification

The followings are general specifications at the model HR270WU1-200.

<Table 1. General Specifications>

Parameter	Specification	Unit	Remarks
Active area	597.888(H) × 336.312(V)	mm	
Number of pixels	1920(H) × 1080(V)	pixels	
Pixel pitch	0.3114(H) × 0.3114(V)	mm	
Pixel arrangement	RGB Vertical stripe		
Display colors	1.07B	colors	
Display mode	Normally Black		
Dimensional outline	630(H) × 368.2(V) × 15.2 (D) typ.	mm	
Weight	3000 (Typ.)	g	
Surface Treatment	Haze 25%, 3H		
Back-light	Upper & lower edge side, 2-LED Lighting Bar type		Note 1
Power Consumption	P <sub>D</sub> : 8W (max)		
	P <sub>BL</sub> : 45.7W (max)		Note 2
	P <sub>total</sub> : 53.7(max)		

- Notes : 1. LED Lighting Bar (8\*input pins)  
 2. P<sub>LED</sub>=Input pins\* VPIN×IPIN

SPEC. NUMBER  
S8-64-8A-077

SPEC. TITLE  
HR270WU1-200 Product Specification\_Rev.0

PAGE  
5 OF 30

## 2.0 ABSOLUTE MAXIMUM RATINGS

The followings are maximum values which, if exceed, may cause faulty operation or damage to the unit. The operational and non-operational maximum voltage and current values are listed in Table 2.

< Table 2. Absolute Maximum Ratings >

[VSS=GND=0V]

Parameter	Symbol	Min.	Max.	Unit	Remarks
Power Supply Voltage	$V_{DD}$	-0.3	6.0	V	Ta = 25 °C
Logic Supply Voltage	$V_{IN}$	VSS-0.3	$V_{DD}+0.3$	V	
LED Light Bar Current Per Input Pin	IPIN	-	125	mA	
LED Light Bar Voltage Per Input Pin	VPIN	-	49	V	
Operating Temperature	$T_{OP}$	0	+50	°C	1)
Storage Temperature	$T_{ST}$	-20	+60	°C	1)

Note : 1) Temperature and relative humidity range are shown in the figure below.

Wet bulb temperature should be 39 °C max. and no condensation of water.

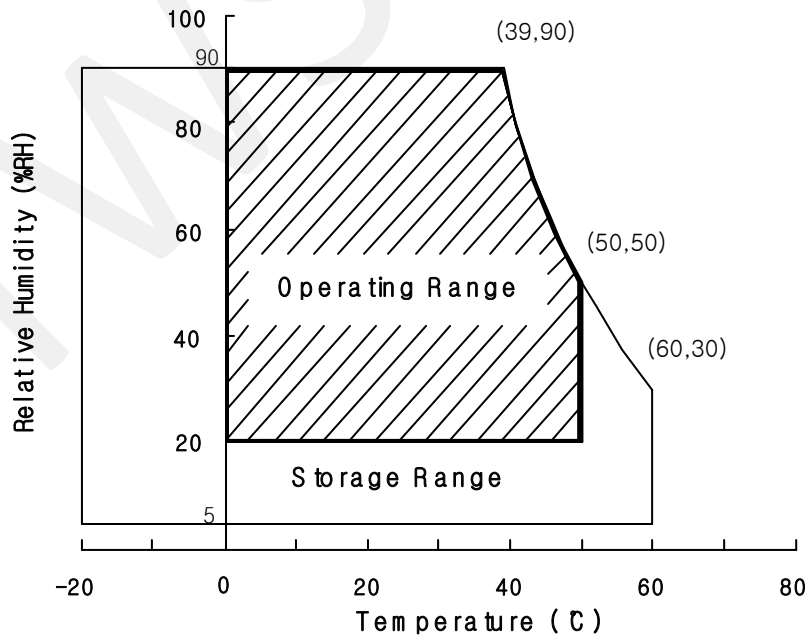

### 3.0 ELECTRICAL SPECIFICATIONS

#### 3.1 Electrical Specifications

< Table 3. Electrical specifications >

[Ta =25 ± 2 °C]

Parameter		Min.	Typ.	Max.	Unit	Remarks
Power Supply Voltage	V <sub>DD</sub>	4.5	5.0	5.5	V	Note1
Power Supply Current	I <sub>DD</sub>	-	1300	1600	mA	
In-Rush Current	I <sub>RUSH</sub>	-	2.0	3.0	A	Note 2
Permissible Input Ripple Voltage	V <sub>RF</sub>	-	-	100	mV	V <sub>DD</sub> = 5.0V
High Level Differential Input Threshold Voltage	V <sub>IH</sub>	-	-	+100	mV	
Low Level Differential Input Threshold Voltage	V <sub>IL</sub>	-100	-	-	mV	
Differential input voltage	V <sub>ID</sub>	200	-	600	mV	
Differential input common mode voltage	V <sub>cm</sub>	1.0	1.2	1.5		V <sub>IH</sub> =100mV, V <sub>IL</sub> =-100mV
Power Consumption	P <sub>D</sub>	-	6.5	8	W	
	P <sub>BL</sub>	-	43.0	45.7	W	Note 3
	P <sub>total</sub>	-	49.5	53.7	W	

Notes : 1. The supply voltage is measured and specified at the interface connector of LCM.  
The current draw and power consumption specified is for VDD=5.0V, Frame rate=60Hz  
Clock frequency = 74.25 MHz. Test Pattern of power supply current

- a) Typ : Color Test  
b) Max : Skip Subpixel255

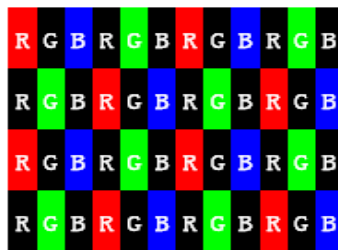

2. Duration of rush current is about 2 ms and rising time of VDD is 520 μs ± 20 %  
3. Calculated value for reference (Input pins\*VPIN × IPIN) excluding inverter loss.



PRODUCT GROUP

REV

ISSUE DATE

TFT- LCD PRODUCT

Rev.0

Feb.05. 15'

3.2 Backlight Unit

< Table 4. LED Backlight Unit >

Parameter		Min.	Typ.	Max.	Unit	Remarks
LED Light Bar Input Voltage Per Input Pin	VPIN	-	44.8	47.6	V	Duty 100%
LED Light Bar Input Current Per Input Pin	IPIN	-	120	-	mA	Note1,2,
LED Power Consumption	P <sub>BL</sub>	-	43.0	45.7	W	Note 3
LED Life-Time	-	30,000	-	-	Hrs	Note 4

Note1: There are two light bars ,and the specified current is input LED chip 100% duty current

Note2: The sense current of each input pin is 120mA

Note3: P<sub>BL</sub>=8 Input pins\*VPIN × IPIN

Note4: The lifetime is determined as the time at which luminance of LED become 50% of the initial brightness or not normal lighting at IPIN=120mA on condition of continuous operating at 25 ± 2 °C

SPEC. NUMBER  
S8-64-8A-077

SPEC. TITLE  
HR270WU1-200 Product Specification\_Rev.0

PAGE  
8 OF 30





# PRODUCT GROUP

REV

ISSUE DATE

TFT- LCD PRODUCT

Rev.0

Feb.05. 15'

## 4.0 OPTICAL SPECIFICATION

### 4.1 Overview

The test of Optical specifications shall be measured in a dark room (ambient luminance  $\leq 1$  lux and temperature =  $25 \pm 2^\circ\text{C}$ ) with the equipment of Luminance meter system (Goniometer system and TOPCONE BM-5) and test unit shall be located at an approximate distance 50cm from the LCD surface at a viewing angle of  $\theta$  and  $\Phi$  equal to  $0^\circ$ . We refer to  $\theta_{\theta=0}$  ( $=\theta_3$ ) as the 3 o'clock direction (the "right"),  $\theta_{\theta=90}$  ( $=\theta_{12}$ ) as the 12 o'clock direction ("upward"),  $\theta_{\theta=180}$  ( $=\theta_9$ ) as the 9 o'clock direction ("left") and  $\theta_{\theta=270}$  ( $=\theta_6$ ) as the 6 o'clock direction ("bottom"). While scanning  $\theta$  and/or  $\Phi$ , the center of the measuring spot on the Display surface shall stay fixed. The measurement shall be executed after 30 minutes warm-up period. VDD shall be 5.0V +/-10% at  $25^\circ\text{C}$ . Optimum viewing angle direction is 6 o'clock.

### 4.2 Optical Specifications

[VDD = 5.0V, Frame rate = 60Hz, Clock = 74.25MHz,  $I_{BL} = 120\text{mA} \times 8$ ,  $T_a = 25 \pm 2^\circ\text{C}$ ]

Parameter		Symbol	Condition	Min.	Typ.	Max.	Unit	Remark
Viewing Angle range	Horizontal	$\theta_3$	CR > 10	75	89	-	Deg.	Note 1
		$\theta_9$		75	89	-	Deg.	
	Vertical	$\theta_{12}$		70	89	-	Deg.	
		$\theta_6$		70	89	-	Deg.	
Luminance Contrast ratio		CR		700	1000	-		Note 2
Luminance of White		$Y_w$		725	-	-	cd/m <sup>2</sup>	Note 3
White luminance uniformity		$\Delta Y$		75	80	-	%	Note 4
Reproduction of color	White	$W_x$	$\theta = 0^\circ$ (Center) Normal Viewing Angle	0.283	0.313	0.343	-	Note 5
		$W_y$		0.299	0.329	0.359	-	
	Red	$R_x$		0.615	0.645	0.675	-	
		$R_y$		0.298	0.328	0.358	-	
	Green	$G_x$		0.273	0.303	0.333	-	
		$G_y$		0.588	0.618	0.648	-	
	Blue	$B_x$		0.118	0.148	0.178	-	
		$B_y$		0.030	0.060	0.090	-	
Response Time	GTG	$T_g$		14	20	ms	Note 6	
Cross Talk		CT		-	-	2.0	%	Note 7

SPEC. NUMBER  
S8-64-8A-077

SPEC. TITLE  
HR270WU1-200 Product Specification\_Rev.0

PAGE  
9 OF 30



PRODUCT GROUP

REV

ISSUE DATE

TFT- LCD PRODUCT

Rev.0

Feb.05. 15'

Note :

- Viewing angle is the angle at which the contrast ratio is greater than 10. The viewing are determined for the horizontal or 3, 9 o'clock direction and the vertical or 6, 12 o'clock direction with respect to the optical axis which is normal to the LCD surface.
- Contrast measurements shall be made at viewing angle of  $\theta = 0^\circ$  and at the center of the LCD surface. Luminance shall be measured with all pixels in the view field set first to white, then to the dark (black) state. (See FIGURE 1 shown in Appendix) Luminance Contrast Ratio (CR) is defined mathematically.

$$CR = \frac{\text{Luminance when displaying a white raster}}{\text{Luminance when displaying a black raster}}$$

- Center Luminance of white is defined as the LCD surface. Luminance shall be measured with all pixels in the view field set first to white. This measurement shall be taken at the locations shown in FIGURE 2 for a total of the measurements per display.
- The White luminance uniformity on LCD surface is then expressed as :  
 $\Delta Y = (\text{Minimum Luminance of 9points} / \text{Maximum Luminance of 9points}) * 100$   
 (See FIGURE 2 shown in Appendix).
- The color chromaticity coordinates specified in Table 4. shall be calculated from the spectral data measured with all pixels first in red, green, blue and white. Measurements shall be made at the center of the panel.
- Response time Tg is the average time required for display transition by switching the input signal as below table and is based on Frame rate fV =60Hz to optimize.  
 Each time in below table is defined as Figure 3and shall be measured by switching the input signal for “any level of gray(bright)”and “any level of gray(dark)”.

Measured Response Time	Target																
	0	15	31	47	63	79	95	111	127	143	159	175	191	207	223	239	255
0																	
15																	
31																	
47																	
63																	
79																	
95																	
111																	
127																	
143																	
159																	
175																	
191																	
207																	
223																	
239																	
255																	

- Cross-Talk of one area of the LCD surface by another shall be measured by comparing the luminance ( $Y_A$ ) of a 25mm diameter area, with all display pixels set to a gray level, to the luminance ( $Y_B$ ) of that same area when any adjacent area is driven dark. (See FIGURE 4 shown in Appendix).

SPEC. NUMBER  
S8-64-8A-077

SPEC. TITLE  
HR270WU1-200 Product Specification\_Rev.0

PAGE  
10 OF 30

## 5.0 INTERFACE CONNECTION.

### 5.1 Electrical Interface Connection

#### 5.1.1 LED Light Bar

< Table 1. LED Light Bar >

Pin No	Description
1	LED current sense for string1
2	LED current sense for string2
3	LED power supply
4	LED power supply
5	LED current sense for string3
6	LED current sense for string4
7	LED current sense for string5
8	LED current sense for string6
9	LED power supply
10	LED power supply
11	LED current sense for string7
12	LED current sense for string8
CONNECTOR	3707K-Q06N-08X



Figure1. Top View of LED Bar Connector

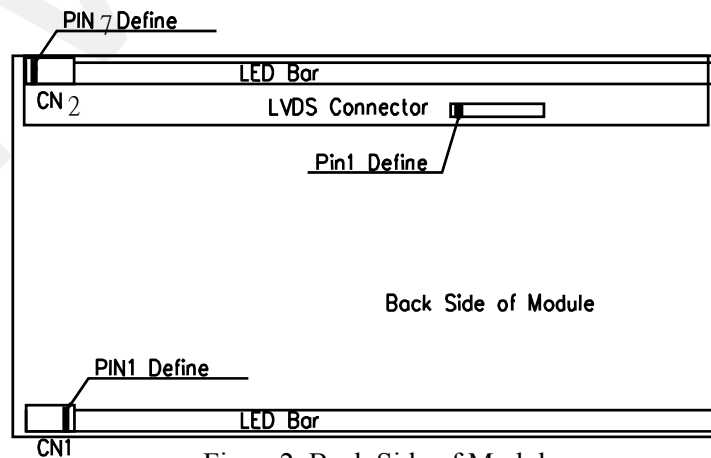

Figure2. Back Side of Module



# PRODUCT GROUP

REV

ISSUE DATE

TFT- LCD PRODUCT

Rev.0

Feb.05. 15'

## 5.1 2Electrical Interface Connection

- CN1            Module Side Connector : UJU IS050-C51B-C39-S or Equivalent

NO.	Symbol	Description	NO.	Symbol	Description
1	NC	not connection	27	NC	not connection
2	NC	not connection	28	2LVDSAN	SECOND LVDS Receiver Signal (A-)
3	SDAPG	SDA_P-Gamma	29	2LVDSAP	SECOND LVDS Receiver Signal (A+)
4	SCLPG	SCL_P-Gamma	30	2LVDSBN	SECOND LVDS Receiver Signal (B-)
5	BISTSEL	Bist selection	31	2LVDSBP	SECOND LVDS Receiver Signal (B+)
6	NC	not connection	32	2LVDS CN	SECOND LVDS Receiver Signal (C-)
7	NC	not connection	33	2LVDS CP	SECOND LVDS Receiver Signal (C+)
8	NC	not connection	34	GND	ground
9	NC	not connection	35	2CLKN	SECOND LVDS Receiver Clock Signal (-)
10	NC	not connection	36	2CLKP	SECOND LVDS Receiver Clock Signal (+)
11	GND	ground	37	GND	ground
12	1LVDSAN	FIRST LVDS Receiver Signal (A-)	38	2LVDS DN	SECOND LVDS Receiver Signal (D-)
13	1LVDSAP	FIRST LVDS Receiver Signal (A+)	39	2LVDS DP	SECOND LVDS Receiver Signal (D+)
14	1LVDSBN	FIRST LVDS Receiver Signal (B-)	40	2LVDS EN	SECOND LVDS Receiver Signal (E-)
15	1LVDSBP	FIRST LVDS Receiver Signal (B+)	41	2LVDS EP	SECOND LVDS Receiver Signal (E+)
16	1LVDS CN	FIRST LVDS Receiver Signal (C-)	42	NC	not connection
17	1LVDS CP	FIRST LVDS Receiver Signal (C+)	43	NC	not connection
18	GND	ground	44	GND	ground
19	1CLKN	FIRST LVDS Receiver Clock Signal(-)	45	GND	ground
20	1CLKP	FIRST LVDS Receiver Clock Signal(+)	46	GND	ground
21	GND	ground	47	NC	not connection
22	1LVDS DN	FIRST LVDS Receiver Signal (D-)	48	Power	power supply
23	1LVDS DP	FIRST LVDS Receiver Signal (D+)	49	Power	power supply
24	1LVDS EN	FIRST LVDS Receiver Signal (E-)	50	Power	power supply
25	1LVDS EP	FIRST LVDS Receiver Signal (E+)	51	Power	power supply
26	GND	ground			

SPEC. NUMBER  
S8-64-8A-077

SPEC. TITLE  
HR270WU1-200 Product Specification\_Rev.0

PAGE  
12 OF 30



**PRODUCT GROUP**

REV

ISSUE DATE

TFT- LCD PRODUCT

Rev.0

Feb.05. 15'

**5.2 LVDS Interface (Tx; THC63LVD1023B or Equivalent)**

**5.2.1 LVDS Interface**

	Input Signal	Transmitter		Interface		HR270WU1-200	Remark
		Pin No.	Pin No.	System(Tx)	TFT-LCD (Rx)	(CN1)Pin No.	
L V D S	R4	80	70,71	OUT0- OUT0+	RX0- RX0+	12,13	
	R5	81					
	R6	84					
	R7	85					
	R8	86					
	R9	87					
	G4	92	68,69	OUT1- OUT1+	RX1- RX1+	14,15	
	G5	95					
	G6	96					
	G7	97					
	G8	98					
	G9	99					
	B4	106	64,65	OUT2- OUT2+	RX2- RX2+	16,17	
	B5	107					
	B6	108					
	B7	110					
	B8	111					
	B9	112					
	HS	7	62,63	CLK OUT- CLK OUT-	RX CLK- RX CLK+	19,20	
	VS	8					
	DE	9	58,59	OUT3- OUT3+	RX3- RX3+	22,23	
	MCLK	15					
		16					
	R2	78					
	R3	79					
	G2	90					
	G3	91	56,57	OUT4- OUT4+	RX4- RX4+	24,25	
	B2	102					
B3	103						
-							
R0	76						
R1	77						
G0	88	56,57	OUT4- OUT4+	RX4- RX4+	24,25		
G1	89						
B0	100						
B1	101						

SPEC. NUMBER  
S8-64-8A-077

SPEC. TITLE  
HR270WU1-200 Product Specification\_Rev.0

PAGE  
13 OF 30

### 5.3 Data Input Format

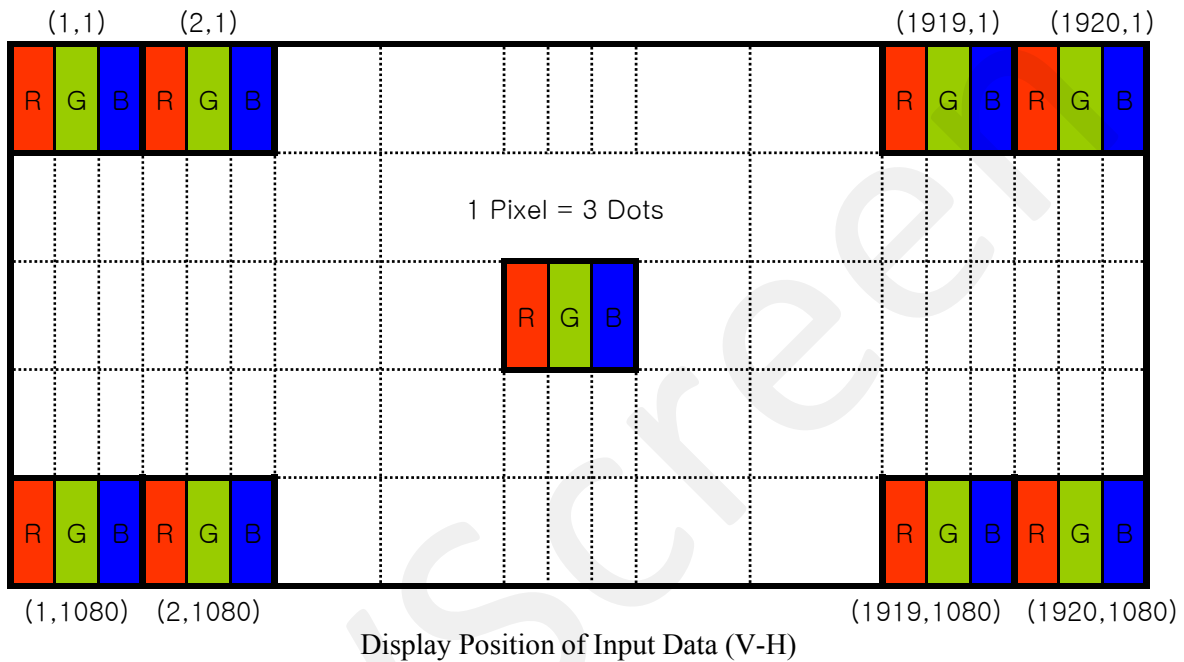



PRODUCT GROUP

REV

ISSUE DATE

TFT- LCD PRODUCT

Rev.0

Feb.05. 15'

6.0 SIGNAL TIMING SPECIFICATION

6.1 The HR270WU1-200 is operated by the DE only.

Item		Symbols	Min	Typ	Max	Unit
Clock	Frequency	1/Tc	-	74.25	-	MHz
	High Time	Tch	-	4/7Tc	-	
	Low Time	Tcl	-	4/7Tc	-	
Frame Period		Tv	-	1126	-	lines
			-	60	-	Hz
			-	16.7	-	ms
Vertical Display Period		Tvd	-	1080	-	lines
One line Scanning Period		Th	-	1100	-	clocks
Horizontal Display Period		Thd	-	960	-	clocks

SPEC. NUMBER  
S8-64-8A-077

SPEC. TITLE  
HR270WU1-200 Product Specification\_Rev.0

PAGE  
15 OF 30

### 6.2 LVDS Rx Interface Timing Parameter

The specification of the LVDS Rx interface timing parameter is shown in Table 4.

<Table 4. LVDS Rx Interface Timing Specification>

Item	Symbol	Min	Typ	Max	Unit	Remark
CLKIN Period	tRCIP	10.20	13.47	17.08	nsec	
Input Data 0	tRIP1	-0.4	0.0	+0.4	nsec	
Input Data 1	tRIP0	tRCIP/7-0.4	tRCIP/7	tRCIP/7+0.4	nsec	
Input Data 2	tRIP6	2 × tRCIP/7-0.4	2 × tRCIP/7	2 × tRCIP/7+0.4	nsec	
Input Data 3	tRIP5	3 × tRCIP/7-0.4	3 × tRCIP/7	3 × tRCIP/7+0.4	nsec	
Input Data 4	tRIP4	4 × tRCIP/7-0.4	4 × tRCIP/7	4 × tRCIP/7+0.4	nsec	
Input Data 5	tRIP3	5 × tRCIP/7-0.4	5 × tRCIP/7	5 × tRCIP/7+0.4	nsec	
Input Data 6	tRIP2	6 × tRCIP/7-0.4	6 × tRCIP/7	6 × tRCIP/7+0.4	nsec	

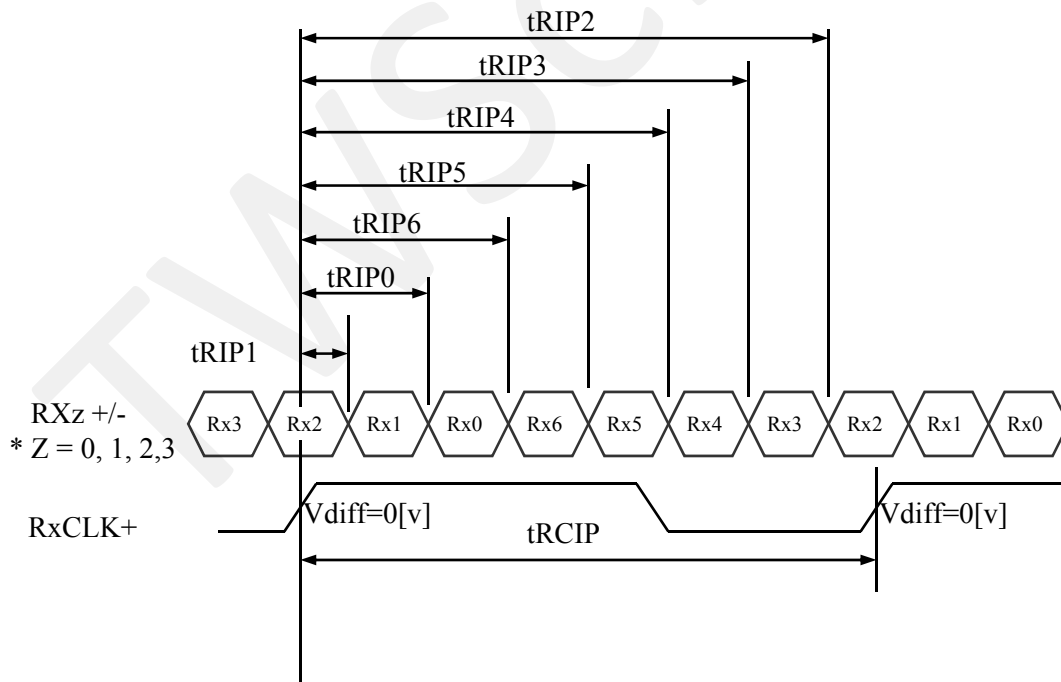

\*  $V_{diff} = (RXz+) - (RXz-), \dots, (RXCLK+) - (RXCLK-)$



## 7.0 SIGNAL TIMING WAVEFORMS OF INTERFACE SIGNAL

### 7.1 Sync Timing Waveforms

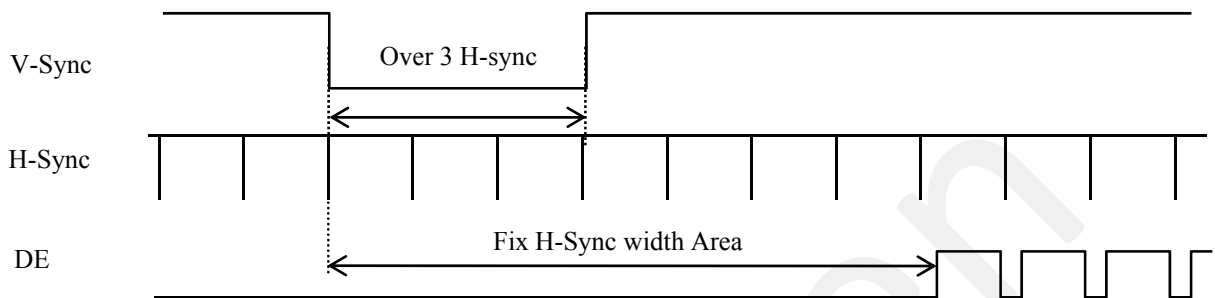

- 1) Need over 3 H-sync during V-Sync Low
- 2) Fix H-Sync width from V-Sync falling edge to first rising edge

### 7.2 Vertical Timing Waveforms

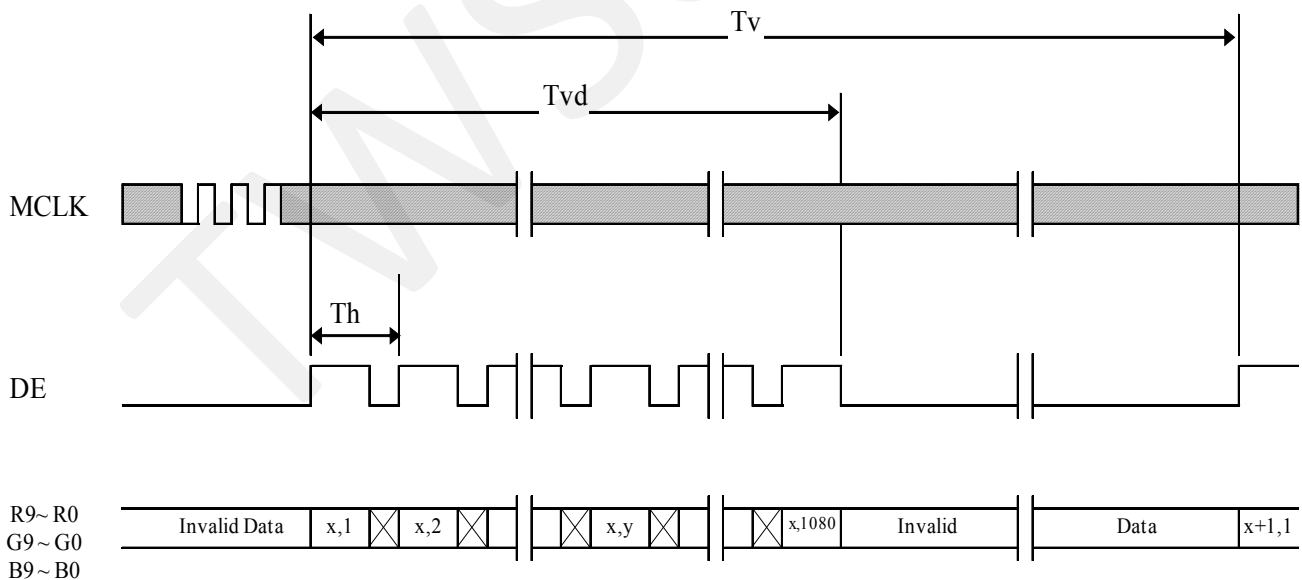

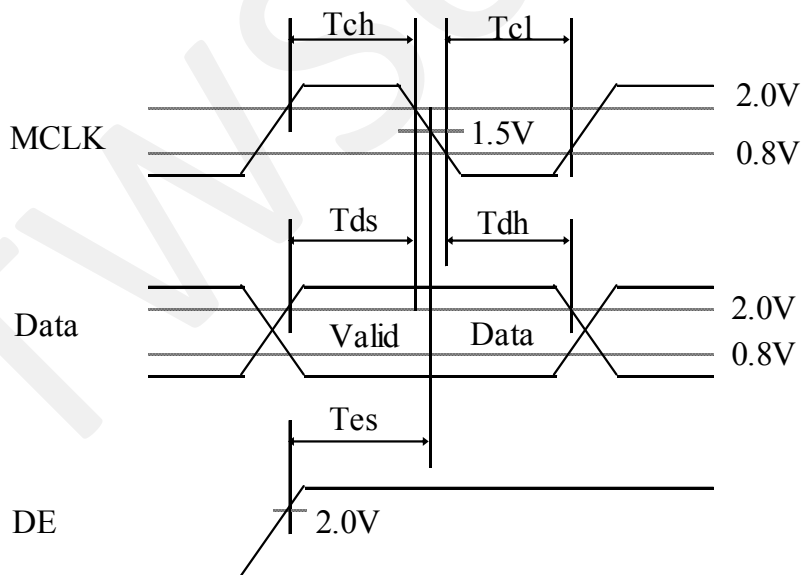
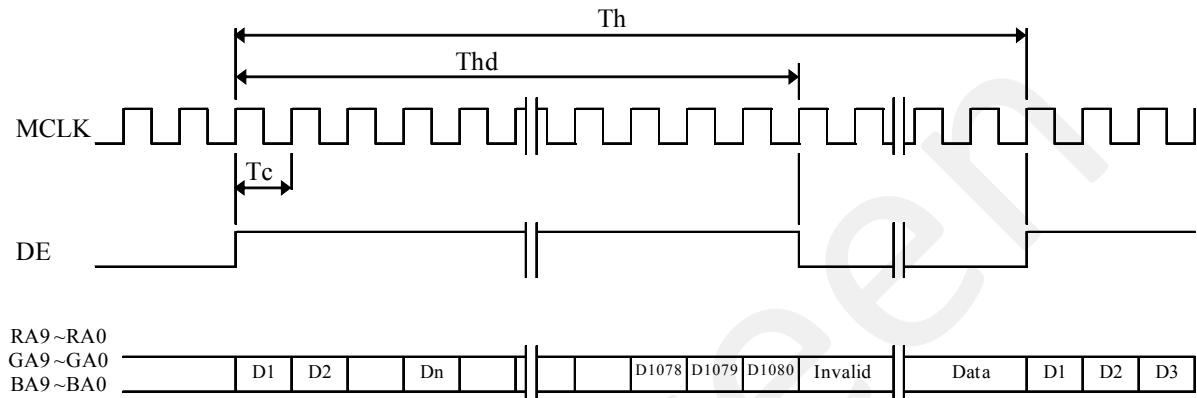
**7.3 Horizontal Timing Waveforms**



**PRODUCT GROUP**

REV

ISSUE DATE

TFT- LCD PRODUCT

Rev.0

Feb.05. 15'

**8.0 INPUT SIGNALS, BASIC DISPLAY COLORS & GRAY SCALE OF COLORS**

Color & Gray Scale		RED DATA									GREEN DATA									BLUE DATA										
		R9	R8	R7	R6	R5	R4	R3	R2	R1	R0	R9	R8	G7	G6	G5	G4	G3	G2	G1	G0	R9	R8	B7	B6	B5	B4	B3	B2	B1
Basic Colors	Black	0	0	0	0	0	0	0	0	0	0	0	0	0	0	0	0	0	0	0	0	0	0	0	0	0	0	0	0	0
	Blue	0	0	0	0	0	0	0	0	0	0	0	0	0	0	0	0	0	0	0	1	1	1	1	1	1	1	1	1	1
	Green	0	0	0	0	0	0	0	0	0	1	1	1	1	1	1	1	1	1	1	0	0	0	0	0	0	0	0	0	0
	Cyan	0	0	0	0	0	0	0	0	0	1	1	1	1	1	1	1	1	1	1	1	1	1	1	1	1	1	1	1	1
	Red	1	1	1	1	1	1	1	1	1	0	0	0	0	0	0	0	0	0	0	0	0	0	0	0	0	0	0	0	0
	Magenta	1	1	1	1	1	1	1	1	1	0	0	0	0	0	0	0	0	0	0	1	1	1	1	1	1	1	1	1	1
	Yellow	1	1	1	1	1	1	1	1	1	1	1	1	1	1	1	1	1	1	1	0	0	0	0	0	0	0	0	0	0
	White	1	1	1	1	1	1	1	1	1	1	1	1	1	1	1	1	1	1	1	1	1	1	1	1	1	1	1	1	1
Gray Scale of RED	Black	0	0	0	0	0	0	0	0	0	0	0	0	0	0	0	0	0	0	0	0	0	0	0	0	0	0	0	0	
	△	0	0	0	0	0	0	0	0	0	0	0	0	0	0	0	0	0	0	0	0	0	0	0	0	0	0	0	0	
	Darker	0	0	0	0	0	0	0	1	0	0	0	0	0	0	0	0	0	0	0	0	0	0	0	0	0	0	0	0	
	△	↑									↑									↑										
	▽	↓									↓									↓										
	Brighter	1	1	1	1	1	1	1	0	1	0	0	0	0	0	0	0	0	0	0	0	0	0	0	0	0	0	0	0	
	▽	1	1	1	1	1	1	1	1	0	0	0	0	0	0	0	0	0	0	0	0	0	0	0	0	0	0	0	0	
	Red	1	1	1	1	1	1	1	1	1	0	0	0	0	0	0	0	0	0	0	0	0	0	0	0	0	0	0	0	
Gray Scale of GREEN	Black	0	0	0	0	0	0	0	0	0	0	0	0	0	0	0	0	0	0	0	0	0	0	0	0	0	0	0		
	△	0	0	0	0	0	0	0	0	0	0	0	0	0	0	0	0	0	0	1	0	0	0	0	0	0	0	0		
	Darker	0	0	0	0	0	0	0	0	0	0	0	0	0	0	0	0	1	0	0	0	0	0	0	0	0	0	0		
	△	↑									↑									↑										
	▽	↓									↓									↓										
	Brighter	0	0	0	0	0	0	0	0	0	1	1	1	1	1	1	1	0	1	0	0	0	0	0	0	0	0	0	0	
	▽	0	0	0	0	0	0	0	0	0	1	1	1	1	1	1	1	1	0	0	0	0	0	0	0	0	0	0	0	
	Green	0	0	0	0	0	0	0	0	0	1	1	1	1	1	1	1	1	1	0	0	0	0	0	0	0	0	0	0	
Gray Scale of BLUE	Black	0	0	0	0	0	0	0	0	0	0	0	0	0	0	0	0	0	0	0	0	0	0	0	0	0	0	0		
	△	0	0	0	0	0	0	0	0	0	0	0	0	0	0	0	0	0	0	0	0	0	0	0	0	0	0	1		
	Darker	0	0	0	0	0	0	0	0	0	0	0	0	0	0	0	0	0	0	0	0	0	0	0	0	0	1	0		
	△	↑									↑									↑										
	▽	↓									↓									↓										
	Brighter	0	0	0	0	0	0	0	0	0	0	0	0	0	0	0	0	0	0	1	1	1	1	1	1	1	1	0	1	
	▽	0	0	0	0	0	0	0	0	0	0	0	0	0	0	0	0	0	0	1	1	1	1	1	1	1	1	1	0	
	Blue	0	0	0	0	0	0	0	0	0	0	0	0	0	0	0	0	0	0	1	1	1	1	1	1	1	1	1	1	
Gray Scale of WHITE	Black	0	0	0	0	0	0	0	0	0	0	0	0	0	0	0	0	0	0	0	0	0	0	0	0	0	0	0		
	△	0	0	0	0	0	0	0	1	0	0	0	0	0	0	0	0	0	0	1	0	0	0	0	0	0	0	1		
	Darker	0	0	0	0	0	0	0	1	0	0	0	0	0	0	0	0	1	0	0	0	0	0	0	0	0	1	0		
	△	↑									↑									↑										
	▽	↓									↓									↓										
	Brighter	1	1	1	1	1	1	1	0	1	1	1	1	1	1	1	1	0	1	1	1	1	1	1	1	1	1	0	1	
	▽	1	1	1	1	1	1	1	1	0	1	1	1	1	1	1	1	1	0	1	1	1	1	1	1	1	1	1	0	
	White	1	1	1	1	1	1	1	1	1	1	1	1	1	1	1	1	1	1	1	1	1	1	1	1	1	1	1	1	

SPEC. NUMBER  
S8-64-8A-077

SPEC. TITLE  
HR270WU1-200 Product Specification\_Rev.0

PAGE  
19 OF 30

## 9.0 POWER SEQUENCE

To prevent a latch-up or DC operation of the LCD module, the power on/off sequence shall be as shown in below

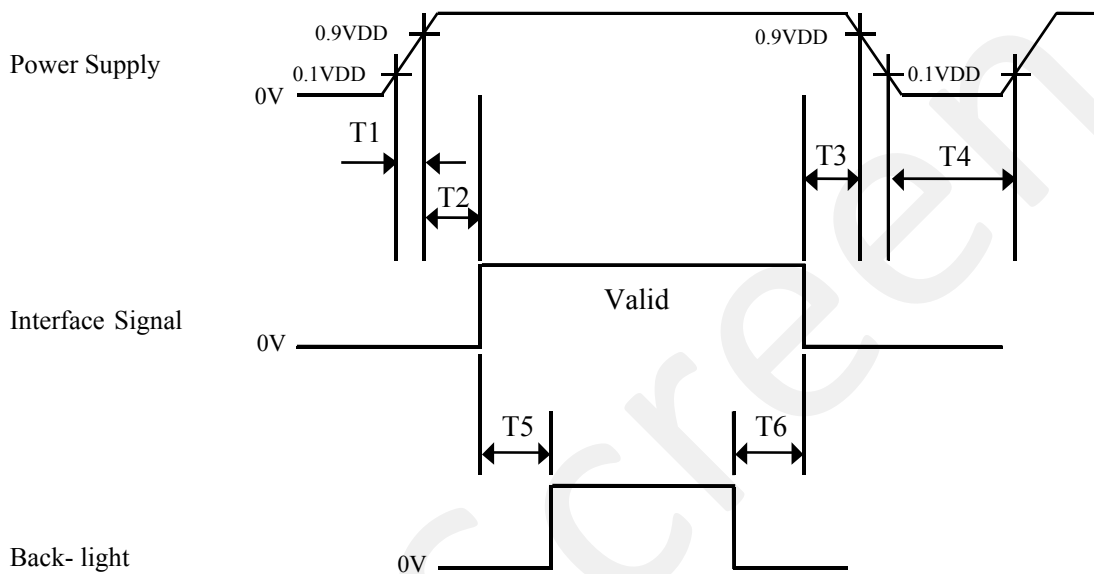

- $0.5 \text{ ms} \leq T1 \leq 10 \text{ ms}$
- $0 \leq T2 \leq 50 \text{ ms}$
- $0 \leq T3 \leq 50 \text{ ms}$
- $1 \text{ sec} \leq T4$
- $200 \text{ ms} \leq T5$
- $200 \text{ ms} \leq T6$

### Notes:

1. When the power supply VDD is 0V, keep the level of input signals on the low or keep high impedance.
2. Do not keep the interface signal high impedance when power is on.
3. Back Light must be turn on after power for logic and interface signal are valid.



# PRODUCT GROUP

REV

ISSUE DATE

TFT- LCD PRODUCT

Rev.0

Feb.05. 15'

## 10.0 MECHANICAL CHARACTERISTICS

### 10.1 Dimensional Requirements

FIGURE 6 (located in Appendix) shows mechanical outlines for the model HR270WU1-200. Other parameters are shown in Table 5.

<Table 5. Dimensional Parameters>

Parameter	Specification	Unit
Dimensional outline	630(H) × 368.2(V) × 15.2(D) typ	mm
Weight	3000(typ)	gram
Active area	597.888 (H) × 336.312 (V)	mm
Pixel pitch	0.3114 (H) × 0.3114 (V)	mm
Number of pixels	1920 (H) × 1080 (V) (1 pixel = R + G + B dots)	pixels
Back-light	Up & lower edge side, 2-LED Lighting Bar type	

### 10.2 Mounting

Refer to Figure 5 (Show in Appendix).

### 10.3 Anti-Glare and Polarizer Hardness.

The surface of the LCD has an anti-glare coating to minimize reflection and a coating to reduce scratching.

### 10.4 Light Leakage

There shall not be visible light from the back-lighting system around the edges of the screen as seen from a distance 50cm from the screen with an overhead light level of 350lux.

SPEC. NUMBER  
S8-64-8A-077

SPEC. TITLE  
HR270WU1-200 Product Specification\_Rev.0

PAGE  
21 OF 30



**PRODUCT GROUP**

REV

ISSUE DATE

TFT- LCD PRODUCT

Rev.0

Feb.05. 15'

**11.0 RELIABILITY TEST**

The Reliability test items and its conditions are shown in below.

<Table 6. Reliability Test Parameters >

No	Test Items	Conditions	
1	High temperature storage test	Ta = 60 °C, 240 hrs	
2	Low temperature storage test	Ta = -20 °C, 240 hrs	
3	High temperature & high humidity operation test	Ta = 50 °C, 80%RH, 240hrs	
4	High temperature operation test	Ta = 50 °C, 240hrs	
5	Low temperature operation test	Ta = 0°C, 240hrs	
6	Thermal shock	Ta = -20 °C ↔ 60 °C (0.5 hr), 100 cycle	
7	On/Off Operation Test	1min(on) / 1min(off), 30000cycle	
8	Vibration test (non-operating)	Frequency	Random, 10 ~ 300 Hz, 30 min/Axis
		Gravity / AMP	1.5 Grms
		Period	X, Y, Z 30 min
9	Shock test (non-operating)	Gravity	50G
		Pulse width	11msec, sine wave
		Direction	± X, ± Y, ± Z Once for each
10	Packing Vibration( Module)	1.2Grms, 1~200Hz, Random +Z/60min, X/30min, Y/30min	
11	Drop Test (Module)	1Angle,3Edge,6Face. Height: Based on JIS-Z-0200	
12	Electro-static discharge test (non-operating)	Air : 150 pF, 330Ω, 15 KV	Contact : 150 pF, 330Ω, 8 KV

SPEC. NUMBER  
S8-64-8A-077

SPEC. TITLE  
HR270WU1-200 Product Specification\_Rev.0

PAGE  
22 OF 30

 <b>京东方</b> <b>BOE</b>	<b>PRODUCT GROUP</b>	REV	ISSUE DATE
	TFT- LCD PRODUCT	Rev.0	Feb.05. 15'

## 12.0 HANDLING & CAUTIONS

- (1) Cautions when taking out the module
  - Pick the pouch only, when taking out module from a shipping package.
- (2) Cautions for handling the module
  - As the electrostatic discharges may break the LCD module, handle the LCD module with care. Peel a protection sheet off from the LCD panel surface as slowly as possible.
  - As the LCD panel and back - light element are made from fragile glass material, impulse and pressure to the LCD module should be avoided.
  - As the surface of the polarizer is very soft and easily scratched, use a soft dry cloth without chemicals for cleaning.
  - Do not pull the interface connector in or out while the LCD module is operating.
  - Put the module display side down on a flat horizontal plane.
  - Handle connectors and cables with care.
- (3) Cautions for the operation
  - When the module is operating, do not lose CLK, ENAB signals. If any one of these signals is lost, the LCD panel would be damaged.
  - Obey the supply voltage sequence. If wrong sequence is applied, the module would be damaged.
- (4) Cautions for the atmosphere
  - Dew drop atmosphere should be avoided.
  - Do not store and/or operate the LCD module in a high temperature and/or humidity atmosphere. Storage in an electro-conductive polymer packing pouch and under relatively low temperature atmosphere is recommended.
- (5) Cautions for the module characteristics
  - Do not apply fixed pattern data signal to the LCD module at product aging.
  - Applying fixed pattern for a long time may cause image sticking.
- (6) Other cautions
  - Do not disassemble and/or re-assemble LCD module.
  - Do not re-adjust variable resistor or switch etc.
  - When returning the module for repair or etc., Please pack the module not to be broken. We recommend to use the original shipping packages.

SPEC. NUMBER S8-64-8A-077	SPEC. TITLE HR270WU1-200 Product Specification_Rev.0	PAGE 23 OF 30
------------------------------	---	------------------



PRODUCT GROUP

REV

ISSUE DATE

TFT- LCD PRODUCT

Rev.0

Feb.05. 15'

13.0 PRODUCT SERIAL NUMBER



HR270WU1-200

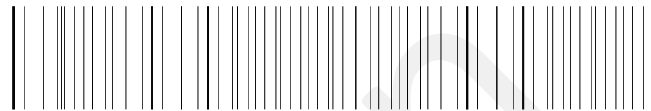

XXXXXXXXXXXXXXXXXXXX

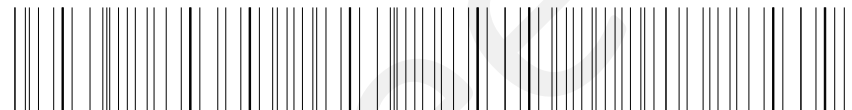

MADE IN CHINA XXXXXXXXXXXXXXXXXXXXXXX

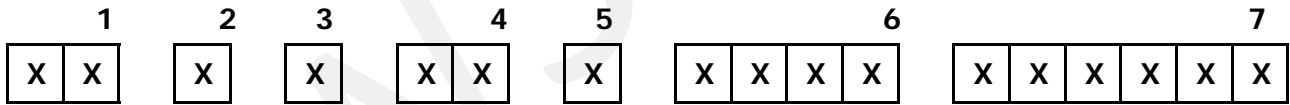

- 1. Control Number
- 2. Rank / Grade
- 3. Line Classification
- 4. Year (2001 : 01, 2002 : 02, ...)
- 5. Month (1,2,3, ... , 9, X, Y, Z)
- 6. Internal Use
- 7. Serial Number

SPEC. NUMBER  
S8-64-8A-077

SPEC. TITLE  
HR270WU1-200 Product Specification\_Rev.0

PAGE  
24 OF 30



## 14.0 Packing

### 14.1 Packing Order

Place the modules into the box;  
Notice front and rear , 5 modules per box

place a cover on the top of the box

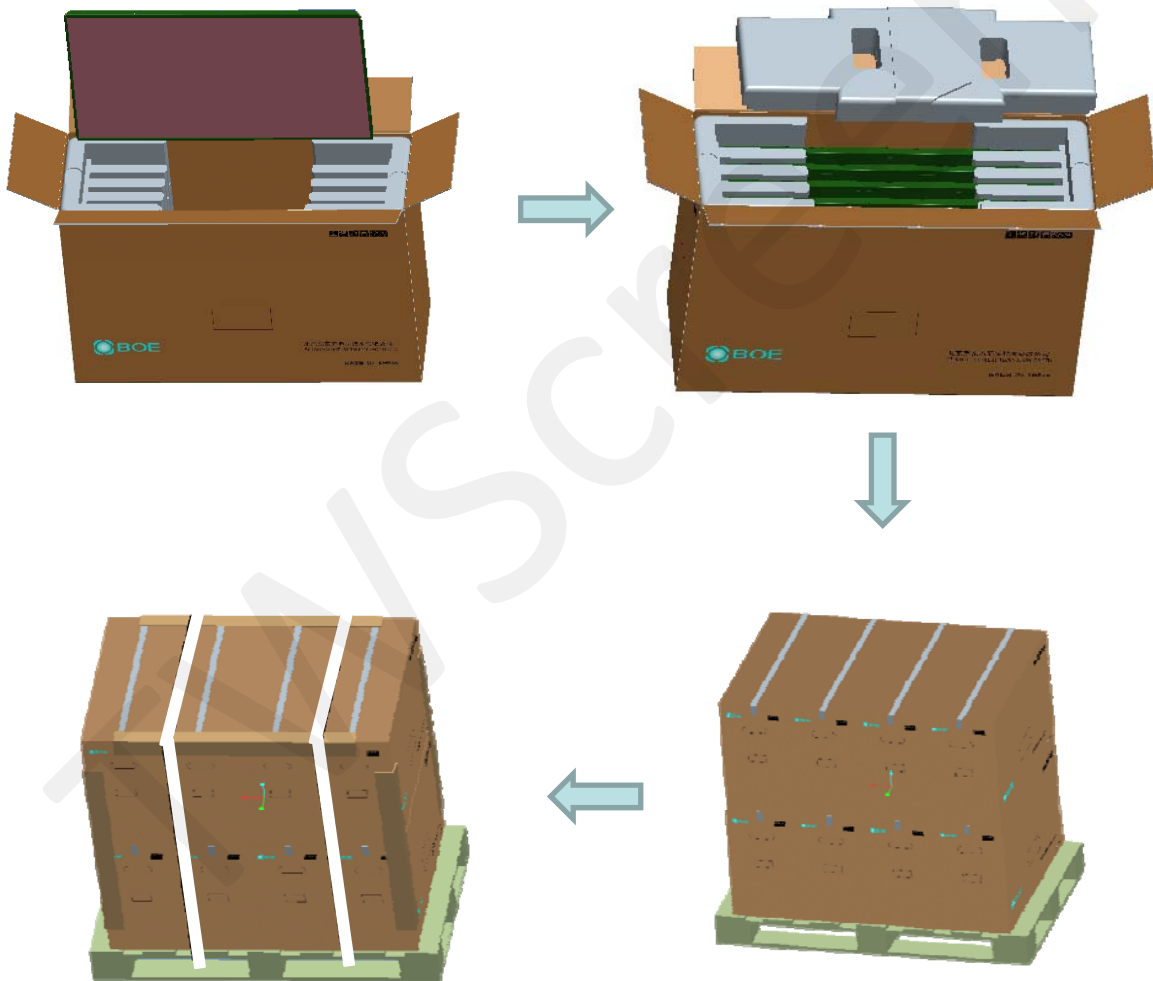

Sea box per pallet

After sealing the box, put the box on the pallet



# PRODUCT GROUP

REV

ISSUE DATE

TFT- LCD PRODUCT

Rev.0

Feb.05. 15'

### 14.2 Packing Note

- See next page for detail description.  
Date : Packing Date  
Box Dimension : 235mm(W) × 715mm(L) × 485mm(H)
- Package Quantity in one Box : 5 pcs

### 14.3 Box label

- Label Size : 108 mm (L) × 56 mm (W)
- Contents  
Model : HR270WU1-200  
Q`ty : Module Q`ty in one box  
Serial No. : Box Serial No

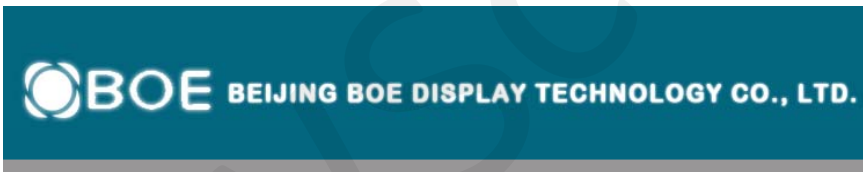

MODEL : HR270WU1-200 Q'TY : 5

SERIAL NO. : 0000000000000000 DATE : 20XX.X.XX



• QAA0330000268 •

4940



(QA)

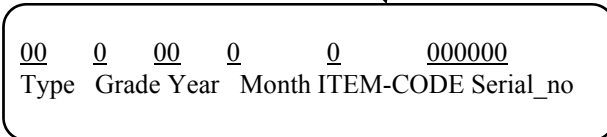

Internal Use

RoHS Mark

SPEC. NUMBER  
S8-64-8A-077

SPEC. TITLE  
HR270WU1-200 Product Specification\_Rev.0

PAGE  
26 OF 30

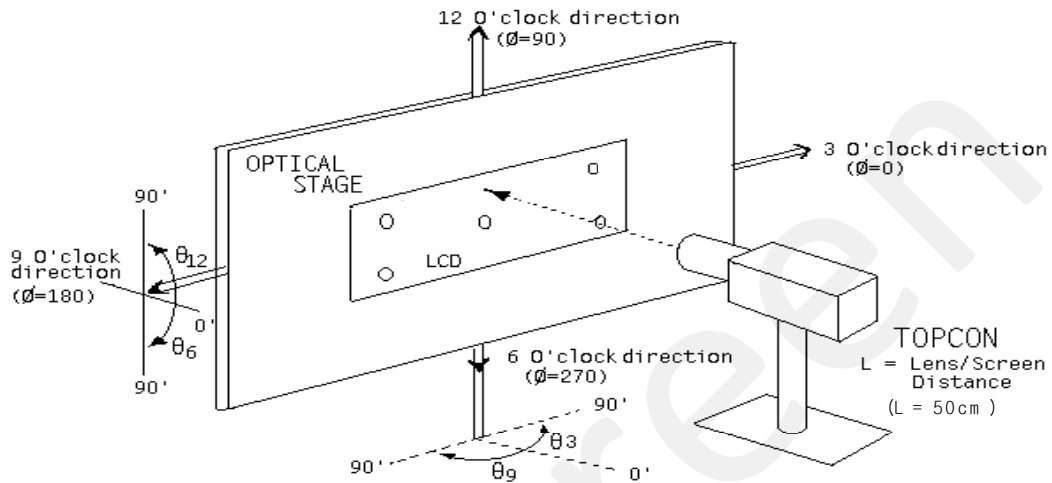
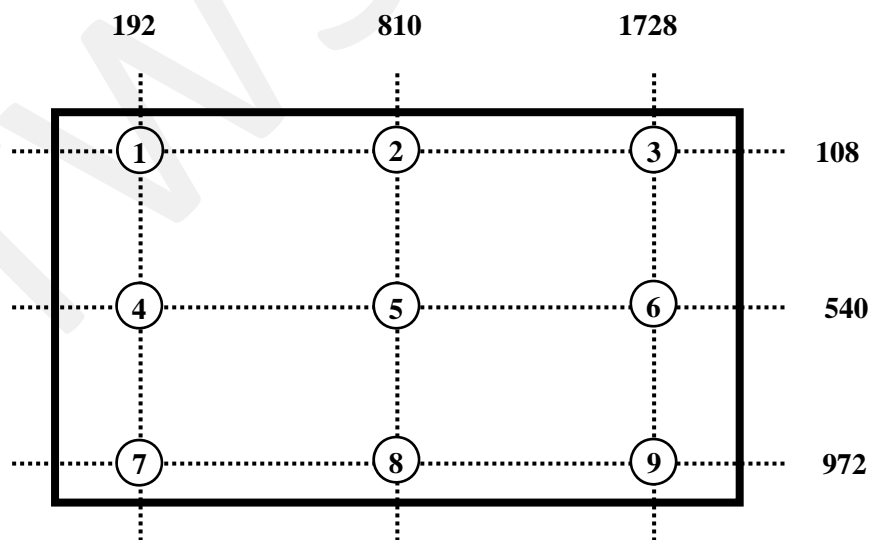
**15.0 APPENDIX**
**Figure 1. Measurement Set Up**

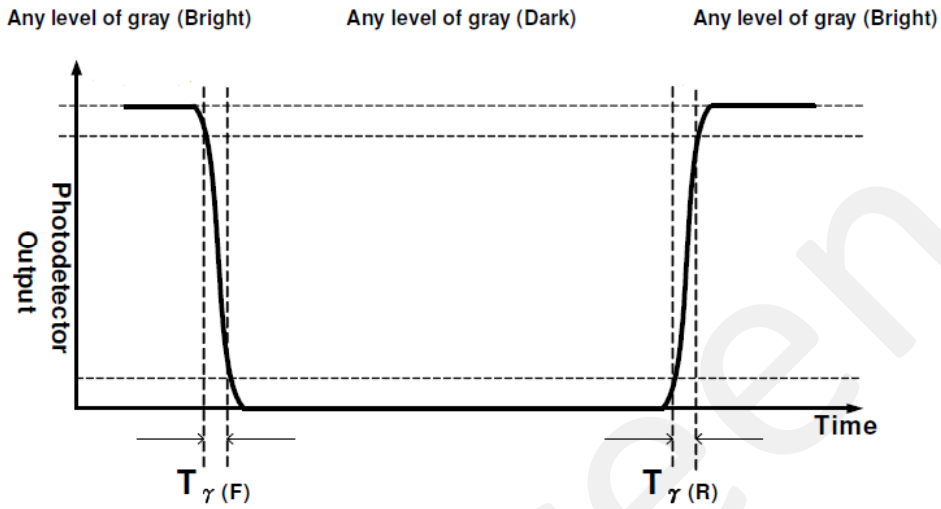
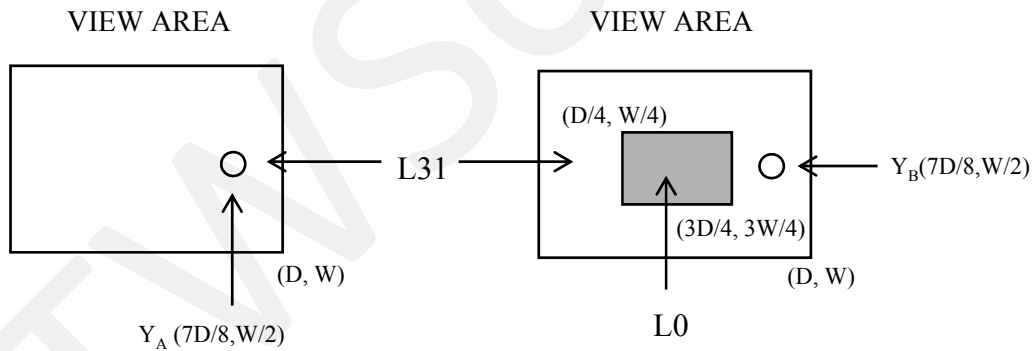
**Figure 2. White Luminance and Uniformity Measurement Locations (9 points)**

**Figure 3. Response Time Testing**

**Figure 4. Cross Modulation Test Description**

$$\text{Cross-Talk (\%)} = \left| \frac{Y_B - Y_A}{Y_A} \right| \times 100$$

Where:  $Y_A$  = Initial luminance of measured area ( $\text{cd/m}^2$ )

$Y_B$  = Subsequent luminance of measured area ( $\text{cd/m}^2$ )

The location measured will be exactly the same in both patterns

Figure 5. TFT-LCD Module Outline Dimensions (Front view)

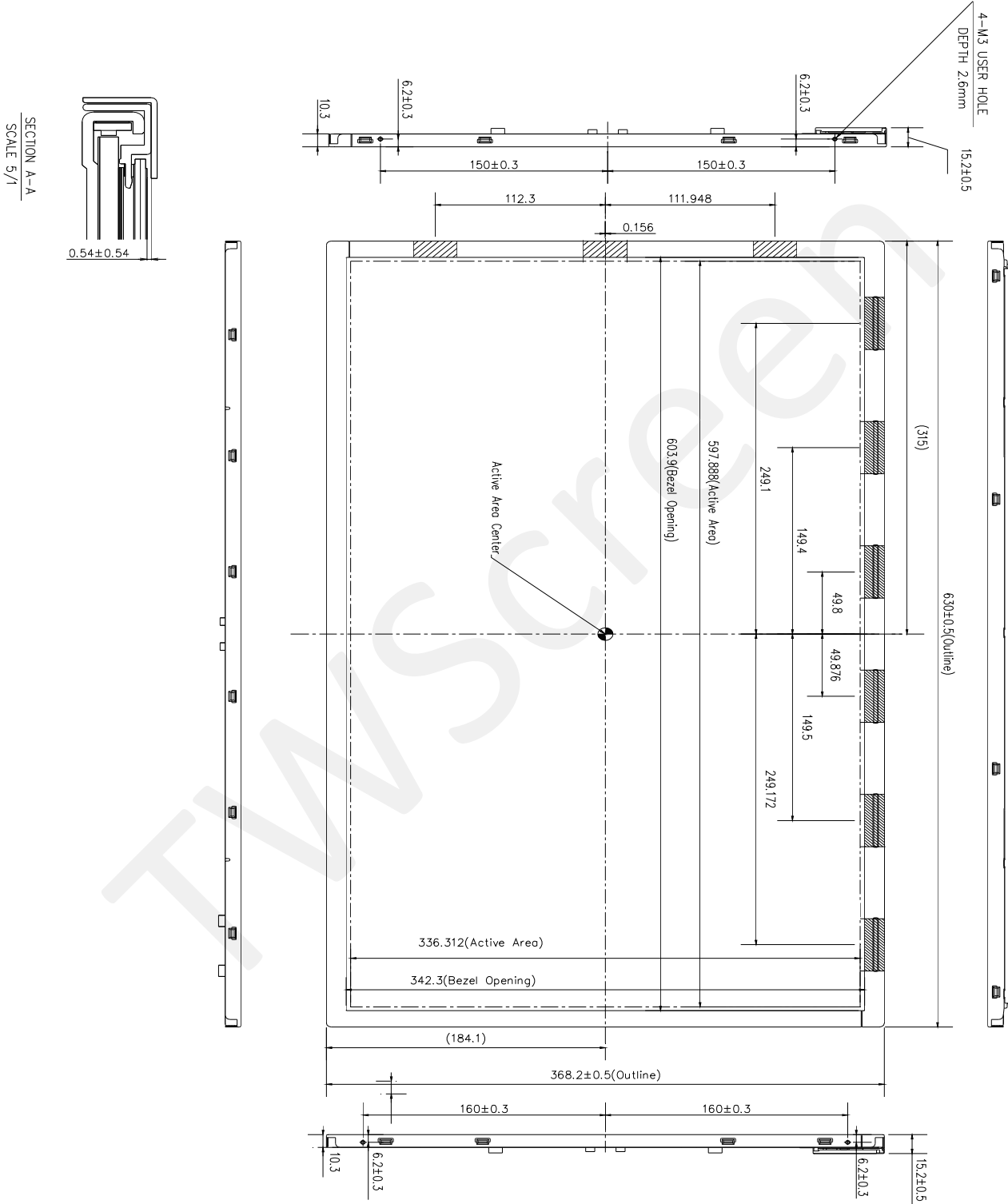

Figure 6. TFT-LCD Module Outline Dimensions (Rear view)

- NOTE
1. I/F CONNECTOR SPECIFICATION  
IS050-C51B-C39-S(UJU) or Equivalent
  2. LED CONNECTOR SPECIFICATION  
3707K-Q06N-08X (ENTRY) or Equivalent
  3. USER MOUNTING TORQUE SPEC : 3~4 kgf-cm

