



Technically
Superior
Uniquely Design
Beautifully Crafted
Outstanding Reliability
Supreme Quality
Affordable
Nippon Origin



致 辭

敬啟者：祝願貴公司事業日益繁榮昌盛。

對於各位平時惠顧壺三產品的深情厚意深表謝意。

壺三自1928年創立以來，一直從事以銼刀為主的手工切削工具的製造和銷售。

近年來被切削物呈多樣化並涉及到各個領域。壺三應市場需求，開發了切削性，耐久性和耐磨性能更為卓越的新產品。

托各位之福，壺三現隆重推出集新舊產品之大成的最新產品目錄，敬乞垂覽。

壺三今後仍將努力開發滿足客戶需求的產品，旨在通過產品成為客戶至上的公司。

務請多多惠顧壺三產品。

謹 啟

Dear Sirs,

We, TSUBOSAN, are acknowledge with many thanks for your long termed business relationship.

Since the foundation in 1928,

TSUBOSAN has continued to manufacture & supply "the EDGE TOOLS by hand",
which are representative of "STEEL FILES & RASPS".

HAND TOOLS like Steel Files were used by everybody in our long long human history.

Recently,

Work-Piece-Materials have been used variedly in covering the wide ranged industrial fields .

Therefore,while TSUBOSAN was catching up such needs of customers,

TSUBOSAN has developed New TOOLS that were supirior to
the sharp-ability,the durability and the resistance of facing of EDGE TOOLS.

TSUBOSAN hereby deliver our NEW CATALOGUE to you,
which shows up all TSUBOSAN products.

TSUBOSAN exactly hope this CATALOGUE to assist you
in your working & manufacturing process.

We remain with best regards.

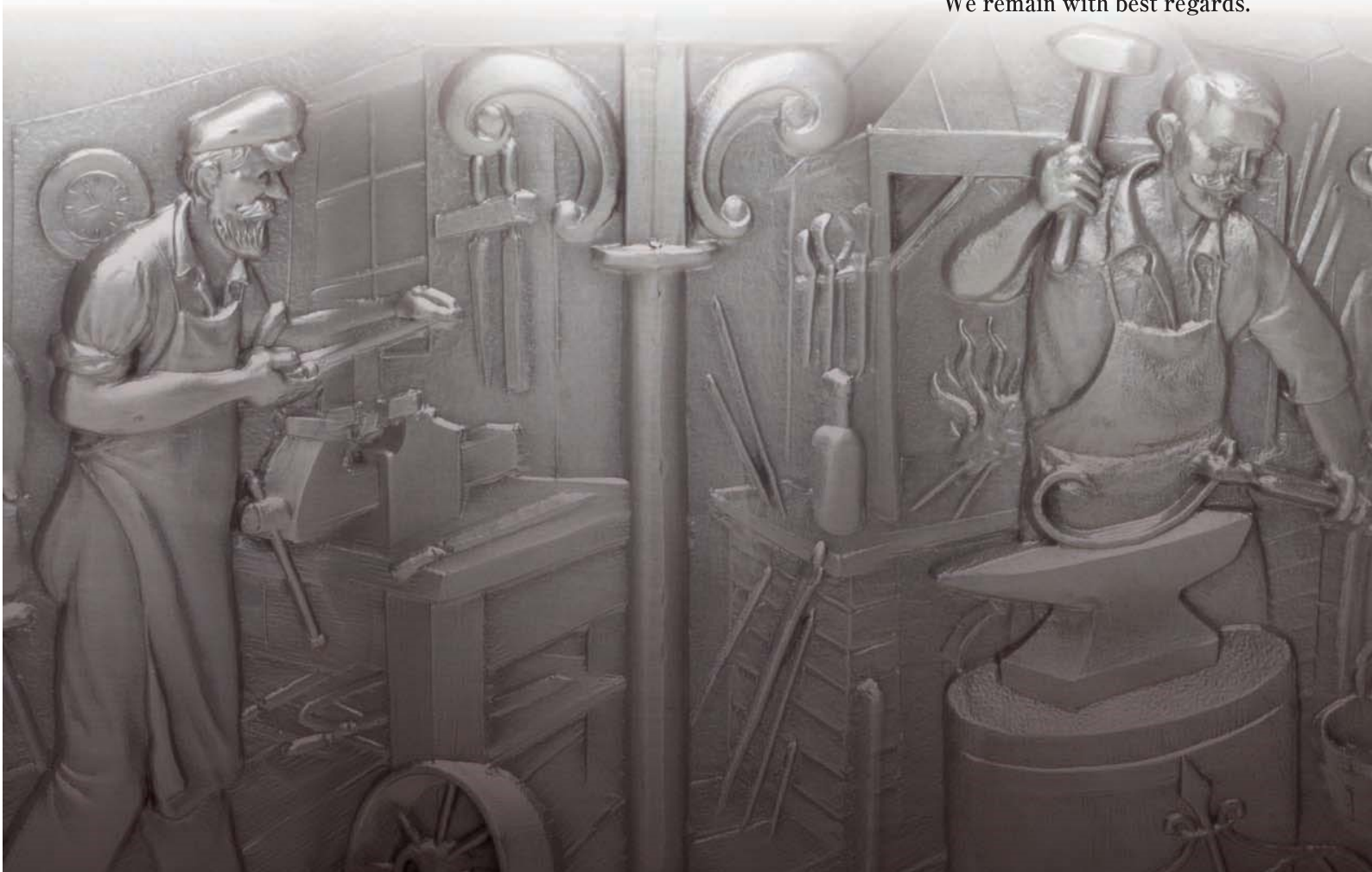

鋼銼製造工序

FILE PRODUCING PROCESS

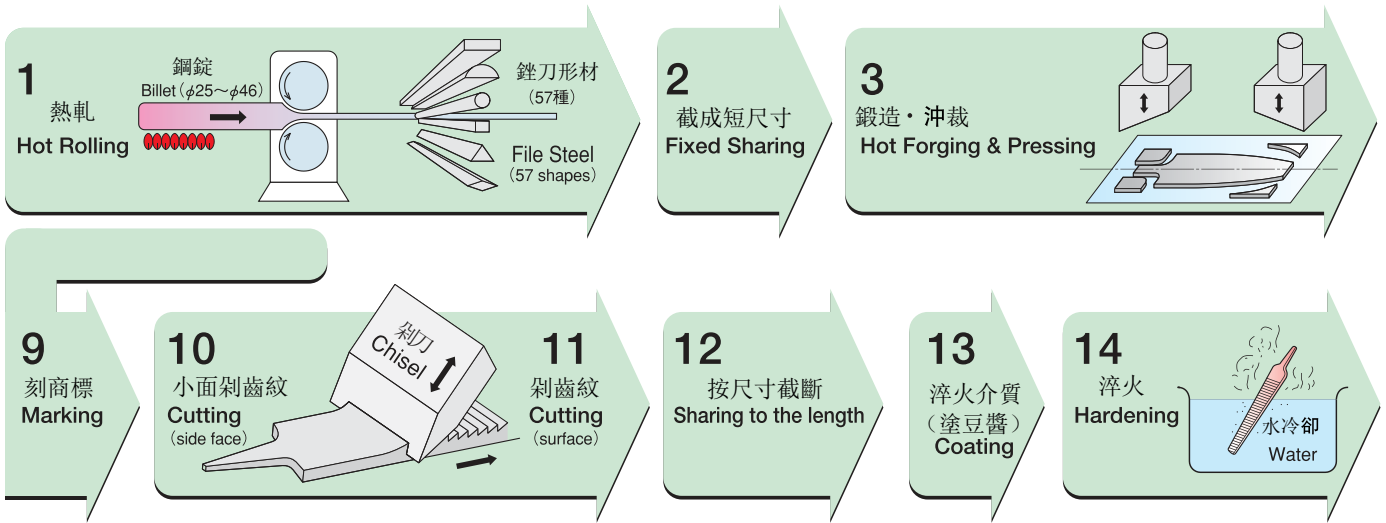

關於銼刀鋼材

FILE STEEL

鋼種類 JIS. Code G 4404	化學成分 (%) CHEMICAL COMPOSITION						熱處理 HEAT TREATMENT		淬火硬度 HARDNESS
	C	Si	Mn	P	S	Cr	退火 ANNEALING	淬火 HARDENING	
合金工具鋼 SKS-8	1.30~ 1.50	≤0.35	≤0.50	≤0.03	≤0.03	0.20~ 0.50	750~800°C 自然冷卻 Slow Cooling	780~820°C 水冷卻 Water Quenching	HRC ≥ 63 Hv ≥ 780
碳素工具鋼 SK-2	1.10~ 1.30	≤0.35	≤0.50	≤0.03	≤0.03	—	750~800°C 自然冷卻 Slow Cooling	760~820°C 水冷卻 Water Quenching	HRC ≥ 63 Hv ≥ 780

齒紋粗度

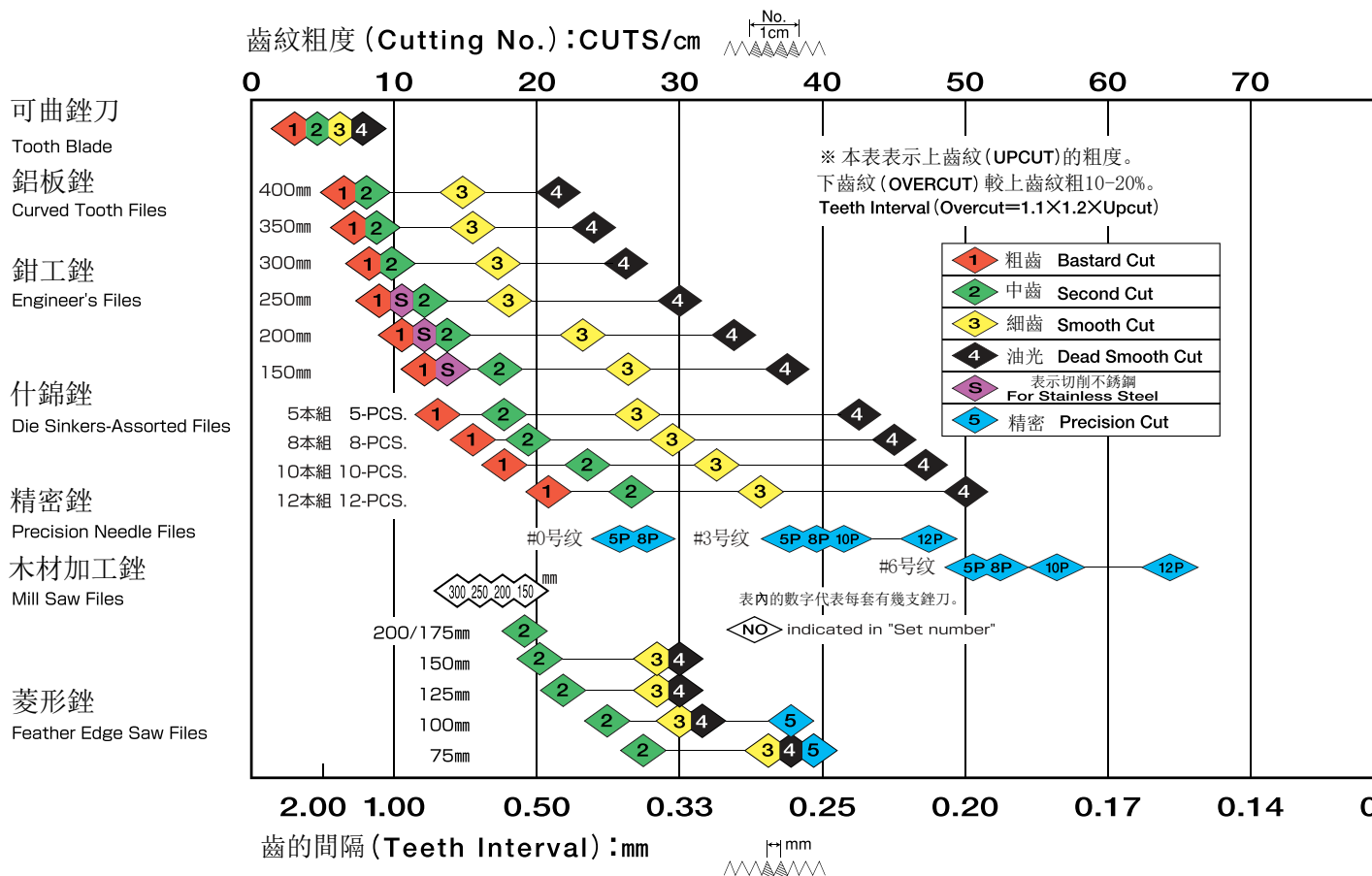



關於銼刀規格 FILE STANDARD

● 關於銼刀規格

依據 { JIS-B4703 鐵工銼
JIS-B4704 什錦銼
JIS-B4705 刀銼
JIS-B4706 木材加工銼 } 規定製造

Ref. JIS (Japanese Industrial Standard)
B4703, B4704, B4705, B4706



下齒紋相對上齒紋
粗10~20%。

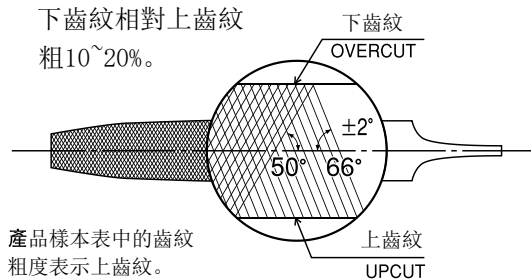

產品樣本表中的齒紋
粗度表示上齒紋。

鋼銼八題 ①

荊山 信行

對鋼銼開始有興趣後跑舊書店的次數便頻繁起來。

翻閱『正倉院目錄』時，發現在南倉的工匠工具和北倉的十合鞘禦刀子的說明處都有「錯」的漢字。這個字的訓讀似乎讀做銼。

根據漢和辭典的解釋，該字的音讀應讀作。單從字義上看，是有著縱，橫鋸齒狀的金屬銼刀。其中“昔”字是鋸齒狀重疊的意思。因此，「錯」字是在金屬上刻上重疊鋸齒狀線條便成為銼。順便提一下，「錯磨」應用在銼刀上便是使勁地磨的意思。

江戶時代的百科辭典『和漢三才圖會』裏在銼刀的項裏也引用了「錯子」的漢字。

若用漢字寫

據中國的古墓出土報告書『滿城漢墓挖掘報告』中記載，漢字有「銼」字。字義是竹短且呈鋸齒狀的金屬。與正倉院的銼刀「錯」字是同義。

在『銼刀企業名簿』裏，諸如壺○○鈔製作所等等都是使用「鈔」的漢字。而之前普遍都用「鑢」字。當然，當時沒有用這漢字。

兩個字均讀做銼刀。「鈔」又念作“たたら”。「鑢」也可念作“たたら”，但在『廣島縣誌』中極東鑢合資會社中的「鑢」便念作銼刀。可見，銼刀和たたら似乎又是親戚。這樣的話，以前用作銼刀的材料是用たたら制鐵製作的玉鋼。

除此之外，被念作銼刀的漢字，如「銼」，「鋼」，「鑢」，「銼」，「鋸」等出乎意料的有許多。

(廣島縣立西部工業技術中心主任研究員=吳市)

綠地帶 3.9.26 摘自中國新聞

80	90	100	110	120	130
K類型 #150			S類型 #200		
0.13	0.11	0.10	0.09	0.08	0.075

金剛石銼
Diamond Files

* 金剛石銼の場合，把砥粒の直徑表示齒紋の間隔。
參考下表

粒度號表示 Grid No.	金剛石砥粒の直徑 Diamond Grid Diameter
# 100	0.14 ~ 0.17mm
# 150	0.09 ~ 0.12mm
# 200	0.075 ~ 0.09mm
# 400	0.05 ~ 0.07mm
# 600	0.03 ~ 0.04mm
# 1000	0.01 ~ 0.02mm

目錄 (INDEX)

名稱 (NAME)	編號NO.	名稱	NAME	PAGE
鐵工銼 ENGINEER'S FILES 鐵 輕 S A	011~018	鉗工銼	ENGINEER'S FILES	7
	030	不銹鋼銼	FILES FOR STAINLESS	9
	040	單紋萬能銼	UNI-CUT FILES	9
	050	100mm鉗工銼	100mm ENGINEER'S FILES	10
	804	雙手銼	FILE WITH BOTH HANDS	10
	810	塑膠銼	FILES FOR PLASTICS	11
	820	五德萬能銼	FILES FOR FIVE DIFFERENT USES	11
	830	雕金銼	CHASING FILES	11
	900	木柄	WOODEN HANDLE	12
	901	塑膠柄	PLASTICS HANDLE	12
什錦銼 DIE SINKER'S-ASSORTED FILES 鐵 輕 S A	105~112	什錦銼	DIE SINKER'S-ASSORTED FILES	15
	131~133	專業銼	PRO-FILES	17
	140	單紋萬能銼	UNI-CUT FILES	18
	143	刃磨銼	SHARP CUT FILES	18
	145	薄平銼	THIN HAND FILES	18
技能競賽鑒定銼 FILES FOR CONTEST 鐵 輕 S A	070	鑒定銼套裝	SET	19
	075	鑒定銼-鉗工類	ENGINEER'S TYPE	20
	155	鑒定銼-什錦類	ASSORTED TYPE	20
	935	鑒定銼-其他	ACCESSORY	20
電鍍銼 COATING FILES 鐵 鋼 輕 S C A	610·620	快速切削銼	QUICK CUT FILES	21
	650·660	硬鉻銼-900	BRIGHT-900	22
	510	滲陶瓷手用銼	CERAMICS COATING FILES	23
	511	滲陶瓷機用銼	SUPER SAW (VC)	23
	520	鍍鈦機用銼	TIN SUPER HAND	24
	902	手柄	HANDLE (FOR TIN SUPER HAND)	24
精密銼 PRECISION NEEDLE FILES 鐵 輕 S A	305~312	精密銼	PRECISION NEEDLE FILES	25
	331	精密鐵匠銼	SUPER FINE ENGINEER'S FILES	25
	340	極細銼	VERY THIN HAND DITCH FILES	25
	353	線狀圓銼	LINE ROUND FILES	25
	370	彎曲銼	BENDABLE PRECISION NEEDLE	26
	358	火花塞專用銼	POINT FILES	26
	360	雕金銼	CHASING FILES	27
	365	齒科技工用銼	DENTAL FILES	27
金剛石銼 DIAMOND FILES 鋼 石 C S-G	411	S類型	S-TYPE	29
	421	K類型	K-TYPE	29
	426	金剛石平斜銼	TAPERED FORM	30
	427	金剛石薄平銼	THIN HAND FORM	30
	435	5" 金剛石銼	5"DIAMOND FILES	31
	430	200mm金剛石板銼	HAND 200mm(#200,#600)	31
	470	金剛石曲型銼	DIAMOND LAPPER	31
	445	金剛石菱形銼	DIA FEATHER EDGE SAW-FILES	31
	450	金剛石異型銼	DIAMOND CRAFTSMAN	32
	428	金剛石線狀圓銼	DIAMOND LINE-ROUND	32
	447	金剛石鏈鋸銼	DIA ROUND CHAIN SAW-FILES	32
	460	金剛石直圓銼	DIAMOND ROUND-TYPE	32
	440	竹柄金剛石銼刀	FLEX DIA(Bamboo Stick)	33
	442	可彎金剛石砂紙	FLEX DIAMOND SHEET	33
	490	金剛石砂紙	DIAMOND SHEET	33
	480	金剛石砂輪修正筆 (洗石筆)	DIAMOND DRESSER	34
	485	金剛石割磨片	DIA DISK SHARPENER	34
	484	金剛石打孔鑽	DIAMOND CORE DRILL	34
鋸型銼 SAW FILES 鋼 C	210	木材加工銼	MILL SAW FILES	37
	208	石材加工銼	ROUND CHAIN SAW FILES	37
	200	菱形銼	FEATHER EDGE SAW FILES	37
	201	刀刀銼	FEATHER EDGE:FINISHING	37
	220	細長銼	SLIM FILES	38
	211	農鏟銼	FARMER'S FILES	38
波形銼 CURVED TOOTH FILES 鐵 輕 木 塑 橡膠 石膏 S A W P R PB	240	鋁板銼	CURVED TOOTH FILES	39
	245	木工雕刻銼	WOODCRAFT FILES	39
	242	軟性材料銼	SOFT WORK FILES	40
	255	可曲銼刀	CURVED TOOTH BLADES	41
	910	柄 (夾具)	HOLDER	41

名稱 (NAME)	編號 NO.	名稱	NAME	PAGE
粗銼 RASPS 鐵 木 橡膠 鉛 S W R L	270	木工銼	FILE RASPS	43
	276	軟材用銼	RASPS	43
	280	馬蹄銼	BOARD RASPS	44
	272	鉛木工銼	CABINET FILES	44
	279	鞋銼	SHOE RASPS	44
修整銼 MODIFICATION FILES 修整 鋼 石 M C S·G	257	邊緣修整銼	EDGE TRIMMER	45
	800	螺紋修整銼	SCREW THREADS FILES	46
	350	超薄平銼	VERY THIN HAND DITCH FILES	47
	380	吉他修整銼	GUITAR FILES	47
	397	修邊刀	TRIMMING KNIFE	47
	850	牙刷柄油石	HAND LAPPER	48
	860	硬度測定銼	HARDNESS TESTER	49
電動・AIR工具用銼 FILES FOR MACHINE 鐵 鋼 輕 石 S C A S·G	720	旋轉銼	ROTARY FILES	51
	481	金剛石磨頭	DIAMOND-BIT	52
	511	滲陶瓷機用銼	SUPER SAW (VC)	53
	520	鍍鈦機用銼	TIN SUPER HAND	53
	381	機用銼	SUPER HAND	54
	其他 OTHERS	880	滑雪銼	SKI FILES
446		禮品 & 業餘愛好	GIFT & HOBBY	56
970		銼用刷子	BRUSH FOR FILES	56
940		皮革尖鑽	AWL	56
835		磨刀棒	SHARPENING STEEL	58
999		特殊加工銼	SPECIAL ORDER	59
外國制銼刀 OVERSEAS COMPETITORS	SWISS	瑞士	Vallorbe	61
	USA	美國	Nicholson	65
	GERMANY	德國	PFERD	66
	FRANCE	法國	pascal	66
	USA	美國	MITCHELL	66
附錄 SUPPLEMENT		實際尺寸圖	REAL DIMENSIONS	67
		銼刀斷面寬度一覽表	STEEL FILES SECTION TABLE	69
		鋼材	HOT ROLLING STEEL BAR	71
		剝齒機械	CUTTING MACHINE	72

記號說明
EXPLANATION OF MARKS

	公稱尺寸 Sized Length		BOX pcs 內箱 Inner Box
	柄部尺寸 Tang Length		CARTON pcs 外箱 Packing Case
	重量 Weight		

鐵	S	鐵・不銹鋼 STEEL・STAINLESS STEEL
鋼	C	硬質鐵金屬 CARBONIZED STEEL
輕	A	鋁・銅・貴金屬 Al・Cu・PRECIOUS METAL
木	W	木頭 WOOD
塑膠	P	塑膠 PLASTICS
橡膠	R	橡膠・皮革 RUBBER・LEATHER
石膏	PB	石膏板 PLASTER BOARD
鉛	L	鉛 LEAD
石	S·G	石・玻璃 STONE・GLASS
修整	M	修整用 MODIFICATION

看項目編號方法
EXPLANATION OF ITEM NO.

形狀		尺寸		齒紋種類				
套	SeT	150mm	150		複齒	單齒	波形齒	
扁	Hlra	200mm	200	粗齒(Ba.)	01	11	61	
半圓	HAnmaru	250mm	250	中齒(2nd.)	02	12	62	
圓	MAru	300mm	300	細齒(Sm.)	03	13	63	
方	KAKu	350mm	350	油光(D.Sm.)	04	—	—	
三角	SAnkaku	400mm	400	難切削材專用齒	05	—	—	
梯形	SInogi	5本組	005	單紋齒	—	15	—	
尖扁	SakiHoso	8本組	008	精修銼	16	—	—	
橢圓	DaEn	10本組	010	鋸形銼	木工	—	20	
刀口	KatanaHa	12本組	012		兩刃	—	22・23	—
蛤形	HamaGuri			鏈鋸	—	24・25	—	
雙半圓	RyoKo			粗紋銼	木工	—	28	
金剛石	TD・D				鉛工	—	40	—
撓形	FX			鉛木工	—	30	—	
馬蹄銼	BD			精密銼	#6號齒	56	90	
旋轉銼	RF				#3號齒	53	—	—
木柄	ME			金剛石銼	#100	00	—	
塑膠柄	PE				#150	10	—	—
夾具	HO				#200	20	—	—
					#300	30	—	—
					#400	40	—	—
				#600	60	—	—	

鉗工銼 ENGINEER'S FILES

鉗工銼

011
扁
HAND

012
半圓
HALF ROUND

013
圓
ROUND

014
方
SQUARE

015
三角
TRIANGULAR

018
橢圓
OVAL

017
尖扁
FLAT

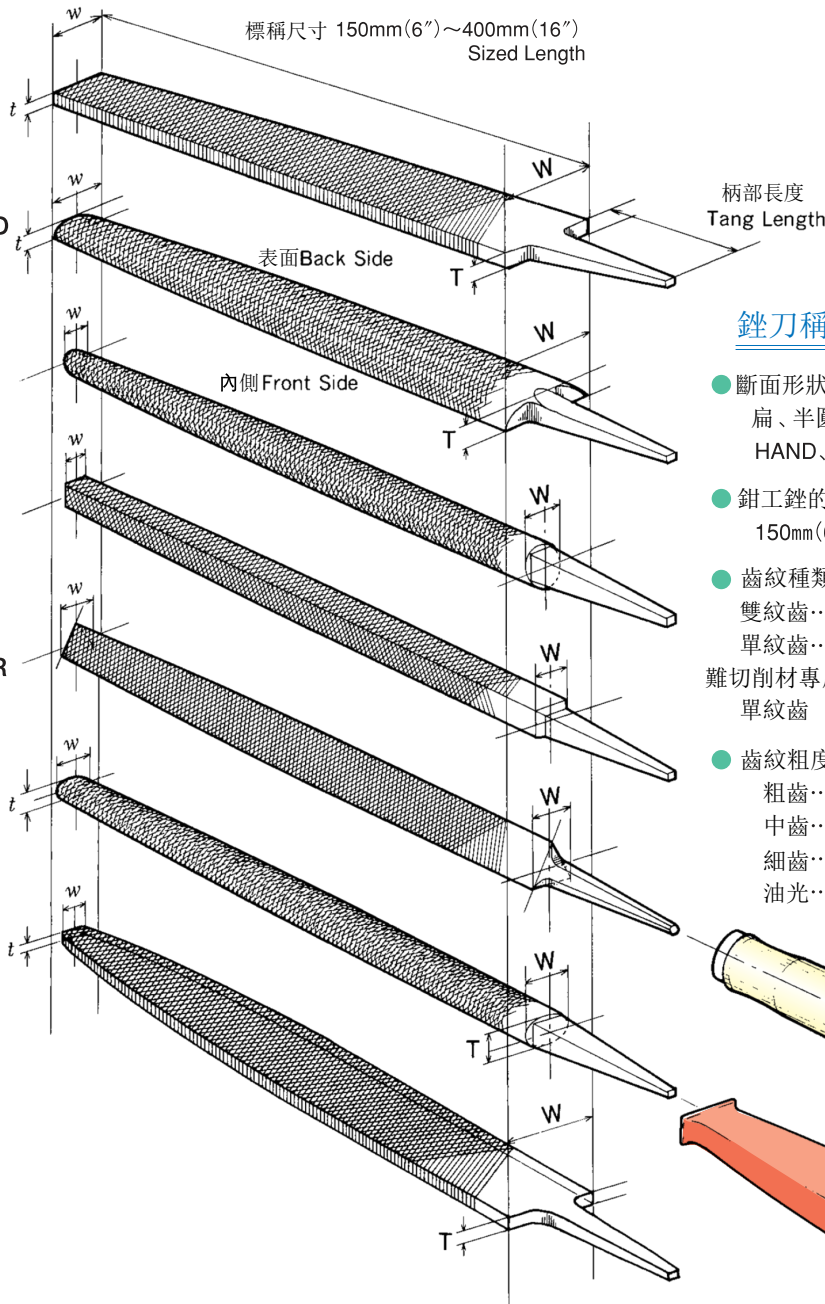

銼刀稱呼方法

- 斷面形狀 Shapes
扁、半圓、圓等
HAND、HALF ROUND、ROUND、etc.
- 鉗工銼的標稱尺寸 Sized Length
150mm(6")~400mm(16")
- 齒紋種類 Cutting Type
雙紋齒.....W-cut (Double)
單紋齒.....S-cut (Single)
難切削材專用齒...Tri-cut
單紋齒...Uni-cut
- 齒紋粗度 Cutting No.
粗齒.....Bastard
中齒.....Second
細齒.....Smooth
油光.....Dead Smooth

900
木柄
Wooden Handle

901
塑料柄
Plastics Handle

齒紋粗度表 CUTTING No. TABLE $\pm 10\%$ allowance

INCH		mm		荒目 cuts/cm	中目 cuts/cm	細目 cuts/cm	油目 cuts/cm	難切削材專用齒 cuts/cm	單紋齒 cuts/cm			
				Bastard	Second	Smooth	Dead Smooth	Tri-cut	Uni-cut			
6	150		12		16		25		38		13	—
8	200		10		14		22		34		12	
10	250		9		12		19		30		11	—
12	300		8		10		17		26	(10)	—	—
14	350		7		9		15		23	—	—	—
16	400		6		8		14	—	—	—	—	—

規格表 STANDARD TABLE

011

扁 HAND	INCH		mm		W × T mm		w × t mm		mm	kg-doz	BOX pcs	CARTON pcs	ITEM NO.
	6	8	150	200	16 × 4	21 × 5	14 × 2.5	19 × 3					
	10	12	250	300	25 × 6	30 × 7	22 × 4	26 × 5	60	3.22	6	120	HI 250**
	14	16	350	400	34 × 7.5	36 × 8.5	30 × 5.5	32 × 6.5	80	8.00	6	60	HI 300**
									90	11.24	6	24	HI 400**

012

半圓 HALF ROUND	INCH		mm		W × T mm		w × t mm		mm	kg-doz	BOX pcs	CARTON pcs	ITEM NO.
	6	8	150	200	16 × 4.5	21 × 6	8.5 × 3.3	12 × 4.3					
	10	12	250	300	25 × 7	30 × 8.5	15 × 5.5	17 × 6.5	60	3.00	6	120	HA 250**
	14	16	350	400	34 × 10	36 × 11	19 × 6.8	20 × 7	80	8.12	6	60	HA 350**
									90	10.48	6	24	HA 400**

013

圓 ROUND	INCH		mm		W mm	w mm	mm	kg-doz	BOX pcs	CARTON pcs	ITEM NO.
	6	8	150	200							
	10	12	250	300	φ 10	φ 5.2	60	1.88	6	120	MA 250**
	14	16	350	400	φ 15	φ 8	80	5.62	6	60	MA 350**
					φ 18	φ 10	90	9.60	6	24	MA 400**

014

方 SQUARE	INCH		mm		W mm	w mm	mm	kg-doz	BOX pcs	CARTON pcs	ITEM NO.
	6	8	150	200							
	10	12	250	300	10	5.2	60	2.26	6	120	KA 250**
	14	16	350	400	15	8.5	80	7.08	6	60	KA 350**
					18	11	90	11.40	6	24	KA 400**

015

三角 TRI-ANGULAR	INCH		mm		W × T mm		w × t mm		mm	kg-doz	BOX pcs	CARTON pcs	ITEM NO.
	6	8	150	200	12	15	7	8.5					
	10	12	250	300	17	10	60	3.24	6	120	SA 250**		
	14	16	350	400	22	13	80	7.14	6	60	SA 350**		
	(16)	(20)	(400)	(450)	(25)	(14)	(90)	(10.24)	(6)	(24)	(SA 400**)		

018

橢圓 OVAL	INCH		mm		W × T mm		w × t mm		mm	kg-doz	BOX pcs	CARTON pcs	ITEM NO.
	6	8	150	200	10 × 5.5	12 × 8	6.5 × 3.6	7.8 × 5.2					
	10	12	250	300	15 × 10	18 × 12	60	2.20	6	120	DE 250**		
	14	16	350	400	20 × 15	24 × 18	80	6.35	6	60	DE 350**		

017

尖扁 FLAT	INCH		mm		W × T mm		w × t mm		mm	kg-doz	BOX pcs	CARTON pcs	ITEM NO.
	6	8	150	200	16 × 4	21 × 4.5	12 × 2.5	17 × 3					
	10	12	250	300	25 × 5.5	30 × 6.5	20 × 4	24 × 5	60	2.72	6	120	SH 250**
	14	16	350	400	34 × 7.5	36 × 8.5	28 × 5.5	30 × 6.5	80	7.60	6	60	SH 350**
									90	10.90	6	24	SH 400**



手柄

ITEM No. ** assorted

900

TYPE	外形尺寸 Size mm	內孔直徑 Hole Size	kg-box	BOX pcs	ITEM NO.	粗齒	中齒	細齒	油光	雙切專用齒	單紋齒	
						Bastard	Second	Smooth	Dead Smooth	Tri-cut	Uni-cut	
木柄 Wooden Handle	小(S)	φ 23 × 100	Flexible	1.2	50	ME 900S	01	02	03	04	05	15
	中(M)	φ 25 × 115		1.6	50	ME 900M	11	12	13	-	-	-
	大(L)	φ 27 × 135		1.3	30	ME 900L						
	軟(L)	φ 30 × 150		0.7	10	ME 900LL						
塑膠柄 Plastics Handle	小(S)	30 × 1.7 × 105	φ 4.7	1.3	50	PE 901S						
	中(M)		φ 6.3			PE 901M						
	大(L)		φ 7.8			PE 901L						

<ITEM No.例> 鉗工銼扁150mm中齒 : HI15002

<ITEM No.ex> ENGINEER'S FILE HAND 150mm Second

: HI15002

不銹鋼（切削用）銼 FILES FOR STAINLESS STEEL

030

鉗工銼

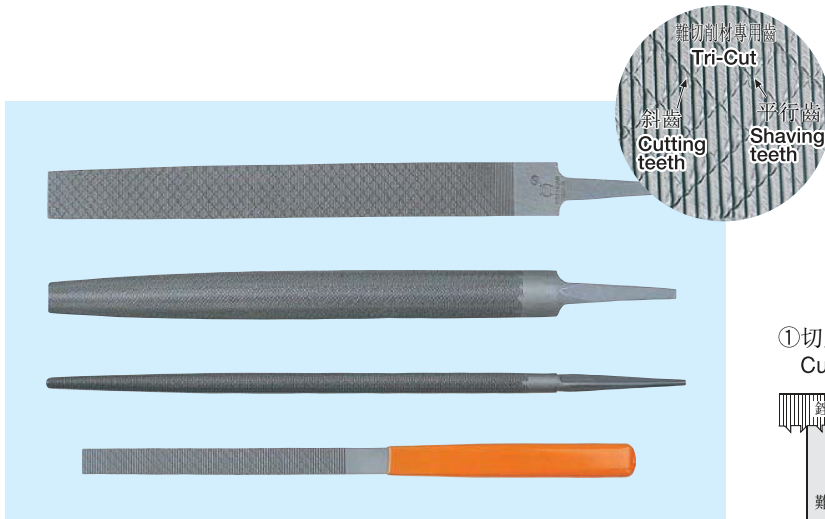

■特長

- 使用特殊高級鋼材SKS-8。
- 用斜齒切入難切削材料後，再用平行齒平穩銼削。
- 適用於不銹鋼等難切削鋼材。

■Material : SKS-8(JIS)

■Use : For stainless steel

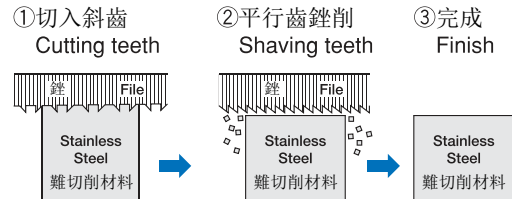

規格表 STANDARD TABLE

INCH		mm		BOX pcs	扁 HAND			半圓 HALF ROUND			圓 ROUND		
					W × T mm	kg-doz	ITEM NO.	W × T mm	kg-doz	ITEM NO.	W mm	kg-doz	ITEM NO.
6	150	40	6	16 × 4	0.92	HI 15005	16 × 5	0.88	HA 15005	φ 6	0.52	MA 15005	
8	200	50	6	21 × 5	1.94	HI 20005	21 × 6	1.88	HA 20005	φ 8	1.10	MA 20005	
10	250	60	6	25 × 6	3.36	HI 25005	25 × 7	3.16	HA 25005	φ 10	2.04	MA 25005	

齒紋粗度表 CUTTING No. TABLE

5支裝 5-PCS 扁 HAND	BOX pcs	W × T mm	kg-doz	ITEM NO.
215	25	11 × 3.5	1.48	HI 00505

150mm cuts /cm	200mm cuts /cm	250mm cuts /cm	5支組 cuts /cm
13	12	11	10

單紋齒萬能銼 UNI-CUT FILES

040

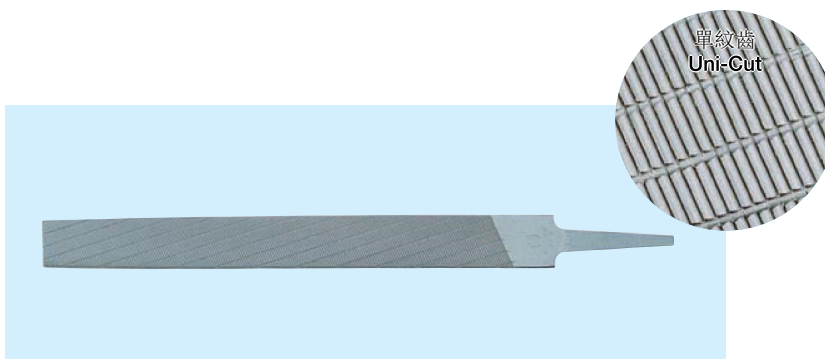

■特長

- 使用特殊高級鋼材SKS-8。
- 在單齒上開排屑槽。
- 適用於壓鑄件，輕合金，塑膠等被切削物。

■Material : SKS-8 (JIS)

■Use : For steel, soft metals.

Fine finishing by single-cut teeth, and smooth filing by chip breakers.

規格表 STANDARD TABLE

INCH	mm	W × T mm	kg-doz	ITEM NO.
8	200	21 × 5	1.72	HI 20015

齒紋粗度 CUTTING No. TABLE

200mm cuts /cm	5支組 cuts /cm
10	11

100mm (4") 鉗工銼

100mm ENGINEER'S FILES

050



■特長

- 配有木制手柄的使用方便的銼刀。
- 齒紋為中齒。

■Use : With a wooden handle to each steel file.
Second cut.

規格表 STANDARD TABLE

A mm		套 SET	扁 HAND W × T mm	半圓 HALF ROUND W × T mm	圓 ROUND φ4
100A	90B	—	10 × 4	11 × 4	φ4
No./1set		3 (each1)	1	1	1
kg-1set		0.1	0.04	0.04	0.02
ITEM No.		ST 10002	HI 10002	HA 10002	MA 10002

雙手銼

FILE WITH BOTH HANDS

804



■特長

- 適用於大平面的加工。是銼刀廠使用的銼刀。

■用途

- 去除切削傷痕，平整平面。
- 噴砂後的平面整理。
- ➡按箭頭方向銼削。

■Use : This steel file has 2 different roughness of Bastard and Smooth cut on it's next surface, and used by both hands.

Then it's resulted that the work surface can be finished flatly without uneven roundness.
It's Direction ➡only can be cut.

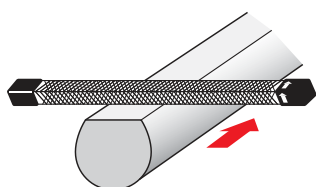

●圓形材料的平面！
Facing the round bar.

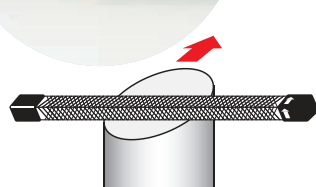

●端面的精加工！
Facing the edge side.

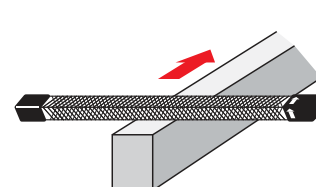

●長材料的平面加工！
Facing the front side.

規格表 STANDARD TABLE

DIMEN- SION	L			W mm	BOX pcs	kg-do2	ITEM NO.
	L	ℓ	A mm				
100mm	260	100	80	8	6	2.6	KA 100WH
150mm	330	150	90	10	6	4.4	KA 150WH
200mm	400	200	100	12	6	7.0	KA 200WH

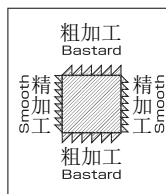

●如斷面所示，在一支銼刀上相鄰的分別是粗齒紋和細齒紋，可應用於粗加工和精加工。

●Rough and finished filing can be worked by only one steel file.



規格表 STANDARD TABLE

DIMEN- SION	L			W × T mm	BOX pcs	kg-do2	ITEM NO.
	L	A	B mm				
300mm	250	70	135	30 × 5	6	5.0	HI 300WH



齒紋放大圖

塑膠銼 FILES FOR PLASTIC

810

鉗工銼



- 用途
- 適用於塑膠製品的加工。

■Use : For Plastic.

規格表 STANDARD TABLE

DIMENSION			BOX		ITEM NO.
TYPE	mm	W × T mm	pcs	kg-doz	
P ₁	235	20 × 3	12	1.52	HIP 1**
P ₂	235	15 × 3	12	0.99	HIP 2**
P ₃	220	10 × 3	12	0.82	HIP 3**

ITEM No. ** assorted

	粗齒 Bastard	中齒 Second	細齒 Smooth
**	11	12	13

五德萬能銼 FILES FOR FIVE DIFFERENT USES

820



- 用途
- 表面靜電噴塗，防銹，壽命長。
 - 適用於金屬，木工，塑膠等。

■Use : For Metal, Wood, Plastic, etc.

規格表 STANDARD TABLE

			ITEM NO.
mm	W × T mm	kg-doz	
220	21 × 5	2.0	HIB 220

雕刻金屬銼 CHASING FILES

830

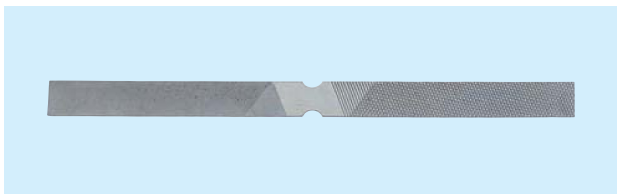

- 用途
- 用於粗加工。適用於容易積屑的被切削物的切削。如貴金屬，銅，鋁，橡膠，固狀黃蠟等。

■Use : For ART work of Precious Metals, Copper, Aluminum, Rubber, Solid Wax, etc.

規格表 STANDARD TABLE

			ITEM NO.	
mm	W × T mm	kg-1p		
240L	110ℓ	16 × 3	0.1	RTHI 240

木柄 WOODEN HANDLE

900

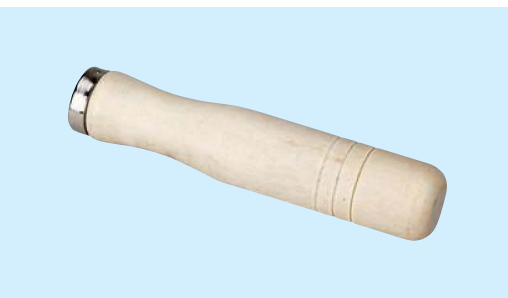

白木類型 WOODEN HANDLE

TYPE		銼刀適應尺寸 mm File-Length		kg-box	BOX pcs	ITEM NO.	
特小	SS	90L	φ 13A	≤100mm	1.0	150	ME 900SS
小	S	100L	φ 23A	150mm	1.2	50	ME 900S
中	M	115L	φ 25A	200mm	1.6	50	ME 900M
大	L	135L	φ 27A	250mm	1.3	30	ME 900L
特大	LL	150L	φ 30A	≥300mm	0.7	10	ME 900LL

■一般使用於廉價的木柄。



樺木類型 ZELKOVA WOODEN HANDLE

TYPE		銼刀適應尺寸 mm File-Length		kg-box	BOX pcs	ITEM NO.	
中	M	120L	φ 25A	≤200mm	1.9	30	KE 900M
大	L	140L	φ 30A	≥250mm	2.0	50	KE 900L

■樺木制木柄有高級感。
柄部塗清漆，不易粘污。



螺紋類型 SCREW INLAID WOODEN HANDLE

TYPE		銼刀適應尺寸 mm File-Length		kg-box	BOX pcs	ITEM NO.	
小	S	115L	φ 32A	≤250mm	0.6	10	NE 900S
大	L	125L	φ 35A	≥300mm	0.8	10	NE 900L

■與銼刀柄部緊密固定後提高操作性。

塑柄 PLASTICS HANDLE

901



螺紋類型 SCREW INLAID PLASTIC HANDLE

TYPE		銼刀適應尺寸 mm File-Length		kg-box	BOX pcs	ITEM NO.	
小	S	95L	φ 28A	≤200mm	1.0	10	NE 901S
中	M	110L	φ 31A	250mm	1.3	10	NE 901M
大	L	120L	φ 34A	≥300mm	1.8	10	NE 901L

■與銼刀柄部緊密固定後提高操作性。

製作例



根據尺寸，形狀等用途，能製作獨創的手柄。

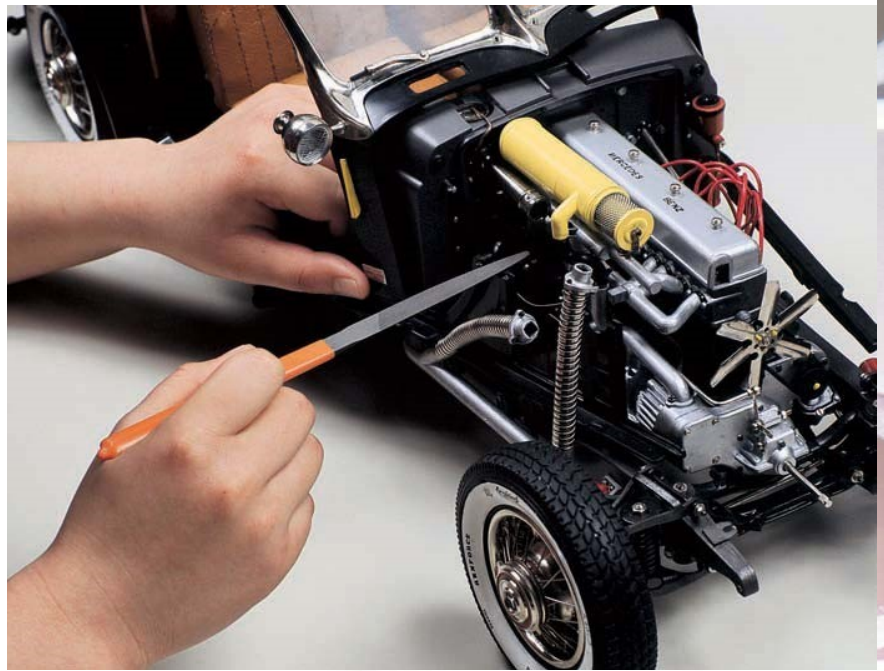

什錦銼 DIE SINKER'S-ASSORTED FILES

齒紋粗度識別 ●粗齒：紅 ●中齒：綠
 塑膠柄頂部顏色 ●細齒：黃 ●油光：黑

Orange colored HANDLE (vinyl chloride) with "END-CAP."

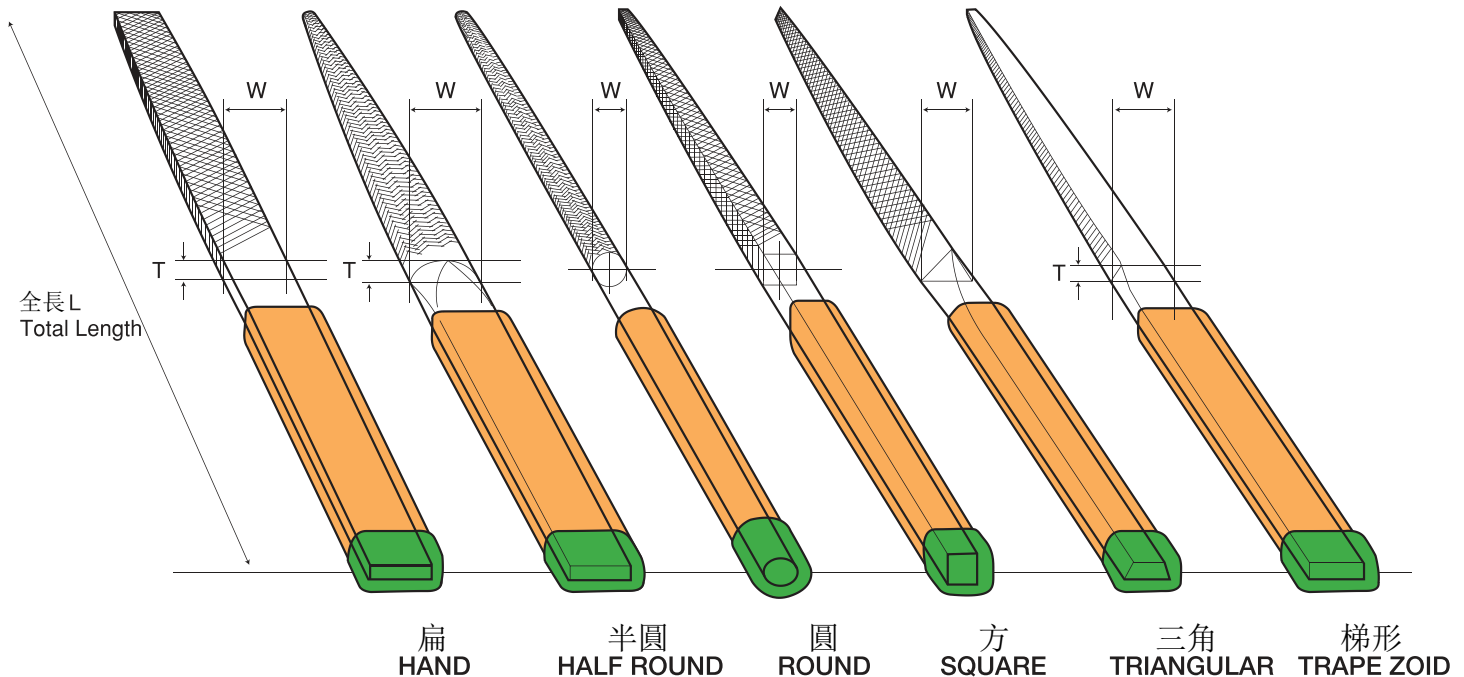

規格表 STANDARD TABLE

DIMENSION	L	套裝 SET	扁	半圓	圓	方	三角	梯形
			HAND	HALF ROUND	ROUND	SQUARE	TRIANGULAR	TRAPEZOID
TYPE	l mm ± 3		$W \times T$ mm	$W \times T$ mm	ϕ mm	W mm	W mm	$W \times T$ mm
105 5支裝 5-PCS	215L 110 l	—	11 × 3.5	12 × 3.8	φ5.5	5.5	9.0	(12) × (3.5)
	kg-25pcs	1.38	1.48	1.43	1.13	1.30	1.44	1.50
	No./1set	5(each 1)	5	5	5	5	5	(5)
	ITEM No.	ST 005**	HI 005**	HA 005**	MA 005**	KA 005**	SA 005**	SI 005**
108 8支裝 8-PCS	200L 100 l	—	9 × 3.0	9.5 × 3.0	φ4.3	4.3	7.5	9.5 × 3.0
	kg-40pcs	1.51	1.54	1.62	1.06	1.24	1.62	1.64
	No./1set	8(each 1)	8	8	8	8	8	8
	ITEM No.	ST 008**	HI 008**	HA 008**	MA 008**	KA 008**	SA 008**	SI 008**
110 10支裝 10-PCS	185L 85 l	—	7 × 2.5	7.3 × 2.5	φ3.2	3.2	6.0	7.3 × 2.5
	kg-50pcs	1.22	1.37	1.27	0.73	0.79	1.37	1.30
	No./1set	10(each 1)	10	10	10	10	10	10
	ITEM No.	ST 010**	HI 010**	HA 010**	MA 010**	KA 010**	SA 010**	SI 010**
112 12支裝 12-PCS	170L 70 l	—	4 × 2.0	4.2 × 2.0	φ2.5	2.5	4.0	4.2 × 2.0
	kg-60pcs	0.72	0.78	0.75	0.59	0.60	0.70	0.78
	No./1set	12(each 1)	12	12	12	12	12	12
	ITEM No.	ST 012**	HI 012**	HA 012**	MA 012**	KA 012**	SA 012**	SI 012**

ITEM No. ** assorted

	粗齒 Bastard	中齒 Second	細齒 Smooth	油光 Dead Smooth
雙線齒 W-cut	01	02	03	04
單線齒 S-cut	11	12	13	—

(ITEM No.例)

什錦銼5支裝扁中齒：HI 00502

(ITEM No.ex)

5-PCS HAND Second：HI 00502

齒紋粗度表 CUTTING No.TABLE

$\frac{No.}{1cm}$ $\pm 10\%$ allowance

TYPE	粗齒 Bastard	中齒 Second	細齒 Smooth	油光 Dead Smooth
5支裝 5-PCS	13 cuts/cm	17 cuts/cm	27 cuts/cm	40 cuts/cm
8支裝 8-PCS	15 cuts/cm	20 cuts/cm	30 cuts/cm	42 cuts/cm
10支裝 10-PCS	17 cuts/cm	23 cuts/cm	32 cuts/cm	44 cuts/cm
12支裝 12-PCS	20 cuts/cm	26 cuts/cm	35 cuts/cm	50 cuts/cm

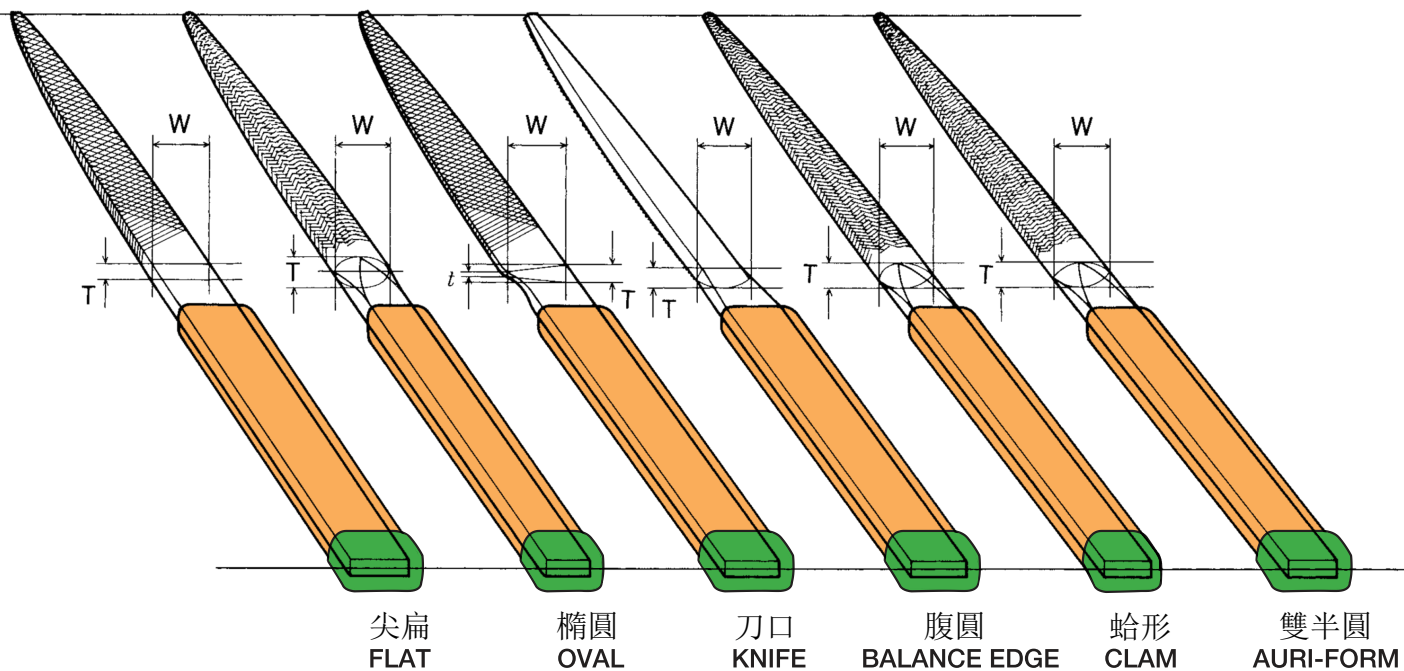

尖扁 FLAT	橢圓 OVAL	刀口 KNIFE	腹圓 BALANCE EDGE	蛤形 CLAM	雙半圓 AURI-FORM	每箱數量 No./BOX
W × T mm	W × T mm	W × T × i mm	W × T mm	W × T mm	W × T mm	BOX COLOR
(11) × (3.5)	(11) × (6.5)	(13) × (3.5) × (2.0)	(12) × (3.5)			BOX 25 pcs
1.50	1.80	1.48	1.48			CARTON 600 pcs
(5)	(5)	(5)	(5)			
SH 005 **	DE 005 **	KH 005 **	HM 005 **			BOX 40 pcs
9 × 3.0	9 × 4.5	(11) × (3.0) × (1.5)	(9.5) × (3.0)			CARTON 800 pcs
1.40	1.62	1.60	1.62			
8	8	(8)	(8)			BOX 50 pcs
SH 008 **	DE 008 **	KH 008 **	HM 008 **			CARTON 1000 pcs
7 × 2.5	7 × 3.4	8.2 × 2.5 × 1.0	7.3 × 2.5			
1.32	1.24	1.20	1.30			BOX 60 pcs
10	10	10	10			CARTON 1200 pcs
SH 010 **	DE 010 **	KH 010 **	HM 010 **			
4 × 2.0	4 × 2.5	4.5 × 2.0 × 1.0	4.2 × 2.0	4.2 × 2.2	4.0 × 2.2	BOX 60 pcs
0.76	0.82	0.72	0.70	0.78	0.82	CARTON 1200 pcs
12	12	12	12	12	12	
SH 012 **	DE 012 **	KH 012 **	HM 012 **	HG 012 **	RK 012 **	



- 粗齒 Bastard Cut 1
- 中齒 2nd. Cut 2
- 細齒 Smooth Cut 3
- 油光 D. Smooth Cut 4

銼刀八題 ②

荊山 信行

從古墓中出土的鐵器，因其幾乎被銹蝕覆蓋，表面特性往往不得而知。很多人認為「在國內出土的東西中，沒有被確實證明是銼刀的東西」。

而在國內出土的唯一類似銼刀的物件，在倉敷市的倉敷考古館有展示。

和這件物品同時出土的還有總社市西阿曾的隨庵古墓（五世紀後葉）中的鐵鉗，鐵銼，鐵鏈，磨刀石等。報告書中這樣記載。「該物件外觀全長有34.5厘米，厘米，柄部6厘米並伴有木柄的痕跡。銼身寬度為3厘米，厚度為5厘米，呈短帳冊形。尖端及兩側沒有刃。貌似成品但用途不明，或者根本不是銼刀。因該物品鏽跡斑斑，故無法判斷為何物」。

既然是與鍛造工具和磨刀石一起出土的物件，被認為是銼刀的話也有其一定的合理性吧。

設想一下製作刃物（鐵器）的工序吧。先將鍛件鍛造成大致形狀後用銼刀進行修整，最後用砂輪研磨後完成。試想，若在作業過程中省去銼刀修整這道工序而直接用砂輪研磨加工的話，既費大量時間，並且也非常不合理。所以在用砂輪

馬齒的形狀

（磨刀石）研磨加工完成前銼刀作業是必不可少的。

在具有五千年歷史，冶金工業技術名列前茅的中國出土了四支銼刀。

在河北省的滿城漢墓（BC113年）中出土的銼刀的報告中有以下記載。

「細長形狀，一端破損。單面的近一半部分刻有橫平面的銼齒，1厘米中有六個齒。類似於現在的『馬齒形銼』，屬於木銼類型。殘剩部分長度為20.4厘米，寬度為1厘米，厚度則為0.3-0.5厘米」。

這與日本『和漢三才圖會』出土的燕岐鏹非常相似。在中國表現為馬齒形狀，而在日本則被形容為石段的燕岐。

（廣島縣立西部工業技術中心主任研究員=吳市）

綠地帶 3.9.27 摘自中國新聞

專業銼 PRO-FILES

131 132 133

131

舟型 SHIP-type



132

曲型 CRANK-type



133

直尺型 STRAIGHT-type



■ 供專業工匠使用的銼刀。
For the "CRAFTSMAN"

■ Material : SKS-8 (JIS)

■ 專業銼一套5支裝。

規格表 STANDARD TABLE

131
舟型
SHIP
type

DIMEN- SION	L			套裝 SET	扁 HAND W × T mm	半圓 HALF ROUND W × T mm	圓 ROUND W mm	方 SQUARE W mm	三角 TRIANGULAR W mm	每箱數量 No./BOX	
	TYPE	mm	mm								mm
5支裝 5-PCS	215L 27A 200R	—			0.29	0.31	0.29	0.22	0.25	0.29	BOX 5 pcs CARTON 100 pcs
	kg-5pcs	0.29			0.31	0.29	0.22	0.25	0.29		
	No./1set	5 (each 1)			5	5	5	5	5		
	ITEM No.	STS 05 * *			HIS 05 * *	HAS 05 * *	MAS 05 * *	KAS 05 * *	SAS 05 * *		
10支裝 10-PCS	185L 20A 170R	—			0.13	0.15	0.16	0.09	0.09	0.15	BOX 5 pcs CARTON 100 pcs
	kg-5pcs	0.13			0.15	0.16	0.09	0.09	0.15		
	No./1set	5 (each 1)			5	5	5	5	5		
	ITEM No.	STS 10 * *			HIS 10 * *	HAS 10 * *	MAS 10 * *	KAS 10 * *	SAS 10 * *		

132
曲型
CRANK
type

DIMEN- SION	L			套裝 SET	扁 HAND W × T mm	半圓 HALF ROUND W × T mm	圓 ROUND W mm	方 SQUARE W mm	三角 TRIANGULAR W mm	每箱數量 No./BOX	
	TYPE	mm	mm								mm
5支裝 5-PCS	215L 17A 20R	—			0.29	0.31	0.29	0.22	0.25	0.29	BOX 5 pcs CARTON 100 pcs
	kg-5pcs	0.29			0.31	0.29	0.22	0.25	0.29		
	No./1set	5 (each 1)			5	5	5	5	5		
	ITEM No.	STC 05 * *			HIC 05 * *	HAC 5 * *	MAC 05 * *	KAC 05 * *	SAC 05 * *		
10支裝 10-PCS	185L 17A 15R	—			0.13	0.15	0.16	0.09	0.09	0.15	BOX 5 pcs CARTON 100 pcs
	kg-5pcs	0.13			0.15	0.16	0.09	0.09	0.15		
	No./1set	5 (each 1)			5	5	5	5	5		
	ITEM No.	STC 10 * *			HIC 10 * *	HAC 10 * *	MAC 10 * *	KAC 10 * *	SAC 10 * *		

133
直尺型
STRAIGHT
type

DIMEN- SION	L		套裝 SET	扁 HAND W × T mm	半圓 HALF ROUND W × T mm	圓 ROUND W mm	方 SQUARE W mm	三角 TRIANGULAR W mm	每箱數量 No./BOX	
	TYPE	mm								mm
5支裝 5-PCS	215L 105ℓ	—		0.29	0.31	0.29	0.22	0.25	0.29	BOX 5 pcs CARTON 100 pcs
	kg-5pcs	0.29		0.31	0.29	0.22	0.25	0.29		
	No./1set	5 (each 1)		5	5	5	5	5		
	ITEM No.	STM 05 * *		HIM 05 * *	HAM 05 * *	MAM 05 * *	KAM 05 * *	SAM 05 * *		
10支裝 10-PCS	185L 100ℓ	—		0.13	0.15	0.16	0.09	0.09	0.15	BOX 5 pcs CARTON 100 pcs
	kg-5pcs	0.13		0.15	0.16	0.09	0.09	0.15		
	No./1set	5 (each 1)		5	5	5	5	5		
	ITEM No.	STM 10 * *		HIM 10 * *	HAM 10 * *	MAM 10 * *	KAM 10 * *	SAM 10 * *		

ITEM No. * * assorted

	中齒 Second	細齒 Smooth
* *	02	03

■ 使用例

Use :

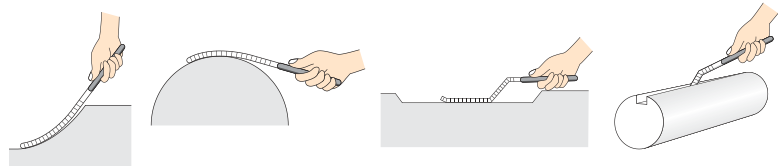

單紋齒萬能銼

UNI-CUT FILES

140



齒紋放大圖

特長

- 使用特殊高級鋼材SKS-8。
- 在單齒上開排屑槽。
- 適用於壓鑄件，輕合金，塑膠等。

Material : SKS-8(JIS)

Use : For steel, soft metals, plastics etc.
Fine finishing by single-cut teeth,
and smooth filing by chip breakers.

規格表 STANDARD TABLE

TYPE	DIMEN-SION		mm	mm	BOX pcs	kg- 5sets	ITEM NO.
	W × T	mm					
5支裝 5-PCS	11 × 3.5	215	110	25	1.48	HI 00515	
10支裝 10-PCS	7 × 2.5	185	85	25	0.69	HI 01015	

什錦銼

精修銼

SHARP CUT FILES

143



齒紋放大圖

特長

- 使用特殊高級鋼材SKS-8。
- 在單齒上增加細微的下齒紋，提高切削性。
- 特別推薦在模具製作等精度要求高的場合使用。

Material : SKS-8(JIS)

Use : Soft finishing for steel.

規格表 STANDARD TABLE

TYPE	DIMEN-SION		mm	mm	BOX pcs	kg- 5sets	ITEM NO.
	W × T	mm					
5支裝 5-PCS	11 × 3.5	215	110	25	1.48	HI 00516	
8支裝 8-PCS	9 × 3.0	200	100	40	1.54	HI 00816	
10支裝 10-PCS	7 × 2.5	185	85	50	1.37	HI 01016	

薄平銼 (什錦銼)

THIN HAND FILES

145

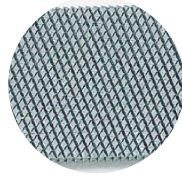

齒紋放大圖

特長

- 使用特殊高級鋼材SKS-8
- 薄型扁銼其前端部的柔韌性能提高工作的舒適性。

Material : SKS-8(JIS)

Use : By the thin thickness, it's slightly bended in using, and the shaving ability rises up.

規格表 STANDARD TABLE

TYPE	DIMEN-SION		mm	mm	BOX pcs	kg- 10pcs	ITEM NO.
	W × T	mm					
5支裝 5-PCS	10.5 × 1.5	215	105	10	0.40	HIU 05**	
8支裝 8-PCS	9 × 1.5	200	100	10	0.21	HIU 08**	
10支裝 10-PCS	7 × 1.0	185	80	10	0.13	HIU 10**	
12支裝 12-PCS	4 × 1.0	170	75	10	0.05	HIU 12**	

ITEM No. ** assorted

齒紋粗度	粗齒 Bastard	中齒 Second	細齒 Smooth
**	01	02	03

技能競賽審定銼

FILES FOR CONTEST

070

技能競賽審定銼

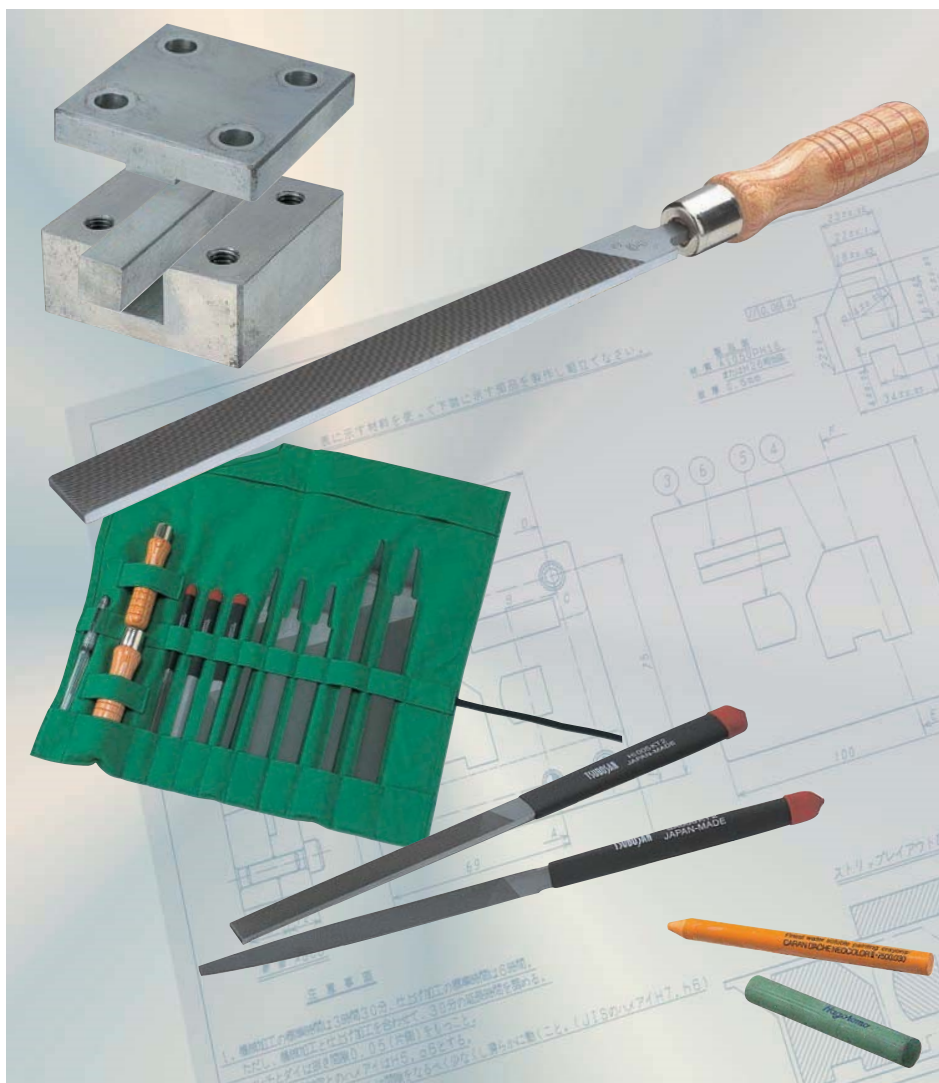

FILING CONTEST

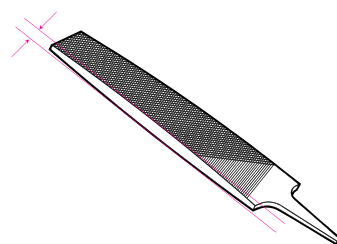

技能競技大會通常雲集一些高水準的工匠，進行高水準的技能競賽。精密部件的加工精度往往被要求控制在微米，TSUBOSAN在此助你一臂之力。

These “KENTEI MEDALIST” files are manufactured especially for the high skilled player in THE FILING CONTEST.

We, TSUBOSAN, support them who request the necessity in order to achieve a pure metal surface.

■特長

- 行業內首次來用二端錐形的銼刀面，確保能獲得被切削物的平衡度。
- 不塗容易造成積屑原因的沾性防銹油，因採用光亮鍍層，作業中積屑的剝落更為顯著。
(為長期保存，使用後請輕塗低粘度防銹油)
- 為保護銼刀刀部的鋒利，為您配備了厚全棉質地的環保防水（絲光紗加工）的收納袋。預定收納袋50個以上的客戶可在收納袋上印刷客戶公司的公司名和商標。（加工期一個月）

■Use

Curved Tapered Surfaces on both file faces can make the parallel finish of work.
Avalied of the clear coating (non-oil) to avoid the teeth clogging.
Packed in a green cloth pouch with water-proof, in order to protect points of File-Teeth.



審定銼套裝

070

規格表 STANDARD TABLE

審定技能套裝銼 (銼刀8支 圓木柄2個) KENTEI MEDALIST SET (8 FILES & 2 HANDLES)	 kg-set	 BOX pcs	ITEM NO.
	1.5	1set	SET-KT 10

審定銼-鉗工類型

075

規格表 STANDARD TABLE

INCH mm		DIMENSION SHAPE	齒紋粗度 (上齒紋) CUTTING No. W × T mm	剝齒 部位 CUTTING SECTION	軸方向的 錐形偏位 TAPERING DEFLECTION mm	kg-doz	BOX pcs	有無錐形 TAPER (Y/N)	表面防銹處理 ANTI-CORROSION	ITEM NO.
8	200	扁 #2 HAND	20.5 × 4.5	11		1.72	6	二端錐形 TAPERD TOP & END	光亮鍍層 (無防銹油) CLEAR-COATING (NON-OIL)	HI 200KT2
		扁 #3 HAND	20.5 × 4.5	21		1.72	6			HI 200KT3
10	250	扁 #2 HAND	24.5 × 5.3	10		3.22	6			HI 250KT2
8	200	方 #2 SQUARE	7.5	11		1.20	6	一端錐形 TAPERD TOP	光亮鍍層 (無防銹油) CLEAR-COATING (NON-OIL)	KA 200KT2
10	250	方 #2 SQUARE	12 × 11.5	10		2.26	6	菱形 STRAIGHT		KA 250KT2



技能競賽審定銼

審定銼-什錦銼

155

規格表 STANDARD TABLE

INCH mm		DIMENSION SHAPE	齒紋粗度 (上齒紋) CUTTING No. W × T mm	剝齒 部位 CUTTING SECTION	軸方向的 錐形偏位 TAPERING DEFLECTION mm	kg-25pcs	BOX pcs	有無錐形 TAPER (Y/N)	表面防銹處理 ANTI-CORROSION	ITEM NO.
—	115	扁 #2 HAND	10.5 × 3	13		1.48	5	一端錐形 TAPERD TOP	防銹油 OIL	HI 005KT2
		半圓 #3 ROUND	12 × 3.5	17		1.43	5	菱形 STRAIGHT		HA 005KT2
		三角 #3 TRIANGLE	9	17		1.44	5	一端錐形 TAPERD TOP		SA 005KT2



審定銼-其他

935

規格表 STANDARD TABLE

TYPE	SIZE		表面加工 surface protection	材質 MATERIAL	顏色 COLOR	kg-box	BOX pcs	ITEM NO.
圓木柄 wooden Handle	中 (M)	φ25 × 120		塗清漆 VARNISH	—	1.9	30	ME 900KTM
	大 (L)	φ30 × 140			—	2.0	50	ME 900KTL
收納袋 cloth pouch	W × T	42 × 39		絲光防水加工 WATERPROOF CLOTH	厚全棉 COTTON	綠色 GREEN	—	POUCH-KT



快速切削銼刀

QUICK CUT FILES

610 620



■把傳統的銼刀刃部經電介研磨（PAT）加工後，使刃物的刃部變得銳利。因為凹部比較深，適用於硬化塑膠，膠木，木材，輕金屬等容易積屑的材料。

■Use

“Electro-Polished Files.”
For Hard Plastic, Bakelite, Wood, Light-Metals, etc.

鉗工銼類

QUICK CUT FILES (ENGINEER'S TYPE)

610

規格表 STANDARD TABLE

INCH	mm	SHAPE DIMEN- SION	扁	半圓	圓	方	三角
			HAND W × T mm	HALF ROUND W × T mm	ROUND φ mm	SQUARE W mm	TRIANGULAR W mm
6	150	WXT/W	16 × 4	16 × 4.5	φ6	6	12
		kg-doz	0.82	0.74	0.46	0.56	1.10
		BOX pcs	12	12	12	12	12
		ITEM No.	QHI 150*	QHA 150*	QMA 150*	QKA 150*	QSA 150*
8	200	WXT/W	21 × 5	21 × 6	φ8	8	15
		kg-doz	1.72	1.82	1.00	1.20	2.08
		BOX pcs	6	6	6	6	6
		ITEM No.	QHI 200*	QHA 200*	QMA 200*	QKA 200*	QSA 200*
10	250	WXT/W	25 × 6	25 × 7	φ10	10	17
		kg-doz	3.22	3.00	1.88	2.26	3.24
		BOX pcs	6	6	6	6	6
		ITEM No.	QHI 250*	QHA 250*	QMA 250*	QKA 250*	QSA 250*
12	300	WXT/W	30 × 7	30 × 8.5	φ12	12	20
		kg-doz	5.50	5.26	3.32	4.00	5.28
		BOX pcs	6	6	6	6	6
		ITEM No.	QHI 300*	QHA 300*	QMA 300*	QKA 300*	QSA 300*
14	350	WXT/W	34 × 7.5	34 × 10	φ15	15	22
		kg-doz	8.00	8.12	5.62	7.08	7.14
		BOX pcs	6	6	6	6	6
		ITEM No.	QHI 350*	QHA 350*	QMA 350*	QKA 350*	QSA 350*

ITEM No. *
assorted

齒紋粗度
ROUGHNESS

粗齒
Bastard

中齒
Second

細齒
Smooth

油齒
Dead Smooth

*

*

什錦銼類

QUICK CUT FILES (ASSORTED TYPE)

620

規格表 STANDARD TABLE

TYPE	DIMEN- SION		套裝 SET	扁	半圓	圓	方	三角
	mm	mm		HAND W × T mm	HALF ROUND W × T mm	ROUND φ mm	SQUARE W mm	TRIANGULAR W mm
5支裝 5-PCS	215L	110ℓ	—	11 × 3.5	12 × 3.8	φ5.5	5.5	9.0
	kg-25pcs		1.38	1.48	1.43	1.13	1.30	1.44
	No./1set		5 (each 1)	5	5	5	5	5
	ITEM No.		QST 005*	QHI 005*	QHA 005*	QMA 005*	QKA 005*	QSA 005*
8支裝 8-PCS	200L	100ℓ	—	9 × 3.0	9.5 × 3.0	φ4.3	4.3	7.5
	kg-25pcs		0.88	0.96	1.01	0.66	0.78	1.01
	No./1set		5 (each 1)	5	5	5	5	5
	ITEM No.		QST 008*	QHI 008*	QHA 008*	QMA 008*	QKA 008*	QSA 008*
10支裝 10-PCS	185L	85ℓ	—	7 × 2.5	7.3 × 2.5	φ3.2	3.2	6.0
	kg-25pcs		0.56	0.69	0.64	0.37	0.40	0.69
	No./1set		5 (each 1)	5	5	5	5	5
	ITEM No.		QST 010*	QHI 010*	QHA 010*	QMA 010*	QKA 010*	QSA 010*
12支裝 12-PCS	170L	70ℓ	—	4 × 2.0	4.2 × 2.0	φ2.5	2.5	4.0
	kg-25pcs		0.29	0.33	0.31	0.25	0.25	0.29
	No./1set		5 (each 1)	5	5	5	5	5
	ITEM No.		QST 012*	QHI 012*	QHA 012*	QMA 012*	QKA 012*	QSA 012*

■1套5支裝。

柔韌銼

硬鉸鏢-900

BRIGHT-900 Series

650 660



「硬鉸鏢-900系列」是壺三獨創的製品，同時適用於軟質材料和硬質材料。特別是不易積屑。具有耐磨性，耐久性，良好排屑等卓越性能。
由於在鉸刀素材上採用了壺三獨創的光亮鍍層技術，其表面硬度實現了革新。

特長

- 較之普通鉸刀其耐久性提高了3-6倍。
(因被切削材料而異)
- 防銹，防腐蝕性能卓越。能有效改善因海洋及多濕環境導致鉸刀銹蝕而劣化的狀況。
- 剝離切削粉性能卓越，杜絕鉸刀積屑現象發生。因為能去除切削粉，故能持續進行順暢的切削作業。

用途

- HV900 (HRC67) 的卓越表面硬度實現了用一支鉸刀可以處理從木工製品，蠟，塑膠製品，鋁材，模具鋼，不銹鋼，陶瓷等軟質材料和硬質材料。

Use

By TSUBOSAN original technology of the Hard Coating, "BRIGHT-900 Series" raised its function of Steel Files up to the superior status which could be used for the wide range between Soft-Metal and Hard-Metal.

"BRIGHT-900 Series" resist against its own defacement, corrosion and clog (3 characters).

The File surface of "BRIGHT-900 Series" has HV900(HRC67) hardness, so the File life would be expanded in 3~6 times longer than non-coating Steel File.

For example,

"BRIGHT-900 Series" are availed on Wood, Plastic, Soft-Metal (Al · Cu···), Stainless Steel, Mold-Die Steel, Ceramic, Glass, etc..

柔
韌
鉸

硬鉸鏢-900鉗工鉸

BRIGHT-900 (ENGINEER'S TYPE)

650

規格表 STANDARD TABLE

INCH	mm	SHAPE	DIMEN-SION	扁	半圓	圓
				HAND	HALF ROUND	ROUND
				W × T mm	W mm	W mm
6	150	W × T		16 × 4	16 × 4.5	φ6
		kg-do _z		0.82	0.74	0.46
		BOX pcs		12	12	12
		ITEM No.		BRHI 150*	BRHA 150*	BRMA 150*
8	200	W × T		21 × 5	21 × 6	φ8
		kg-do _z		1.72	1.82	1.00
		BOX pcs		6	6	6
		ITEM No.		BRHI 200*	BRHA 200*	BRMA 200*
10	250	W × T		25 × 6	25 × 7	φ10
		kg-do _z		3.22	3.00	1.88
		BOX pcs		6	6	6
		ITEM No.		BRHI 250*	BRHA 250*	BRMA 250*

ITEM No. *	assorted
齒紋粗度	ROUGHNESS *
中齒	Second 2
細齒	Smooth 3

硬鉸鏢-900什錦鏢

BRIGHT-900 (DIE SINKERS TYPE)

660

規格表 STANDARD TABLE

DIMEN-SION	L	套裝 SET	扁	半圓	圓	方	三角
			HAND	HALF ROUND	ROUND	SQUARE	TRIANGULAR
TYPE	mm		W × T mm	W × T mm	W mm	W mm	W mm
5支裝 5-PCS	215L 110ℓ	—	11 × 3.5	12 × 3.8	φ5.5	5.5	9.0
	kg-25pcs	1.38	1.48	1.43	1.13	1.30	1.44
	No./1set	5 (each 1)	5	5	5	5	5
	ITEM No.		BRST 505*	BRHI 505*	BRHA 505*	BRMA 505*	BRKA 505*

1套5支裝。

和鉗工鏢類，什錦鏢類一樣，可根據客戶要求定制不同形狀，不同尺寸和齒紋粗度的鉸刀。

渗陶瓷銼刀

CERAMICS COATING FILES

510

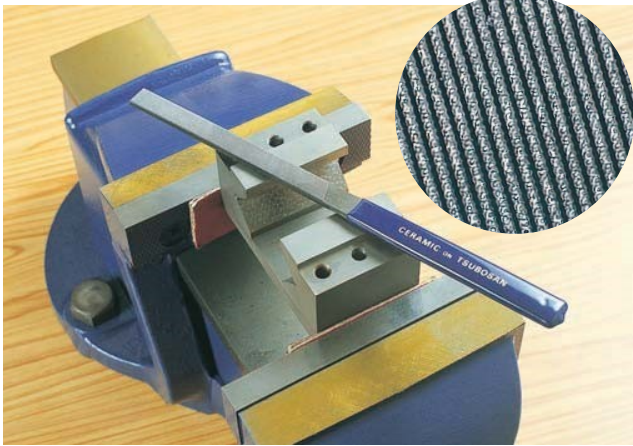

■ 渗陶瓷銼刀切削試驗
(Shaving Test of CERAMICS COATING FILES)

■ 把陶瓷擴散浸透到母材料中的最新技術。
VC (Carbon Vanadium) is permeated on the file surface.

■ 特長

- 表面硬度HRC65以上。
- 耐磨性和耐腐蝕性出色。
- 使用壽命延長5-10倍。
- 有效剝離切削粉。

■ 用途

- 鐵系金屬，鍛造SC材料，大理石，玻璃，磨刀石。
- 能有效防止黃銅粉末，鋁末堵住齒紋的現象。
- 能長期使用於海上，海濱等潮濕環境。

■ Characteristic :

Superior to the hardness, Corrosion, Defacement, Clog. The hardness on file surface is more than HRC65, and it's life is 5~10 times as much as steel-files.

■ Use : Carbon steel (C≤0.5%), Glass, etc.

For KEY repairing work, Marine work, etc.

紅線...陶瓷光亮處理
黑線...通常處理

● 試驗內容

被切削材料HRC41· φ16mm 圓片
工作壓力: 4kg f 切削速度: 7.5m/min
工作行程長度: 100mm

● 試驗結果

通常處理的銼刀經5000次切削後，其銼削感及銼削品質下降，性能減退。經陶瓷光亮處理後的銼刀經10,000次試驗也能充分發揮其出色性能。

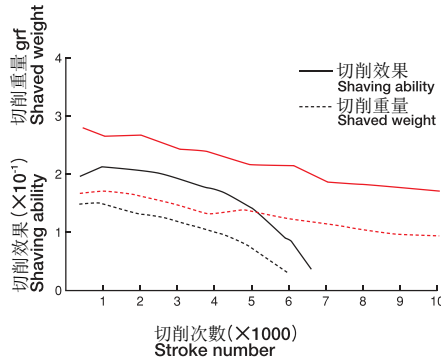

RED LINE...CERAMICS COATING
BLACK LINE...STANDARD

● Test condition

Test piece : φ16mm, HRC41
Direct pressure : 4kg f
Shaving speed : 7.5m/min
Stroke : 100mm

● Test results

Standard Files :
Functionable upto 5,000 strokes.
Ceramics Coating Files :
Even functionable over 10,000 strokes.

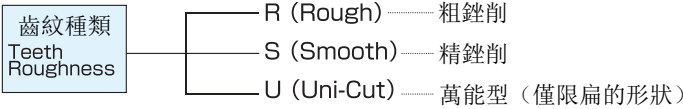

ITEM No. * assorted

	粗銼削 Rough	精銼削 Smooth	萬能型 Uni Cut
*	R	S	U

■ 1套5支裝。

規格表 STANDARD TABLE

DIMENSION	L		套裝 SET	扁 HAND W × T mm	半圓 HALF ROUND W × T mm	圓 ROUND W mm	方 SQUARE W mm	三角 TRIANGULAR W mm	每箱數量
	mm	mm							
5支裝 5-PCS	215L	110L	—	11.0 × 3.5	12.0 × 3.8	φ5.5	5.5	9.0	BOX
	kg-25pcs		1.49	1.69	1.48	1.34	1.36	1.62	pcs 25
	No./1set		5 (each 1)	5	5	5	5	5	
	ITEM No.		ST 005C *	HI 005C *	HA 005C *	MA 005C *	KA 005C *	SA 005C *	
10支裝 10-PCS	185L	85L	—	7.0 × 2.5	7.3 × 2.5	φ3.2	3.2	6.0	BOX
	kg-25pcs		0.63	0.76	0.70	0.45	0.49	0.72	pcs 25
	No./1set		5 (each 1)	5	5	5	5	5	
	ITEM No.		ST 010C *	HI 010C *	HA 010C *	MA 010C *	KA 010C *	SA 010C *	

陶瓷機用銼

SUPER SAW (CERAMICS COATING FILES)

511



規格表 STANDARD TABLE

DIMENSION	L		套裝 SET	扁 HAND W × T mm	半圓 HALF ROUND W × T mm	圓 ROUND W mm	方 SQUARE W mm	三角 TRIANGULAR W mm	每箱數量
	mm	mm							
105L	φ5.0A		—	7.2 × 3.1	8.4 × 3.2	φ5.2	4.6	6.3	BOX
kg-25pcs			0.43	0.45	0.39	0.43	0.40	0.40	pcs 25
No./1set			5 (each 1)	5	5	5	5	5	
ITEM No.			ST 105C2	HI 105C2	HA 105C2	MA 105C2	KA 105C2	SA 105C2	

■ 請裝置在電動，氣壓工具上使用。

■ Use : By airforced or electric tool.

塗鈦超級機用銼

TIN SUPER HAND (Titanium Coated)

520



■手動 BY HAND 請使用手柄 (902)。

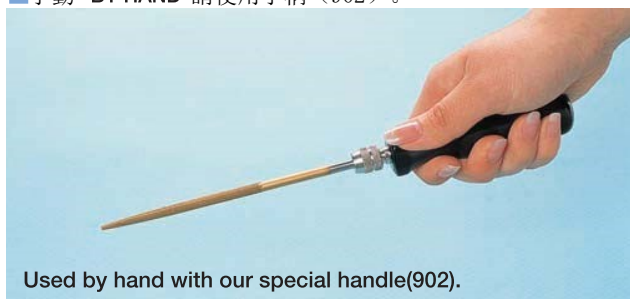

Used by hand with our special handle(902).

■行業內首次使用耐磨性，耐熱性卓越的高速鋼SKH-51。

■特長

●延長使用壽命。

(使用電動，氣壓工具時能承受每分鐘3700衝程的切削速度)

SKH-51鋼

C	Cr	W	Mo	V
0.84%	4.03%	6.05%	5.10%	1.81%

■Material : SKH-51 (JIS) High Speed Steel

It's hardened under a vacuum environment, further more Tin (Titanium Nitride) is plated on the file-teeth.

■Use : By the coating Tin, Both heat resisting and wear resistance grow up highly. It's superior to the high hardness, corrosion, Defacement, Clog.

It can endure the shaving speed at the rate of 3,700 strokes per min.

■氣壓，電動工具

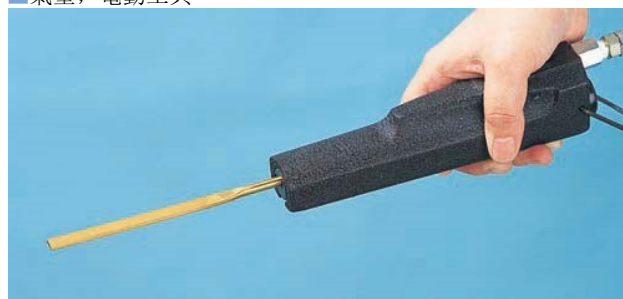

柔
韌
銼

規格表 STANDARD TABLE

			套裝 SET	扁 HAND W × T mm	半圓 HALF ROUND W × T mm	圓 ROUND W mm	方 SQUARE W mm	三角 TRIANGULAR W mm
150L	100 l	φ5.0A	—	7.0 × 2.5	8.2 × 2.8	φ5.0	5.5 × 3.2	6.0
kg- 5pcs			0.16	0.16	0.15	0.16	0.15	0.16
BOX pcs			5 (each 1)	5	5	5	5	5
ITEM No.			ST 1550T	HI 1550T	HA 1550T	MA 1550T	KA 1550T	SA 1550T
			套裝圓 R-SET	圓-3.0 ROUND-3.0 W mm	圓-3.5 ROUND-3.5 W mm	圓-4.0 ROUND-4.0 W mm	圓-4.5 ROUND-4.5 W mm	圓-5.0 ROUND-5.0 W mm
150L	75(100) l	φ5.0A	—	φ3.0	φ3.5	φ4.0	φ4.5	φ5.0
kg- 5pcs			0.14	0.12	0.13	0.13	0.14	0.16
BOX pcs			5 (each 1)	5	5	5	5	5
ITEM No.			ST 15MAT	MA 1530T	MA 1535T	MA 1540T	MA 1545T	MA 1550T

■1套5支裝。

手柄 HANDLE (FOR TIN SUPER HAND)

902

		BOX	ITEM NO.
120A	21.5B	kg- 50pcs	PE 902S
		PCS	
		50	



902

精密銼 PRECISION NEEDLE FILES



規格表 STANDARD TABLE

DIMENSION	L A mm	套裝 SET	扁 HAND	半圓 HALF ROUND
			W × T mm	W × T mm
305 5支裝 5-PCS	200 × φ3.9	—	7.8 × 1.5	6.2 × 2.3
	kg-25pcs	0.50	0.52	0.50
	No./1set	5 (each 1)	5	5
	ITEM No.	ST 0055 *	HI 0055 *	HA 0055 *
308 8支裝 8-PCS	180 × φ3.4	—	6.7 × 1.3	5.2 × 2.1
	kg-40pcs	0.55	0.60	0.55
	No./1set	8 (each 1)	8	8
	ITEM No.	ST 0085 *	HI 0085 *	HA 0085 *
310 10支裝 10-PCS	160 × φ2.9	—	5.7 × 1.2	4.5 × 1.8
	kg-50pcs	0.47	0.50	0.47
	No./1set	10 (each 1)	10	10
	ITEM No.	ST 0105 *	HI 0105 *	HA 0105 *
312 12支裝 12-PCS	140 × φ2.4	—	5.0 × 1.0	4.0 × 1.4
	kg-60pcs	0.35	0.36	0.35
	No./1set	12 (each 1)	12	12
	ITEM No.	ST 0125 *	HI 0125 *	HA 0125 *

精密鉗工銼 SUPER FINE ENGINEER'S FILES

331



CUTTING No. : #6 (STANDARD)

規格表 STANDARD TABLE

INCH	mm	平 HAND	BOX	ITEM No.	
		W × T mm	kg-doz		pcs
4	100	13.0 × 2.5	0.31	12	HI 10056
5	125	16.0 × 2.9	0.53	12	HI 12556
6	150	17.5 × 3.1	0.76	12	HI 15056
8	200	20.0 × 3.5	1.29	6	HI 20056
10	250	21.5 × 4.1	2.30	6	HI 25056

- 適用於平面細微處加工作業。
- 其他形狀包括半圓，圓，方，三角等。
- Other shapes :Half Round, Round, Square, Triangular

超細銼 VERY THIN HAND DITCH FILES

340



規格表 STANDARD TABLE

L mm	扁 HAND	半圓 HALF ROUND	圓 ROUND	方 SQUARE	三角 TRIANGULAR
150L 40 l	2.0 × 1.2	2.5 × 1.2	φ2.0	2.0	3.0
kg-120pcs	0.63	0.64	0.57	0.57	0.64
No./1BOX	120	120	120	120	120
ITEM No.	GHI 1502	GHA 1502	GMA 1502	GKA 1502	GSA 1502

圓線狀銼 LINE ROUND FILES

353



規格表 STANDARD TABLE

mm	名稱	BOX	ITEM No.
W mm	kg-120pcs	pcs	
100	18細圓	120	LMA 0856
100	21細圓	120	LMA 1256
100	24細圓	120	LMA 1556
100	30細圓	120	LMA 2056
100	36細圓	120	LMA 2556

圓 ROUND	方 SQUARE	三角 TRIANGULAR	梯形 TRAPEZOID	尖扁 FLAT	橢圓 OVAL	刀口 KNIFE	腹圓 BALANCE EDGE	尖竹葉 FLAT LEAF	平竹葉 HAND LEAF	每箱數量 No./1BOX	刀稜銼 BARETTE
W mm	W mm	W mm	W × T mm	W × T mm	W × T mm	W × T mm	W × T mm	W × T mm	W × T mm		W × T mm
φ3.9	3.3	5.0								BOX	
0.48	0.48	0.50								pcs	
5	5	5								25	
MA 0055 *	KA 0055 *	SA 0055 *									
φ3.4	2.8	4.2	5.2 × 2.3	7.5 × 1.5	4.0 × 2.3					BOX	7.5 × 1.5
0.55	0.55	0.55	0.55	0.55	0.55					pcs	0.70 (kg-50pcs)
8	8	8	8	8	8					40	50
MA 0085 *	KA 0085 *	SA 0085 *	SI 0085 *	SH 0085 *	DE 0085 *						BT 0085 *
φ2.9	2.5	3.7	4.5 × 1.8	6.0 × 1.1	3.7 × 2.2	4.5 × 2.2	4.5 × 1.8			BOX	
0.45	0.45	0.45	0.45	0.45	0.45	0.45	0.45			pcs	
10	10	10	10	10	10	10	10			50	
MA 0105 *	KA 0105 *	SA 0105 *	SI 0105 *	SH 0105 *	DE 0105 *	KH 0105 *	HM 0105 *				
φ2.4	2.0	3.0	3.8 × 1.2	5.0 × 1.0	3.0 × 2.0	4.0 × 1.2	3.5 × 1.5	4.5 × 1.5	4.5 × 1.5	BOX	6.0 × 1.1
0.33	0.33	0.33	0.33	0.33	0.33	0.33	0.33	0.33	0.33	pcs	0.47 (kg-50pcs)
12	12	12	12	12	12	12	12	12	12	60	50
MA 0125 *	KA 0125 *	SA 0125 *	SI 0125 *	SH 0125 *	DE 0125 *	KH 0125 *	HM 0125 *	SS 0125 *	HS 0125 *		BT 0125 *

可自由彎曲銼

BENDABLE PRECISION NEEDLE FILES

370

規格表 STANDARD TABLE

L A		套裝 SET	扁 HAND	半圓 HALF ROUND	圓 ROUND	方 SQUARE	三角 TRIANGULAR	尖竹葉 FLAT LEAF	每箱數量
mm			W × T mm	W × T mm	W mm	W mm	W mm	W × T mm	No./1BOX
160L	φ2.9A	—	5.6 × 1.4	5.6 × 1.7	φ3.0	2.6	3.6	5.2 × 2.2	BOX
kg-30pcs		0.34	0.36	0.35	0.32	0.35	0.35	0.34	pcs
No./1set		6 (each 1)	6	6	6	6	6	6	30
ITEM No.		BST 0656	BHI 0656	BHA 0656	BMA 0656	BKA 0656	BSA 0656	BSS 0656	(5 sets)

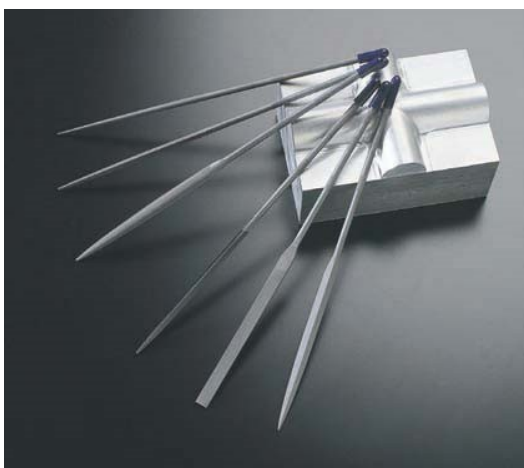

折彎處



■特長

- 用手能自由彎曲成希望的角度。

■用途

- 亞鉛金型，用於放電加工用電極等複雜形狀模型的修整。

■Use : It can be bended by hand easily. So with the hoping radius, it's a used for the modification of precision Dies and Gear.

精密銼

火花塞專用銼

POINT FILES

358



規格表 STANDARD TABLE

L A		截面尺寸 POINT	kg-60pcs	BOX	ITEM No.
mm		W × T mm		PCS	
135L	70 ℓ	8.0 × 1.0	0.6	60	PHI 0056

雕金專用銼

CHASING FILES

360





用途

●用於雕金細工，寶石飾品等貴金屬的加工。

Use : For Chasing artwork and Jewelry art works.

規格表 STANDARD TABLE

 mm	 W × T mm	 kg-doz	ITEM No.
200	16 × 2.9	0.83	

齒科技工用銼

DENTAL FILES

365

扁 HAND



雙頭半圓 HALF ROUND (FOUR-IN-ONE)







用途

●齒科技工用銼，用於石膏模型的修整。

Use : To modify the plaster teeth model.

規格表 STANDARD TABLE

形狀 SHAPE	全長 TOTAL LENGTH mm	 W × T mm	 kg-doz	ITEM No.
扁 	125	16 × 2.9	0.45	
雙頭半圓 	200	14 × 3.5	0.80	



DIAMOND FILES



■用Ni电极沉积法固定金刚石颗粒。粘合力，研削度和耐磨性能得到提高。

■用途

●使用于陶瓷，超硬金属，锻件等高硬度材料。

■使用注意

●轻轻接触被切削件便能够充分研削。

●湿式研削也有效，请加入少量油后使用。

■Use : Please use it after dropping a little of oil on the working point.

Diamond Grids are fixed by Ni-plating process.

Especially it's very available for the very high hardened materials modify, i.e. Ceramics, Hard-Metals, hardened steel etc..

S類型 (金剛石粒度#200)

S-TYPE (DIAMOND GRID NO.#200)

411

規格表 STANDARD TABLE



RED-GRIP

DIMEN-SION	TYPE			套裝 SET (每種形狀1支)	扁 HAND W × T mm	半圓 HALF ROUND W × T mm	圓 ROUND W mm	方 SQUARE W mm	三角 TRIANGULAR W mm
	L	φ	A						
S-5	200L	70 ℓ	φ4.0A	—	8.0 × 2.0	7.0 × 2.5	φ4.0	3.5	5.0
	kg-1set			0.14	0.15	0.15	0.14	0.13	0.14
	No./1set			5 (each 1)	5	5	5	5	5
	ITEM No.			DSST 0520	DSHI 0520	DSHA 0520	DSMA 0520	DSKA 0520	DSSA 0520
S-8	180L	60 ℓ	φ3.5A	—	6.5 × 1.5	6.0 × 2.0	φ3.5	3.0	4.3
	kg-1set			0.11	0.12	0.12	0.11	0.11	0.11
	No./1set			5 (each 1)	5	5	5	5	5
	ITEM No.			DSST 0820	DSHI 0820	DSHA 0820	DSMA 0820	DSKA 0820	DSSA 0820
S-10	170L	50 ℓ	φ3.0A	—	5.8 × 1.1	5.5 × 1.5	φ3.0	2.7	3.8
	kg-1set			0.09	0.10	0.09	0.09	0.09	0.09
	No./1set			5 (each 1)	5	5	5	5	5
	ITEM No.			DSST 1020	DSHI 1020	DSHA 1020	DSMA 1020	DSKA 1020	DSSA 1020
S-12	170L	40 ℓ	φ2.5A	—	5.0 × 1.0	4.6 × 1.4	φ2.5	2.2	3.0
	kg-1set			0.08	0.08	0.08	0.08	0.08	0.08
	No./1set			5 (each 1)	5	5	5	5	5
	ITEM No.			DSST 1220	DSHI 1220	DSHA 1220	DSMA 1220	DSKA 1220	DSSA 1220

●#200以為都可以對應加工。

○ S-10 平 ■ #400 DSHI 1040 ■ #600 DSHI 1060
○ S-12 平 ■ #400 DSHI 1240 ■ #600 DSHI 1260

K類型 (金剛石粒度#150)

K-TYPE (DIAMOND GRID NO.#150)

421

規格表 STANDARD TABLE



BLUE-GRIP

DIMEN-SION	TYPE			套裝 SET (每種形狀1支)	扁 HAND W × T mm	半圓 HALF ROUND W × T mm	圓 ROUND W mm	方 SQUARE W mm	三角 TRIANGULAR W mm
	L	φ	A						
K-5	215L	80 ℓ	—	—	11.0 × 3.5	12.0 × 3.8	φ5.5	5.5	9.0
	kg-1set			0.30	0.35	0.31	0.25	0.27	0.30
	No./1set			5 (each 1)	5	5	5	5	5
	ITEM No.			DKST 0510	DKHI 0510	DKHA 0510	DKMA 0510	DKKA 0510	DKSA 0510
K-8	200L	50 ℓ	—	—	9.0 × 3.0	9.5 × 3.0	φ4.3	4.3	7.5
	kg-1set			0.22	0.26	0.14	0.17	0.18	0.23
	No./1set			5 (each 1)	5	5	5	5	5
	ITEM No.			DKST 0810	DKHI 0810	DKHA 0810	DKMA 0810	DKKA 0810	DKSA 0810
K-10	185L	50 ℓ	—	—	7.0 × 2.5	7.3 × 2.5	φ3.2	3.2	6.0
	kg-1set			0.15	0.18	0.17	0.12	0.12	0.15
	No./1set			5 (each 1)	5	5	5	5	5
	ITEM No.			DKST 1010	DKHI 1010	DKHA 1010	DKMA 1010	DKKA 1010	DKSA 1010
K-12	170L	50 ℓ	—	—	4.0 × 2.0	4.2 × 2.0	φ2.5	2.5	4.0
	kg-1set			0.09	0.09	0.09	0.08	0.09	0.09
	No./1set			5 (each 1)	5	5	5	5	5
	ITEM No.			DKST 1210	DKHI 1210	DKHA 1210	DKMA 1210	DKKA 1210	DKSA 1210

●能對應 50 ℓ ~ 100 ℓ 的電鍍加工。

○ K-5 平 ■ #150(100 ℓ) DKHI 0510(100)
○ K-5 平 ■ #200(80 ℓ) DKHI 0520(80) (100 ℓ) DKHI 0520(100)



各種特殊金剛石銼

■特長

- 形狀，尺寸，金剛石粒度，金剛石長度等一應俱備。能應對各種作業。
- 還能根據客戶要求定制特殊形狀的金剛石銼。

■金剛石粒度

- 根據把手顏色的不同容易識別作業中金剛石的粒度。

■Use : Various kinds of SHAPES, DIMENSIONS and DIAMOND GRID NUMBERS(#) are combined to polish the surfaces of the hardened Metals and Ceramics in works. Furthermore ,TSUBOSAN accepts the customer's special order with a will. According to each difference of Grip Color, a worker can distinguish each roughness of Diamond File during his work.

	紫 (PURPLE)	#100	
	藍 (BLUE)	#150	
	紅 (RED)	#200	
	綠 (GREEN)	#300	
	黃 (YELLOW)	#400	
	黑 (BLACK)	#600	

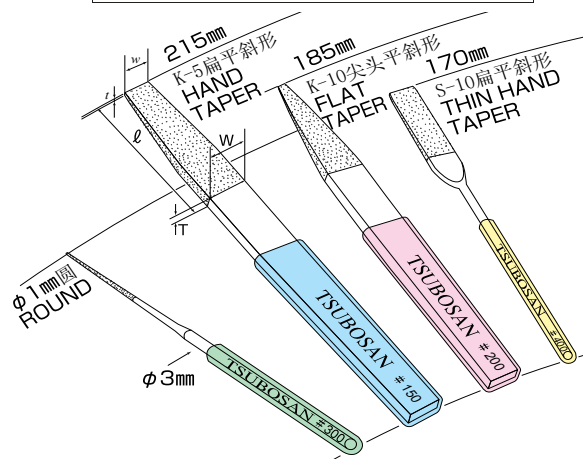
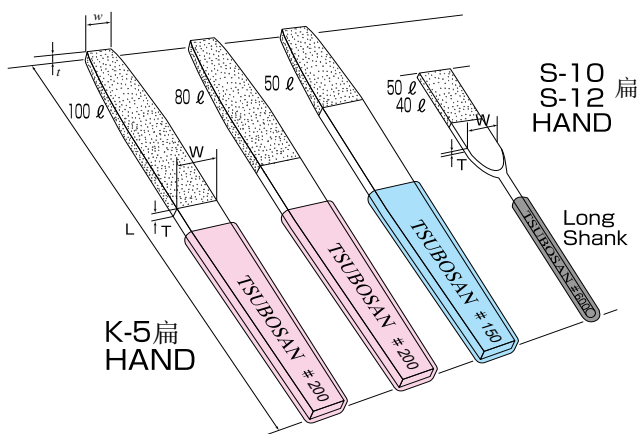

金剛石平斜銼 DIAMOND TAPERED FORM 426

規格表 STANDARD TABLE

TYPE	DIMENSION	L		W × T mm	w × t mm	BOX pcs	kg-5 pcs	ITEM No.				
		L	ℓ mm					#150	#200	#300	#400	#600
K-5	扁平斜形 HAND TAPER	215	50	11.0×2.0	10.0×0.9	5	0.26	DKHI051T(50)	—	—	—	—
		215	80	11.0×3.0	10.0×0.9	5	0.26	DKHI051T(80)	—	—	—	—
K-8	扁平斜形 HAND TAPER	200	50	9.0×2.5	8.0×0.7	5	0.19	DKHI081T	DKHI082T	—	—	—
		185	50	7.0×1.8	6.5×0.7	5	0.12	DKHI101T	DKHI102T	—	DKHI104T	DKHI106T
K-10	尖頭平斜形 FLAT TAPER	185	50	7.0×2.0	1.5×0.6	5	0.11	—	DKSH102T	—	—	—
		170	50	4.0×1.8	3.7×0.7	5	0.06	DKHI121T	DKHI122T	—	DKHI124T	DKHI126T
K-12	尖頭平斜形 FLAT TAPER	170	50	4.0×1.4	1.5×0.6	5	0.06	—	DKSH122T	—	DKSH124T	DKSH126T
		極細扁平斜形 VERY THIN HAND TAPER	170	50	2.5×1.3	2.0×0.4	5	0.02	—	DGHI122T	—	—

金剛石薄平銼 DIAMOND THIN HAND FORM 427

規格表 STANDARD TABLE

TYPE	DIMENSION	L		W × T mm	w × t mm	BOX pcs	kg-5 pcs	ITEM No.				
		L	ℓ mm					#150	#200	#300	#400	#600
S-8	薄平 THIN HAND	180	50	6.5×0.8	—	5	0.12	—	DSHI082U	DSHI083U	—	—
		170	40	5.8×1.1	—	5	0.06	DSHI101U	DSHI102U	DSHI103U	—	—
S-10	0.5mm 薄平 0.5mm THIN HAND	170	40	5.8×0.5	—	5	0.06	—	DSHI102U(0.5)	—	DSHI104U(0.5)	—
		薄平斜 THIN HAND TAPER	170	30	5.8×0.7	5.8×0.4	5	0.06	—	DHI102TU	DHI103TU	—
極細平 VERY THIN HAND DITCH		170	50	2.5×1.3	—	5	0.02	—	DGHI122U	—	—	—

金剛石銼