

# KRACHT



## VOLUMEK

Valve Position Indicator 5



## Description

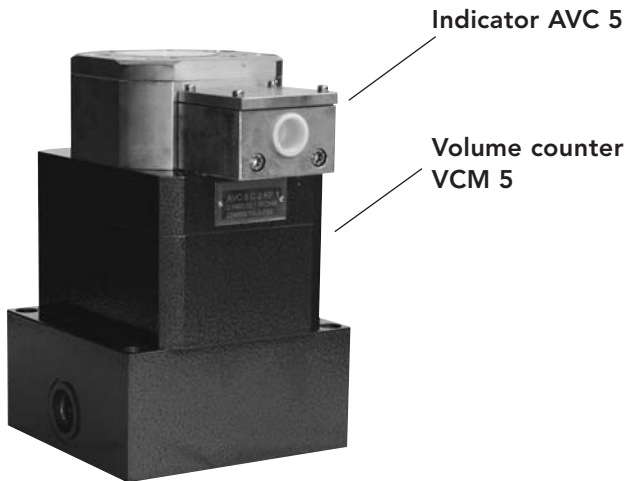

The VOLUMEK 5 valve position indicator consists of one volume counter and one indicator device.

Mounted on a connecting plate, the VOLUMEK 5 carries out the functions of measuring and counting the adjustment track of hydraulically operated ship armatures.

The measurement unit is seawater-resistant and suitable for being mounted on deck.

The volumetrically ascertained armature position can be counted and read optically directly from the device or electronically via the potentiometer or end switch.

## Modular design

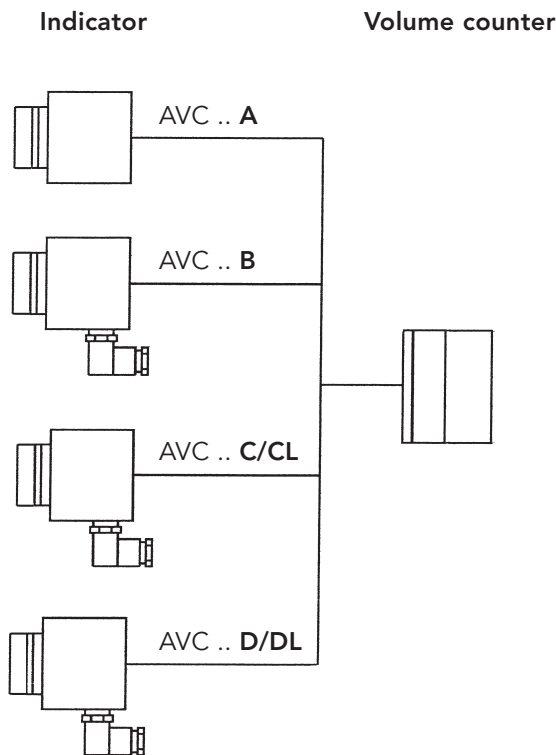

### VOLUMEK Indicator

- AVC .. A      Optically
- AVC .. B      Open /Close switches
- AVC .. C/CL   Potentiometer
- AVC .. D/DL   Potentiometer + o/c switches

**Functions**

The code-indicator is a part of the VOLUMEK 5 and builds the measurement unit. The rotation of the gear type volume counter will be sent to the code-indicator gear via a permanent magnetic coupling. The gear reduction is dimensioned for a counter direction of app. 180°. The counter is limited via an integrated friction coupling by two adjustable end posts and with that, is reset. The drive axle of the magnetic coupling is equipped with a display indicator and visibly shows the speed of the volume counter.

By doing this, the density in the mechanical end positions of the actuators or cylinders of the ship armature can be determined.

The code-indicator is completely separated from the hydraulic circuit; abrasion caused by shaft seals is avoided in this manner. The housing of the code-indicator is made of a seawater-resistant special brass. All exterior fixing materials are made of A 2.

**Type code – Indicator**

**Ordering example**

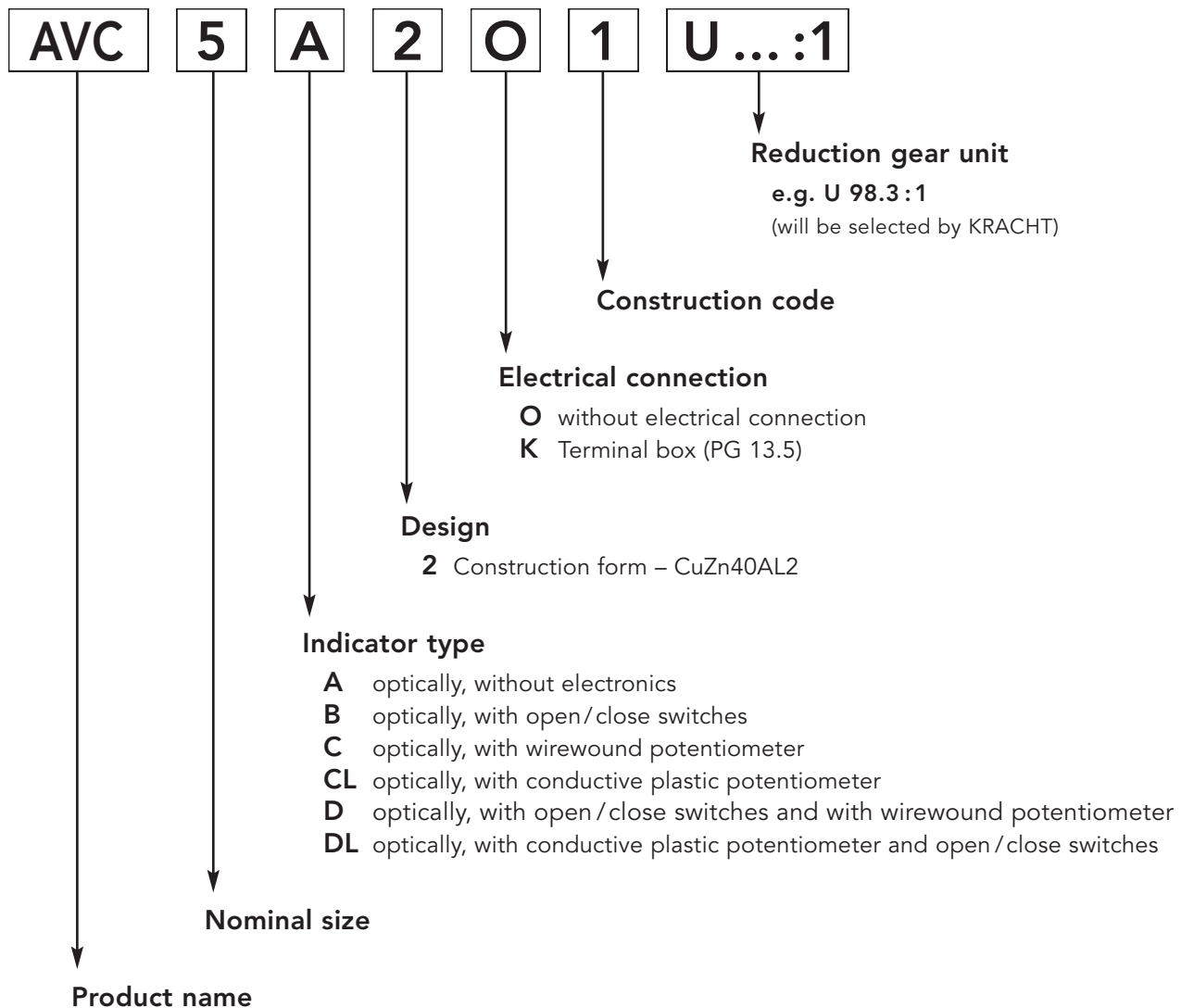

**Contact assignment – Indicator type B**

Miniature round connector series 723  
View of the solder-contact side of the pin inputs

Contact plate

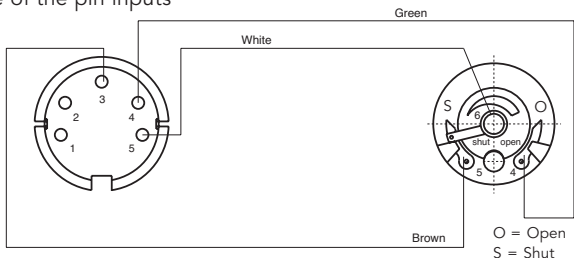

**Contact assignment – Indicator type C, CL**

Miniature round connector series 723  
View of the solder-contact side of the pin inputs

Potentiometer

Contact plate

Open ca. 800 Ohm  
Shut ca. 220 Ohm

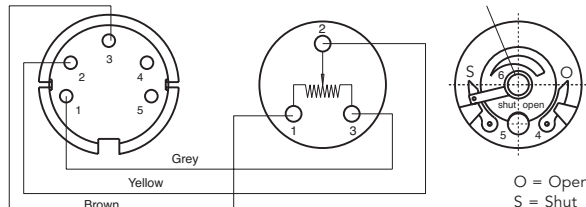

**Contact assignment – Indicator type D, DL**

Miniature round connector Series 723  
View of the solder-contact side of the pin inputs

Potentiometer

Contact plate

Open ca. 800 Ohm  
Shut ca. 220 Ohm

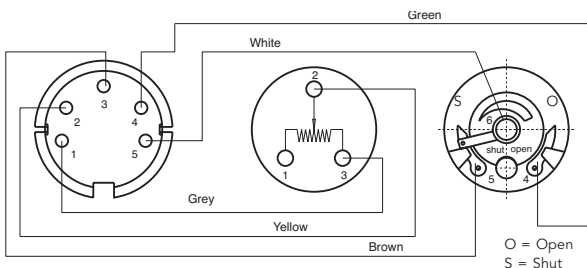

**Technical data potentiometer**

Electrical data	Wirewound potentiometer (C, D)	Conductive plastic potentiometer (CL, DL)
Connection resistance R	1 K $\Omega$	1 K $\Omega$
Resistance tolerance	$\pm 10\%$	$\pm 20\%$
Linearity	$\pm 1.0\%$	$\pm 2\%$
Max. wiper current in case of malfunction	100 mA	1 mA
Power rating P	1 W/85 °C (185 °F)	0,2 W to 55 °C (131 °F)
Dielectric strength	900 VAC/1 min	500 V <sub>eff</sub> /1 min
Insulating resistance	10 G $\Omega$ at 500 V DC	> 1 G $\Omega$ at 500 V DC
Resistance resolution	0.37 %	
<b>Environmental conditions</b>		
Operating temperature	-55 °C ... +150 °C (-67 °F ... +302 °F)	-55 °C ... +105 °C (-67 °F ... +221 °F)
Climatic rating	55/150/56	
Degree of protection	IP 67	
Vibrations	10 G (30-2000 Hz, 0.75 mm)	
Shock	50 G (half sine pulse, 7 ms)	

**Dimensions**

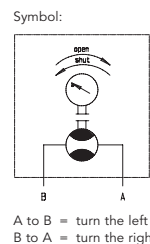
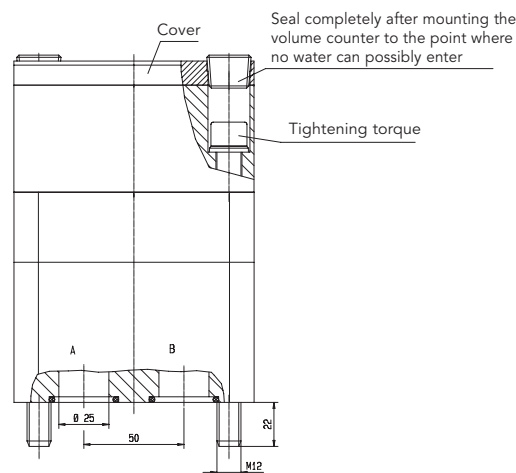
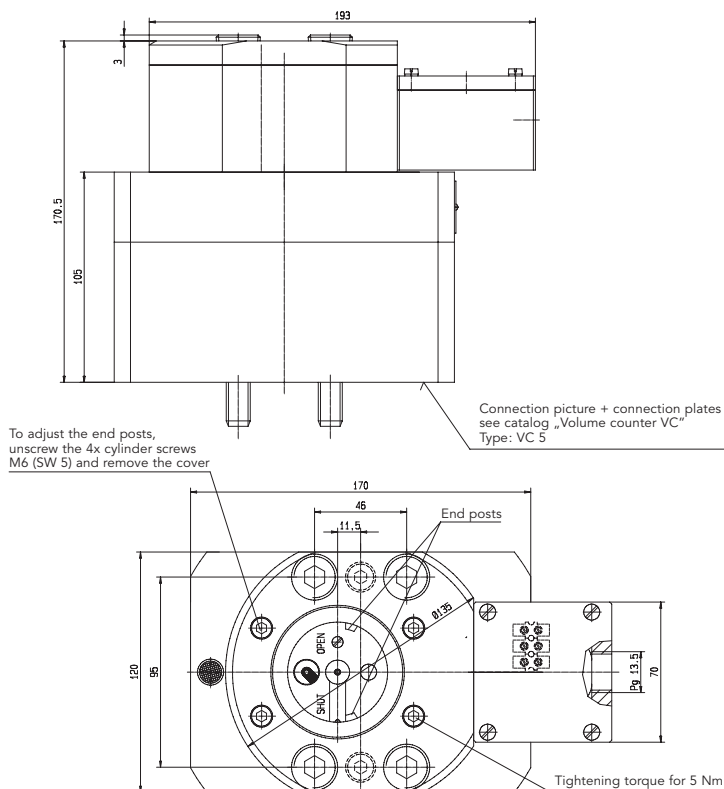

**Function**

The volume counter is suitable for all known hydraulic fluids that have a minimum lubricity and do not act aggressively against the materials in use (housing-cast iron, steel ball bearings, steel gears and steel interior parts, NBR or FKM seals).

The movement of the gears is directly transferred to the indicator through a permanent magnetic coupling. There is no direct connection between the indicator and the hydraulic circuit.

**General characteristics**

Design	Gear motor
Connection	Flange
Weight	13 kg
Mounting position	optional
Dimensions	see page 7
Ambient temperature	$\vartheta_{m \min} = -20\text{ °C} (-4\text{ °F})$ $\vartheta_{m \max} = +60\text{ °C} (+140\text{ °F})$
Liquid temperature	$\vartheta_{m \min} = -20\text{ °C} (-4\text{ °F})$ $\vartheta_{m \max} = +80\text{ °C} (+176\text{ °F})$

**Hydraulic characteristics**

Geom. tooth volume	$V_{gz} = 5.222\text{ cm}^3$
No. of teeth	$Z = 13$
Max. operating pressure	$p_{e \max} = 300\text{ bar}$
Max. flow rate	$Q = 150\text{ l/min}$
Viscosity	$v_{\min} = 20\text{ mm/s}$ $v_{\max} = 380\text{ mm/s}$ (higher viscosity on request)
Hydraulic fluids	Mineral oil acc. to DIN 51524/25 (other fluids on request)

**Type code – Volume counter**

Ordering example

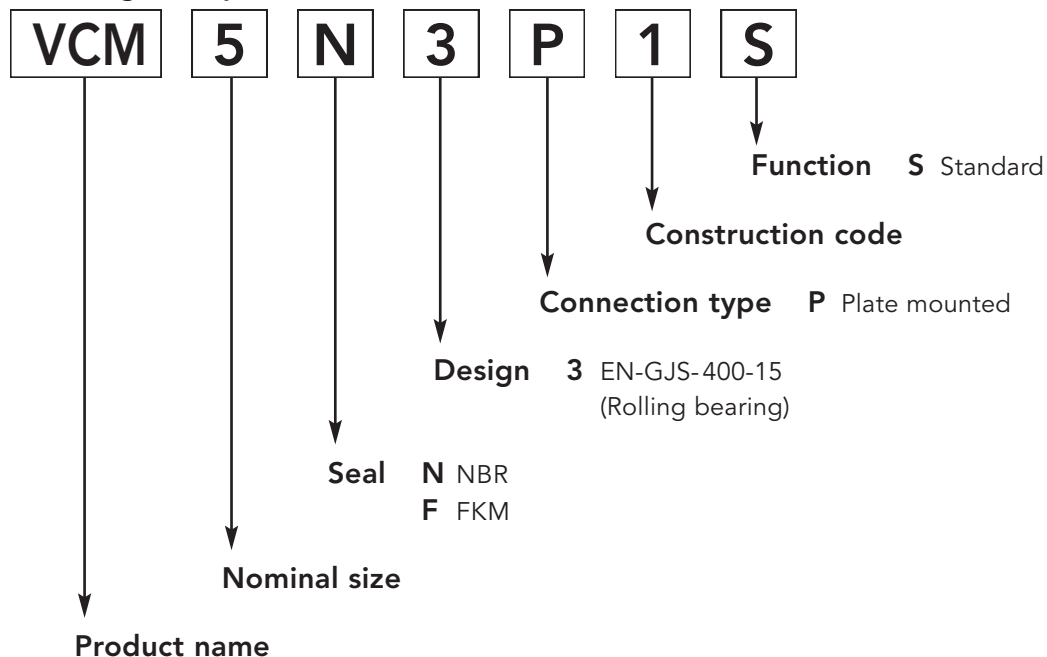

Dimensions VCM 5...S (Standard)

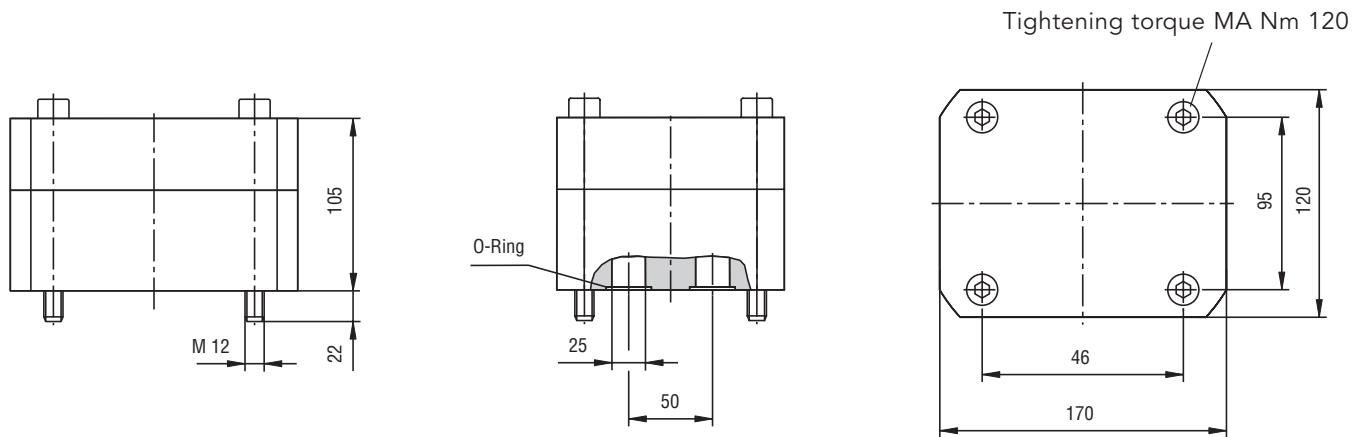

Connection Hole Pattern

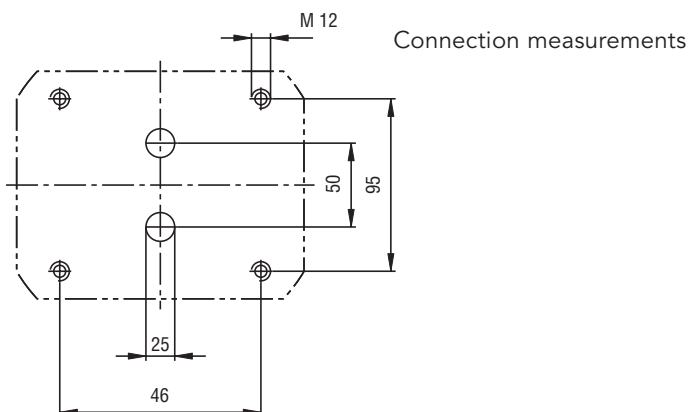

Type code – Connection plates

Ordering example

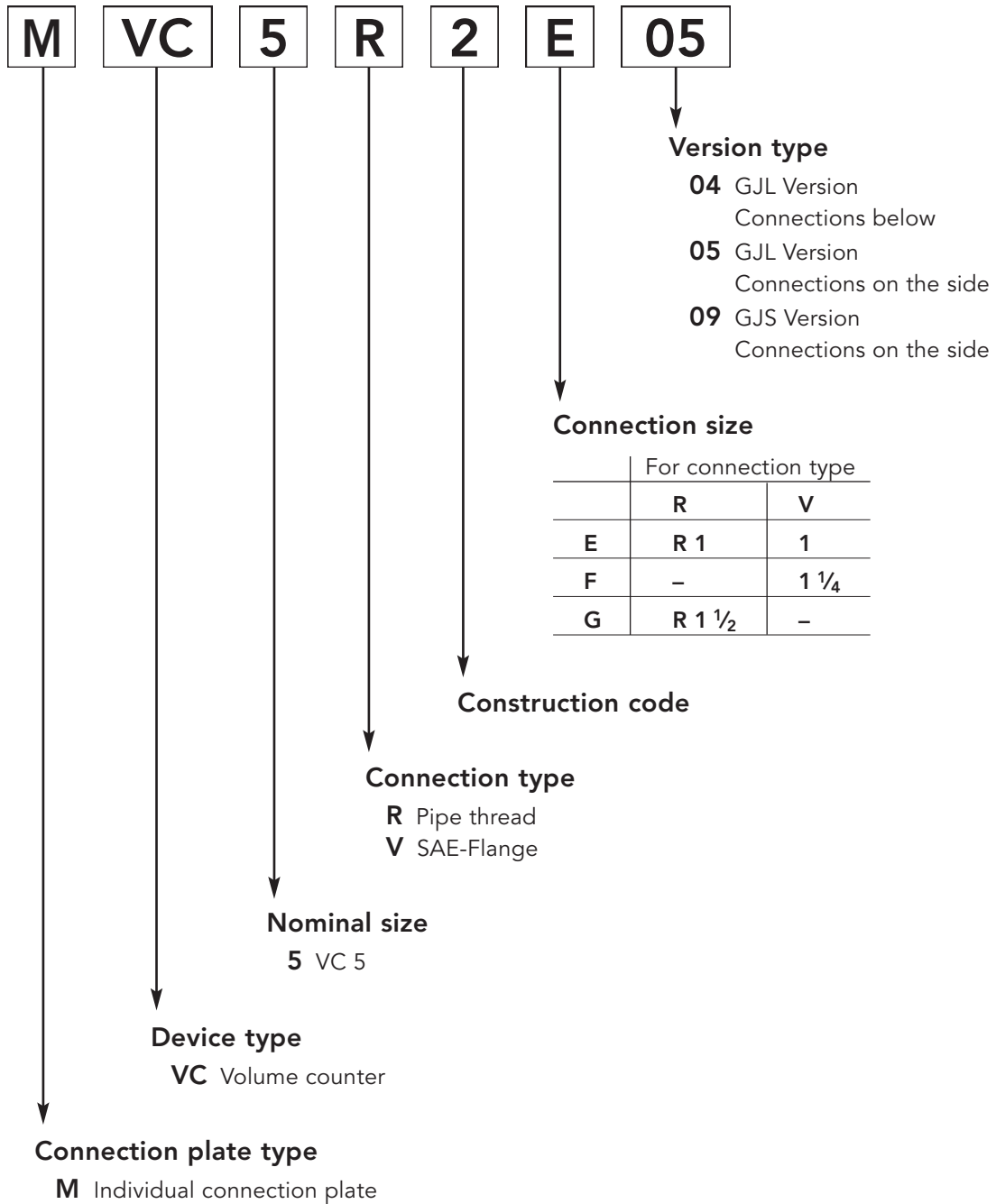



**Dimensions**

**With threaded connection on the side**

Ordering code	Weight kg	Measurements																	
		m	A	B	C	E	F	G	H	J	K	L	M	N	P	R	c	d	e
MVC 5 R 2 E 05	14.0	160	165	80	140	145	9	15	9	46	95	50	25	M12/24 t	28	1	42	G1	19
MVC 5 R 2 G 09	17.8	170	165	100	140	145	9	15	9	46	95	50	25	M12/24 t	42	1	58	G1½	23

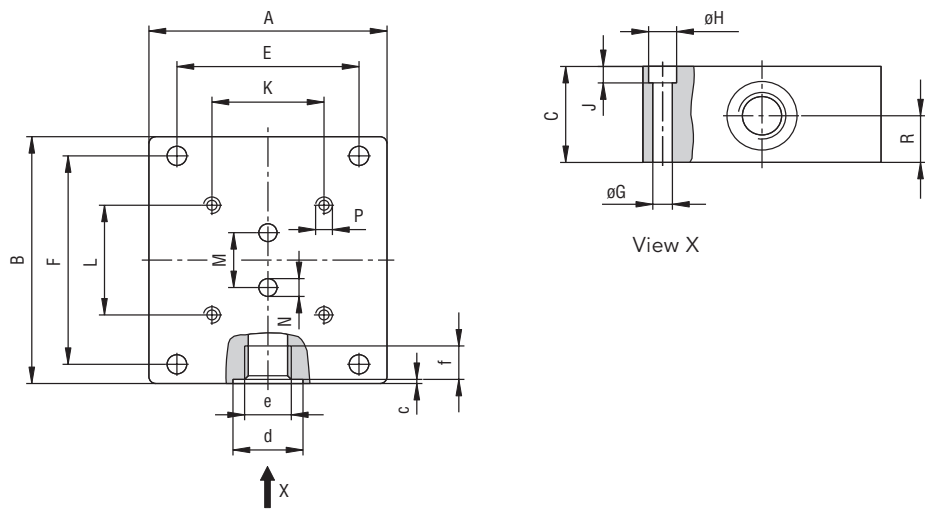

**With SAE flange connection on the side**

Ordering code	Weight kg	Measurements																	
		m	A	B	C	E	F	G	H	J	K	L	M	N	P	R	a	b	e
MVC 5 V 2 E 05	14.0	160	165	80	140	145	9	15	9	46	95	50	25	M12/24 t	40	57.2	27.8	25	M12/24 t
MVC 5 V 1 F 09	15.1	160	165	90	140	145	9	15	9	46	95	50	25	M12/24 t	50	66.7	31.8	31.5	M14/25 t

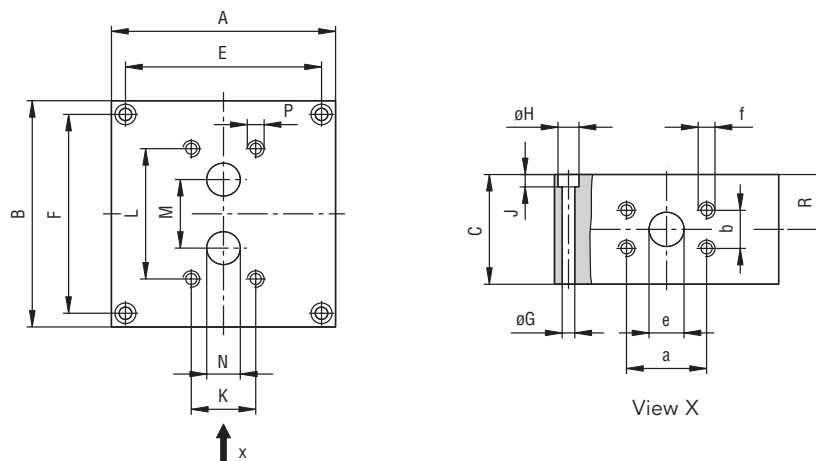

**Dimensions**

**With threaded connection on the rear side**

Ordering Code	Weight kg	Measurements																	
		m	A	B	C	E	F	G	H	J	K	L	M	N	P	R	c	d	e
MVC 5 R 2 E 04	9.6	160	165	55	140	145	9	15	9	46	95	50	25	M12/24t	55	1	42	G1	19

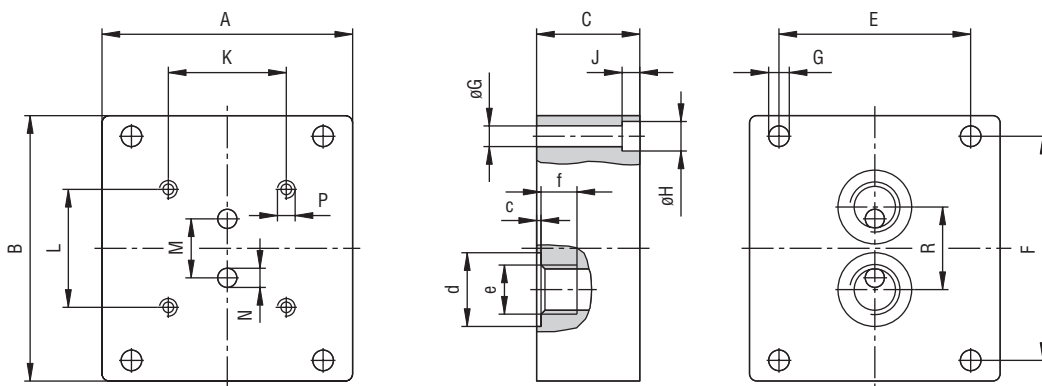

**With SAE flange connection on the rear side**

Ordering Code	Weight kg	Measurements																	
		m	A	B	C	E	F	G	H	J	K	L	M	N	P	R	a	b	e
MVC 5 R 2 E 04	9.5	160	165	55	140	145	9	15	9	46	95	50	25	M12/24t	80	57.2	27.8	25	M12/24t

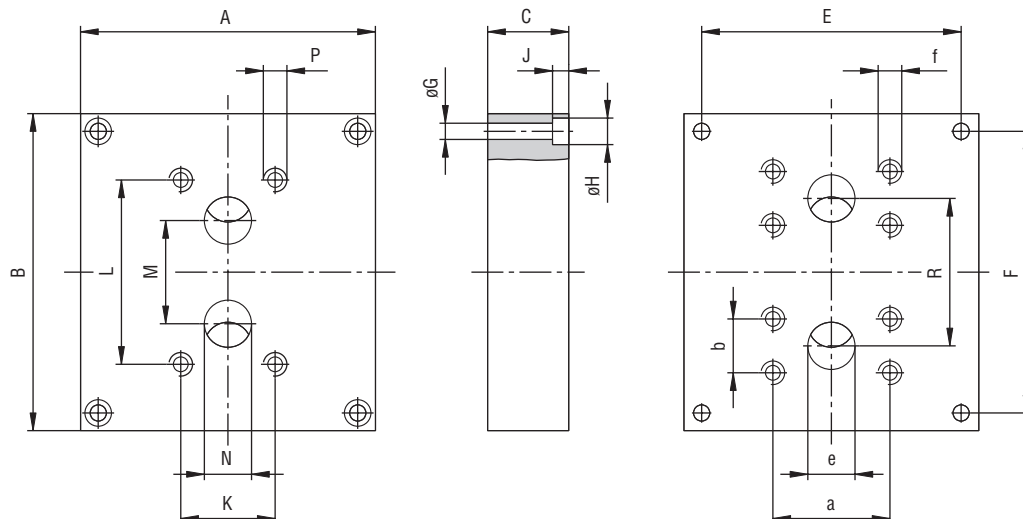



# Product Portfolio

## Transfer Pumps

Transfer pumps for lubricating oil supply equipment, low pressure filling and feed systems, dosing and mixing systems.

## Mobile Hydraulics

Single and multistage high pressure gear pumps, hydraulic motors and valves for construction machinery, vehicle-mounted machines.

## Flow Measurement

Gear and turbine flow meters and electronics for volume and flow metering technology in hydraulics, processing and laquering technology.

## Industrial Hydraulics / Test Bench Construction

Cetop directional control and proportional valves, hydraulic cylinders, pressure, quantity and stop valves for pipe and slab construction, hydraulic accessories for industrial hydraulics (mobile and stationary use).

Technology Test benches / Fluid Test benches.



*Volume 5/GB/06.07*

# KRACHT