

KRACHT

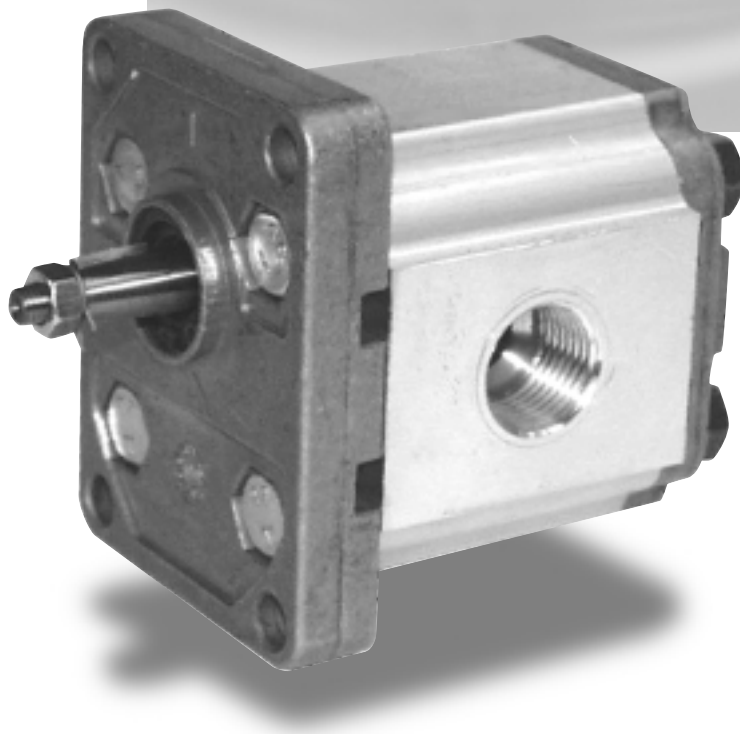
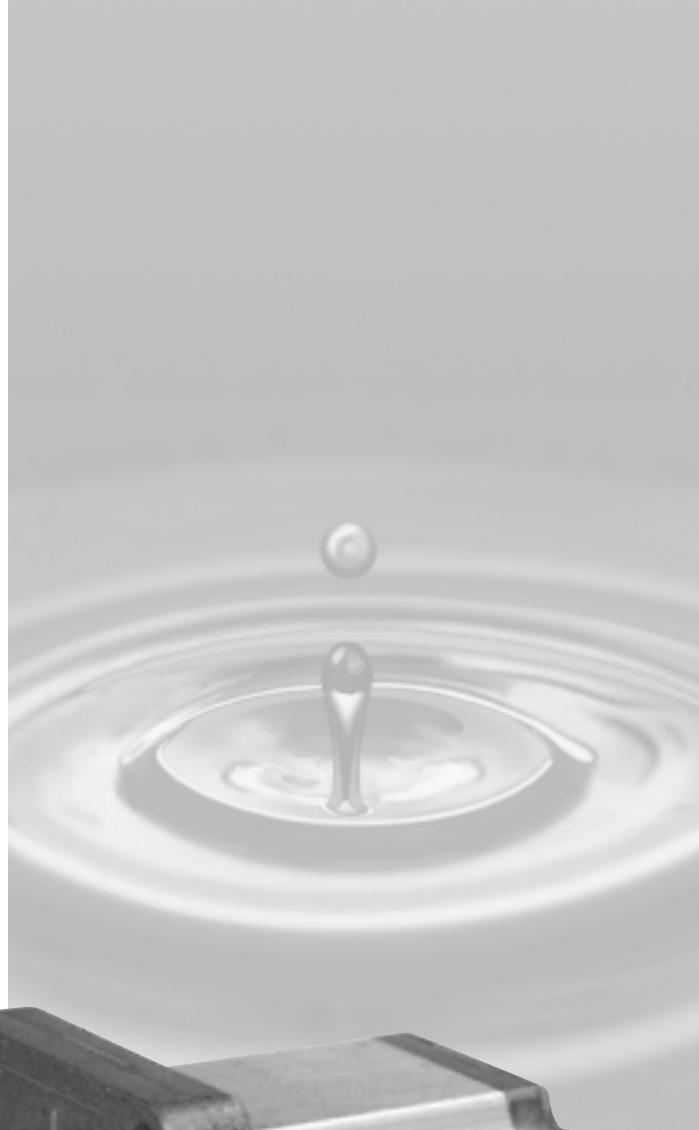

**High Pressure Gear Pumps
KP 0**

High Pressure Gear Pumps KP 0

Design of KP 0 gear pumps

Description

According to its design, the Kracht KP 0 external gear pump belongs to the type of so-called gland type pumps. The essential functional elements, gearing and bearing glands are located in an aluminium housing of high-strength extruded alloy, which is limited laterally by the the cover plate and flange cover. The gearing, made of case hardened steel with surface hardening, consists of the drive shaft wheel and pin wheel. The highest manufacturing quality is guaranteed by shaving the tooth flanks. The shaft journals are finely ground. Due to the high number of teeth ($n = 12$) and the special tooth shape, a considerable reduction in design-related volume flow fluctuation and the associated pressure pulsation is achieved.

Technical information

1. External forces

External forces acting on the drive shaft end have an influence on the operation of the bearing glands. Radial and axial forces are not permissible. An end bearing must be used for the purpose of absorbing external forces.

2. Direction of rotation

The following definition applies to the direction of rotation, looking at the end of the drive shaft:

Shaft with right-hand rotation: pumping direction from left to right.
Shaft with left-hand rotation: pumping direction from right to left.

General parameters

Fixing type	Flange fixing
Pipe connection	Threaded connection
Direction of rotation	Right or left
Weight	See dimensional sheets
Installation location	Any
Ambient temperature	$\vartheta_{u \min} = -20\text{ °C}$ $\vartheta_{u \max} = +60\text{ °C}$

Operating parameters

Operating pressure	
Suction side	$p_{e \min} = -0,3\text{ bar (underpressure)}$ $p_{e \max} = 2\text{ bar}$
Short-run	$p_{e \max} = 2.5\text{ bar}$
Pressure side	$p_{\max} = \text{see technical data}$
Fluid temperature	$\vartheta_{m \max} = 85\text{ °C}$
Viscosity range	$\nu_{\min} = 12\text{ mm}^2/\text{s}$ $\nu_{\max} = 800\text{ mm}^2/\text{s}$
Recommended oil cleanness	Class 19/16 according to ISO/DIS 4406 ⇨ Class 10 according to NAS 1638
Recommended filtering	Filter with filtration quotient $\beta_{25} \geq 75\text{ for } \dots 280\text{ bar}$ $\beta_{40} \geq 75\text{ for } \dots 100\text{ bar}$
Recommended viscosity range	$\nu = 25 \dots 100\text{ mm}^2/\text{s}$
Rate of flow	see table page 3
Drive capacity	see table page 3
Working substances	Mineral oil according to DIN 51524/25 Engine oil according to DIN 51511 Bio-oils from the „HEES“ group can be used up to 70 °C and at approx. 20% reduced maximum pressure (please enquire)

Materials

Housing	Aluminium
Bearing arrangement	Gland with multi-material plain bearings
Shafts and gear wheels	Surface-hardened and ground case-hardened steel according to DIN 17210
Seals	NBR

Technical data

Capacity rated quantity	Geom. capacity	Max. pressure	Nominal pressure	Continuous pressure	Max. speed
	V_g	p_{\max}	p_N	p_D	n_{\max}
	cm^3/r	bar	bar	bar	rpm
1	1.1	280	260	220	3500
2	1.9	280	260	220	3500
3	3.1	260	250	210	3500
4	4.4	260	250	210	3500
6	6.1	230	210	180	3000
8	7.9	200	180	160	3000

Max. pressure = Pressure peak
Nominal pressure $p_N < 6s = 50\%$ continuous duty
See time / pressure chart
Max. number of switching actuations: 30 / min
Pressure data apply for $\nu \geq 30\text{ mm}^2/\text{s}$

Time / pressure chart

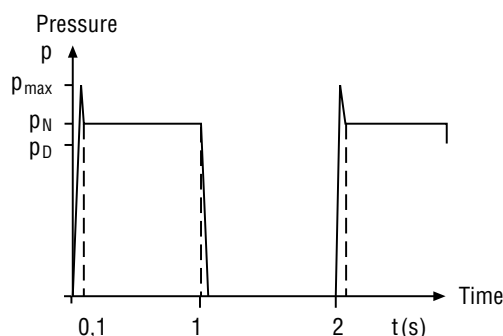

Capacity Rated quantity	Minimum speed at $p = \dots\text{ bar}$ 1/min					
	$\dots 100$	$\dots 120$	$\dots 150$	$\dots 180$	$\dots 200$	$\dots 250$
1	600	700	900	1200	1300	1400
2	600	700	900	1200	1300	1400
3	500	700	900	1000	1200	1400
4	500	700	900	1000	1200	1400
6	500	700	900	1000	1100	–
8	500	700	900	1000	–	–

High Pressure Gear Pumps KP 0

Calculation formulae for hydro pumps

Parameters, symbols, units

1. Rate of flow / absorbing volume	Q	l/min
2. Geom. capacity / absorbing volume	V_g	cm ³ /r
3. Pressure	p	bar
4. Speed	n	rpm
5. Moment	M	Nm
6. Power	P	kW
7. Overall efficiency	η_{tot}	-
8. Volumetric efficiency	η_{vol}	-
9. Hydr./mech. efficiency	η_{hm}	-
10. Velocity of flow	v	m/s
11. Pipe diameter	d	mm

General

$$Q_{th} = V_g \cdot n, \quad \eta_{tot} = \eta_{vol} \cdot \eta_{hm},$$

$$M = 9549 \cdot \frac{P}{n}, \quad v = 21.22 \frac{Q}{d^2}$$

Standard values for KRACHT products at nominal operating point

KP 0	η_{tot}	η_{vol}
1 to 4	≈ 0.75	≈ 0.85
6 to 8	≈ 0.90	≈ 0.90

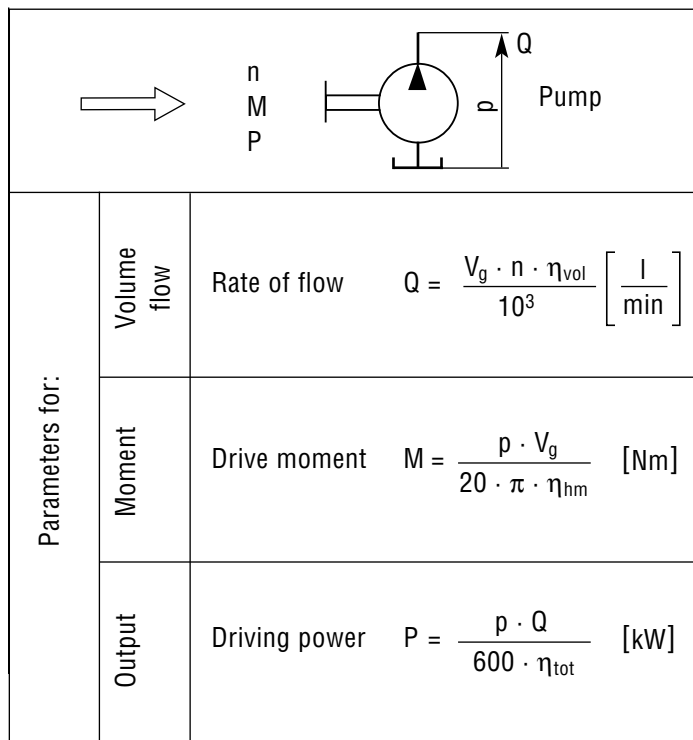

Rate of flow at n = 1495 rpm

Rate of flow Q in l/min at 34 mm²/s
Pressure p in bar

	20	60	100	140	180	220	260
1	1.55	1.50	1.45	1.40	1.35	1.34	1.33
2	2.80	2.70	2.65	2.60	2.55	2.50	2.40
3	4.70	4.65	4.60	4.55	4.50	4.45	-
4	6.30	6.25	6.20	6.15	6.10	6.05	-
6	9.00	8.95	8.90	8.85	8.80	-	-
8	11.75	11.60	11.50	11.45	11.40	-	-

Required drive capacity at n = 1495 rpm

Pressure p in bar

	20	60	100	140	180	220	260
1	0.10	0.25	0.38	0.56	0.70	0.84	0.95
2	0.15	0.32	0.54	0.77	1.06	1.36	1.60
3	0.25	0.57	0.91	1.30	1.60	2.00	-
4	0.30	0.75	1.20	1.60	2.05	2.50	-
6	0.40	1.05	1.70	2.30	2.95	-	-
8	0.50	1.30	2.10	3.05	3.90	-	-

High Pressure Gear Pumps KP 0

Type key

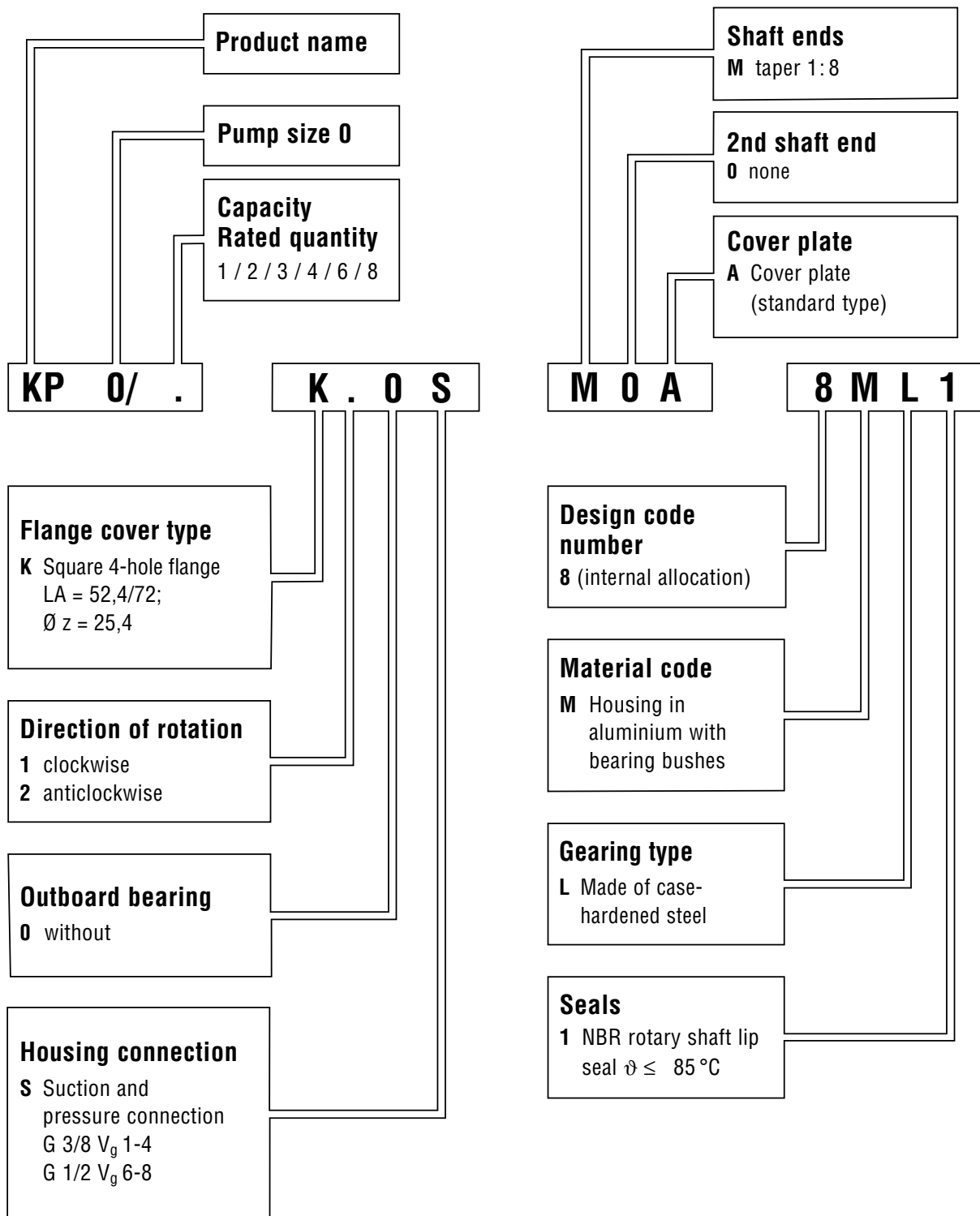

- Multiple pump combinations
- Motors
- Other shaft and flange types
- FKM rotary shaft lip seal possible on request

High Pressure Gear Pumps KP 0

Type K-flange, tapered shaft

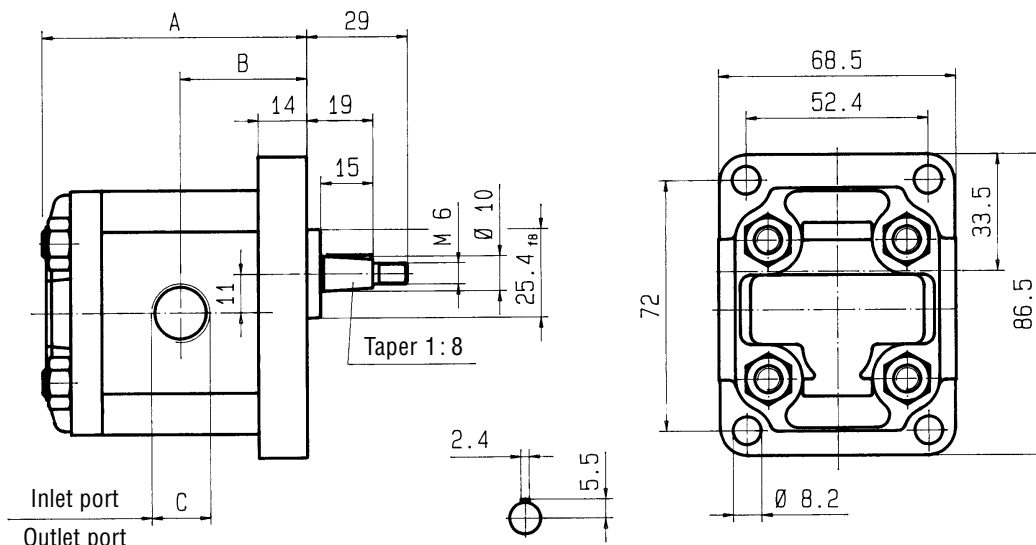

Displayed direction of rotation: right

Shaft: Taper 1:8

With left-handed direction of rotation, suction and pressure connection will be opposite

Order example: **KP 0/1 K10S M0A 8ML1**

Nominal Displacement	1	2	3	4	6	8
A	68	71.5	71.5	76.5	86.5	86.5
B	32.4	33.3	33.3	36.7	42.0	42.0
C	3/8" BSP			1/2" BSP		
Weight kg	0.9	0.95	0.95	1.05	1.2	1.2

Bell housing

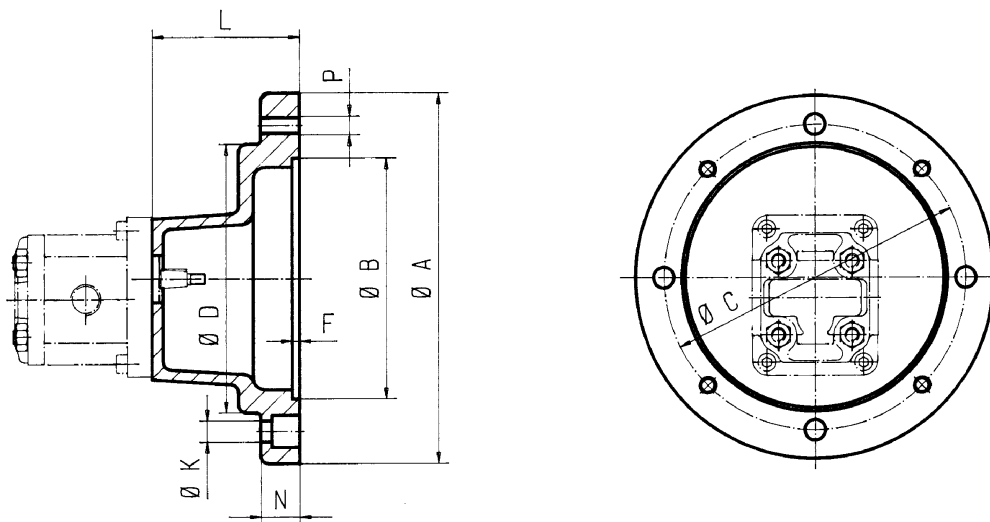

Bell housing with ventilation or leakage hole on request

Type	Motor size	A	B	C	D	F	K	L	N	P	Bell housing weight	Coupling size
Z0/160/70	71	160	110	130	110	4	9	70	8	M8	0.6 kg	RA19 – K16/10-Z25/14
Z0/200/80	80	200	130	165	145	4	11	80	21	M10	0.9 kg	RA19 – K16/10-Z25/14
Z0/200/90	90	200	130	165	145	4	11	90	31	M10	1.0 kg	RA19/24 – K16/10-Z25/14
Z0/250/104	100/112	250	180	215	190	5	14	104	21	M12	1.7 kg	RA24/28 – K16/10-Z30/28

High Pressure Gear Pumps KP 0

Couplings

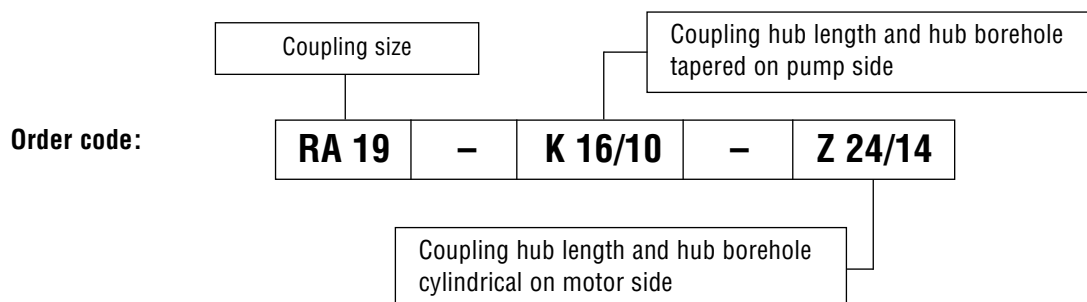
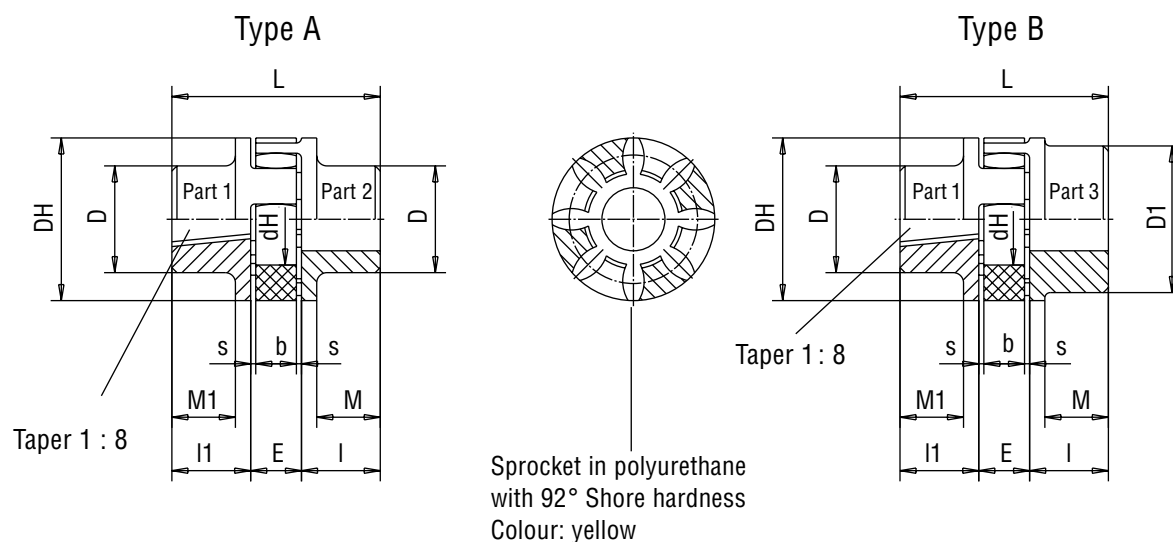

	Coupling size	Weight kg	Mass moment of inertia kgm ²	Initial borehole		Finished borehole				Dimensions								Order code				
				part 2	part 3	min. part 2	min. part 3	max. part 2	max. part 3	l	l ₁	E	s	b	L	M	M ₁		D _H	D	D ₁	d _H
Type A	19	0.12	0.00003	-	-	6	-	19	-	25	17	16	2	12	58	20	11	40	32	-	18	RA 19-K16/10-Z 25/14
	19/24	0.13	0.0004	-	18	-	19	-	24	25	17	16	2	12	58	20	11	40	32	41	18	RA 19/24-K16/10-Z 25/14
Type B	24/28	0.22	0.0001	-	20	-	22	-	28	30	17	18	2	14	65	24	11	56	40	56	27	RA 24/28-K16/10-Z30/28

Operating temperature: -40 °C to +90 °C (brief temperatures up to +120 °C are permissible)

RA: Hub material Al

Weights and Mass moments of inertia refer to max. finished borehole without groove.

Finished borehole according to ISO - Fit H7; Keyways according to DIN 6885 Page 1

High Pressure Gear Pumps KP 0

Pump with motor

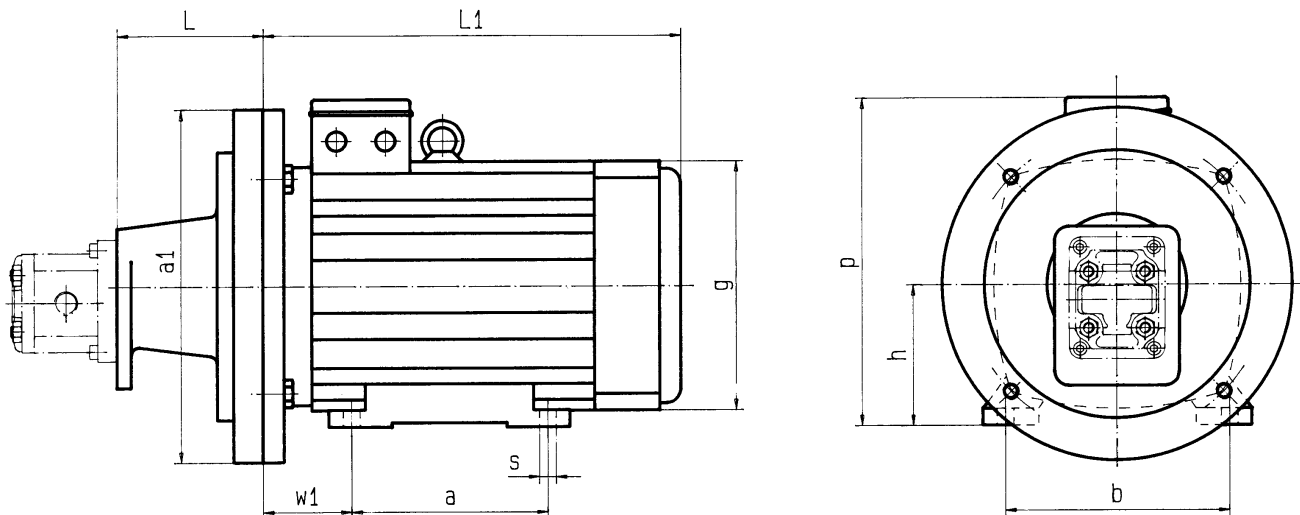

Motor size	Power Motor 4-pole kW	Operating speed rpm	Bell housing	Coupling	Weight	
					E-Motor 4-pole kg	Bell housing kg
71 M4A	0.25	1390	Z0/160/70	RA 19 – K16/10 – Z25/14	7	0.6
71 M4B	0.37	1390			8	
80 M4A	0.55	1400	Z0/200/80	RA 19 – K16/10 – Z25/14	10	0.9
80 M4B	0.75	1400			11	
90 S4A	1.1	1410	Z0/200/90	RA 19/24 – K16/10 – Z25/14	13	1.0
90 L4A	1.5	1420			15	
100 L4A	2.2	1420	Z0/250/104	RA 24/28 – K16/10 – Z30/28	21	1.7
100 L4B	3	1430			24	
112 M4B	4	1440			31	

Motor size	Dimensions in mm									
	L	a ₁	a	b	g	h	L ₁	p	s	w ₁
71	70	160	90	125	138	71	223	182	7	45
80	80	200	100	125	158	80	244	199	10	50
90S	90	200	100	140	193	90	267	218	10	56
90L	90	200	125	140	193	90	267	218	10	56
100	104	250	140	160	217	100	277	237	12	63
112	104	250	140	190	232	112	308	256	12	70

Motor frame sizes are based on Schäfer. Other manufacturers motors can be supplied on request as IMB 35.

Overview of our complete program

Transfer pumps

Transfer pumps for lubricating oil supply equipment, low pressure filling and feed systems, dosing and mixing systems.

Flow measurement

Gear and turbine flow meters and electronics for volume and flow metering technology in hydraulics, processing and laquering technology.

Mobile hydraulics

Single and multistage high pressure gear pumps, hydraulic motors and valves for construction machinery, vehicle-mounted machines.

Industrial hydraulics

Cetop directional control and proportional valves, hydraulic cylinders, pressure, quantity and stop valves for pipe and slab construction, hydraulic accessories for industrial hydraulics (mobile and stationary use).

With our decades of experience, we are at your side, world-wide, for the professional mastery of specific applications and complete solutions in hydraulics and process technology.



KP0/e/01.05