

KRACHT



Pressure Relief Valves

HV, HVF

pilot operated

Construction

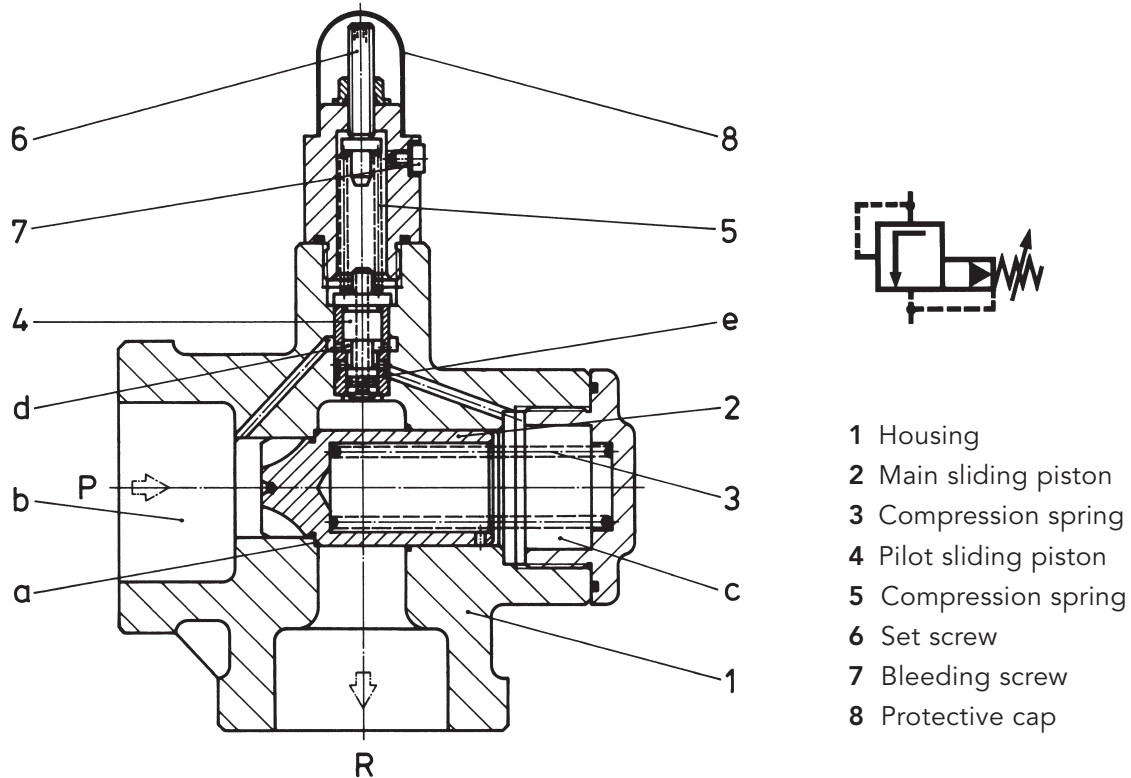

- 1 Housing
- 2 Main sliding piston
- 3 Compression spring
- 4 Pilot sliding piston
- 5 Compression spring
- 6 Set screw
- 7 Bleeding screw
- 8 Protective cap

Description

The pilot operated, sliding piston pressure relief valve HV/HVF is intended for inline mounting and is suitable to safeguard mean pressure hydraulic circuits up to 160 bars. The pipe connection is to be effected either by SAE-Mounting Surfaces (3000 psi) or by Whitworth Pipe Threads "G".

Due to the design principle of sliding piston piloting the valve is also suitable for higher viscosities.

Valve Construction

Main valve stage

The main sliding piston **2** is pressed against the annulated area **a** by the compression spring **3**. The valve chamber **b** located before the main sliding piston **2** as well as the valve chamber **c** to be found behind the main sliding piston **2** are directly connected with the pilot valve.

Pilot valve

The pilot sliding Piston **4** is loaded by the compression spring **5** and is balanced by the operating pressure p acting on the annulated area **d**. As soon as the spring force is exceeded by the operating pressure p the connection behind the main sliding piston **2** is blocked and the valve chamber **c** is then connected with the reservoir via the bore **e** within the pilot sliding piston **4**. In this way it is guaranteed that, as soon as the set pressure is reached, the main sliding Piston **2** releases the oil flow to the reservoir without any vibrations maintaining the operating pressure as adjusted by the set screw **6**. The spring chamber of the pilot valve can be bled by the bleeding screw **7** provided the valve is installed in vertical fitting position i. e. with the pressure setting arrangement up.

Characteristics

General characteristics

Construction	Sliding piston relief valve – pilot operated
Mounting	Inline
Pipe connection	SAE-Flange (3000 psi) Whitworth pipe thread "G"
Dimensions	Pages 6, 8, 9, 10
Weight	Pages 6, 8, 9, 10
Fitting position	Set screw up
Type of pressure setting	mechanical Set screw Knob
Accessories	Welding flange SAE (3000 psi) Page 10
Δp -Q-characteristics	Page 4
Hydraulic fluids	Hydraulic oils acc. to DIN 51 524/25 (other fluids on request)

Hydraulic characteristics

Nominal size			10	25	40	50	80
Max. flow capacity		l/min	50	120	350	500	750
Nom. operating pressure		bar	160	160	160	80	80
Viscosity range	v_{min}	mm ² /s	13	13	13	13	13
	v_{max}	mm ² /s	600	600	600	600	600
Pressure setting ranges	$p_{v min}$	bar	1	1	1	1	1
	$p_{v max}$	bar	160	160	160	80	80
Fluid temperature ranges	$\vartheta_{m min}$	°C	-20	-20	-20	-20	-20
	$\vartheta_{m max}$	°C	80	80	80	80	80
Ambient temperature	$\vartheta_{u min}$	°C	-20	-20	-20	-20	-20
	$\vartheta_{u max}$	°C	60	60	60	60	60

Characteristic Curves $\Delta p = f(Q)$, Viscosity = 34 mm²/s

HV 10

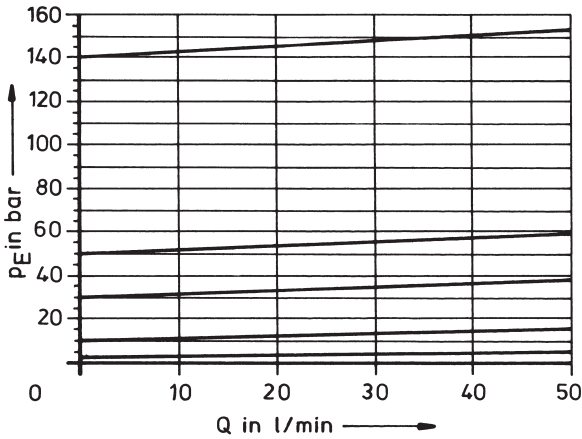

HVF 25

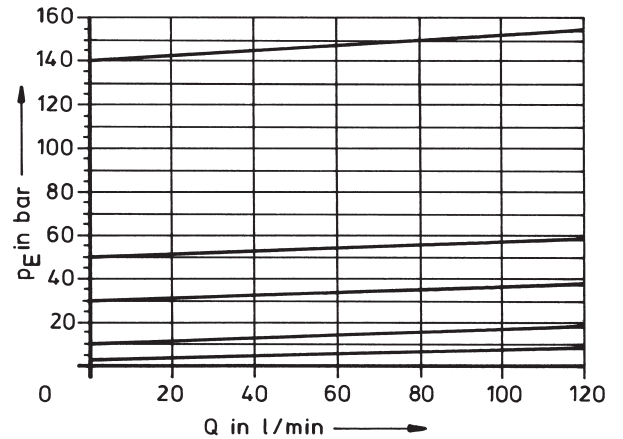

HVF 40

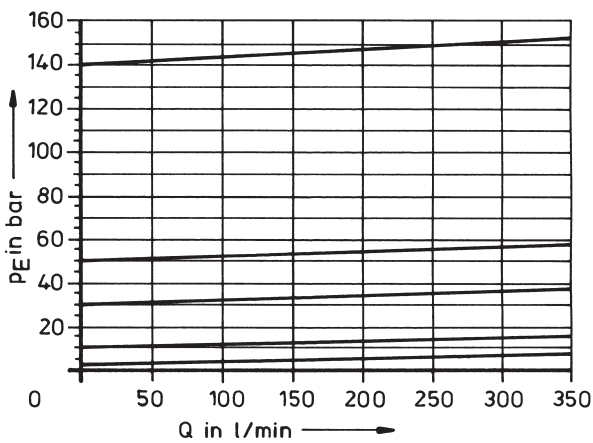

HVF 50

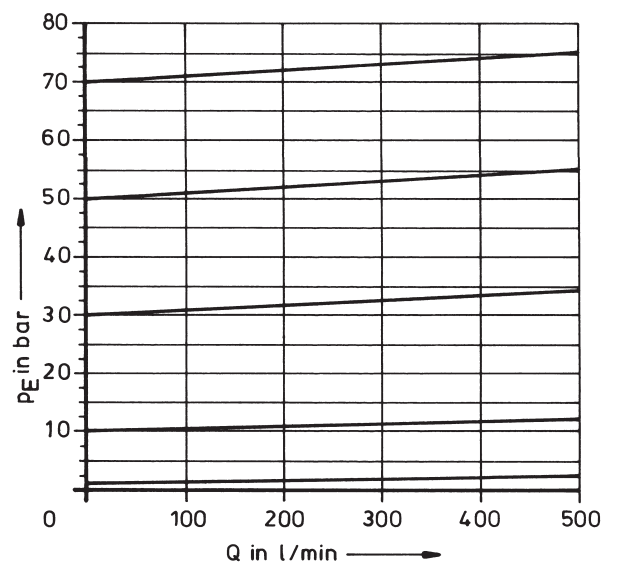

HVF 80

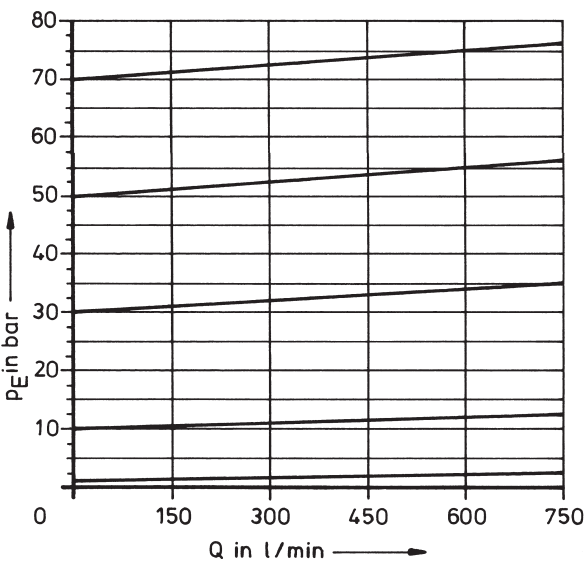

Type Key

Ordering example NG 10

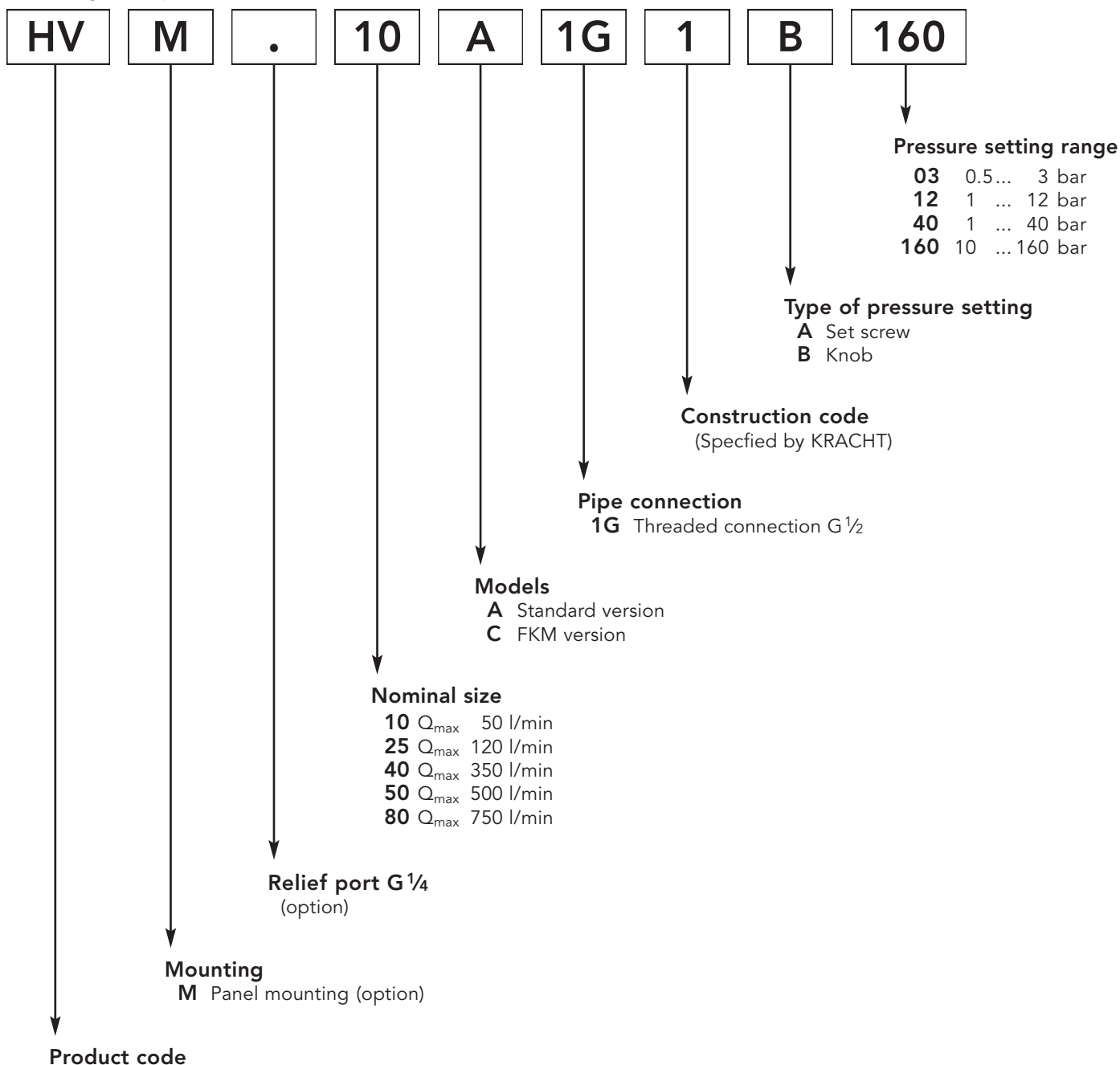

Ordering example: HVM . 10 A 1G 1 B 160

Pressure relief valve, directly spring operated for panel mounting, nominal size 10 (Q_{max} 40 l/min), standard version with threaded connection G 1/2, pressure setting by knob, pressure setting range 10 up to 160 bars

Dimensions

Ordering code HV 10 A 1G 1 A .

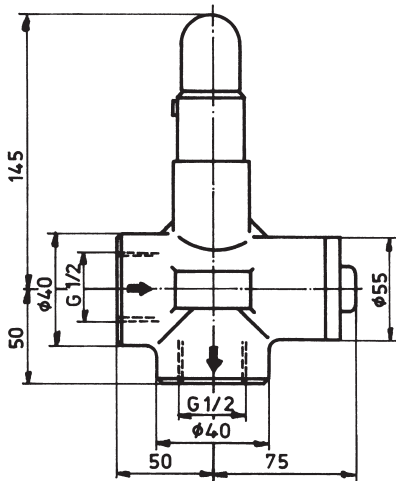

Ordering code HV 10 A 1G 1 B .

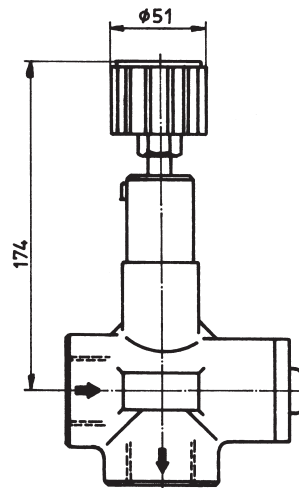

Ordering code HVM 10 A 1G 1 A .

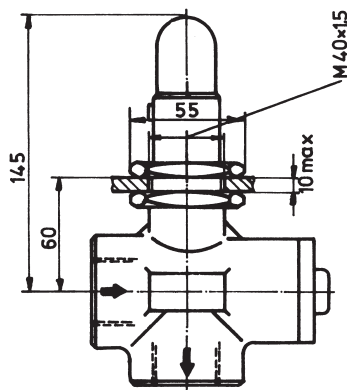

Ordering code HVM 10 A 1G 1 B .

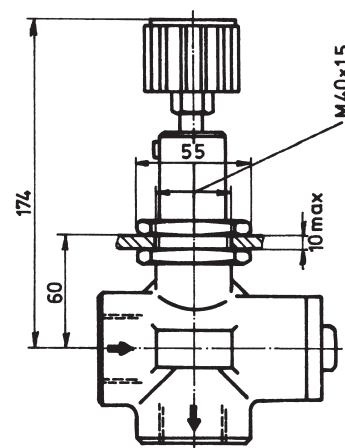

Ordering code HVE 10 A 1G 1 . .
HVME 10 A 1G 1 . .

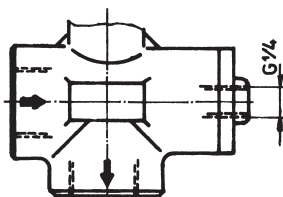

Weight 2.5 kg

Type Key

Ordering example NG 25 ... 80

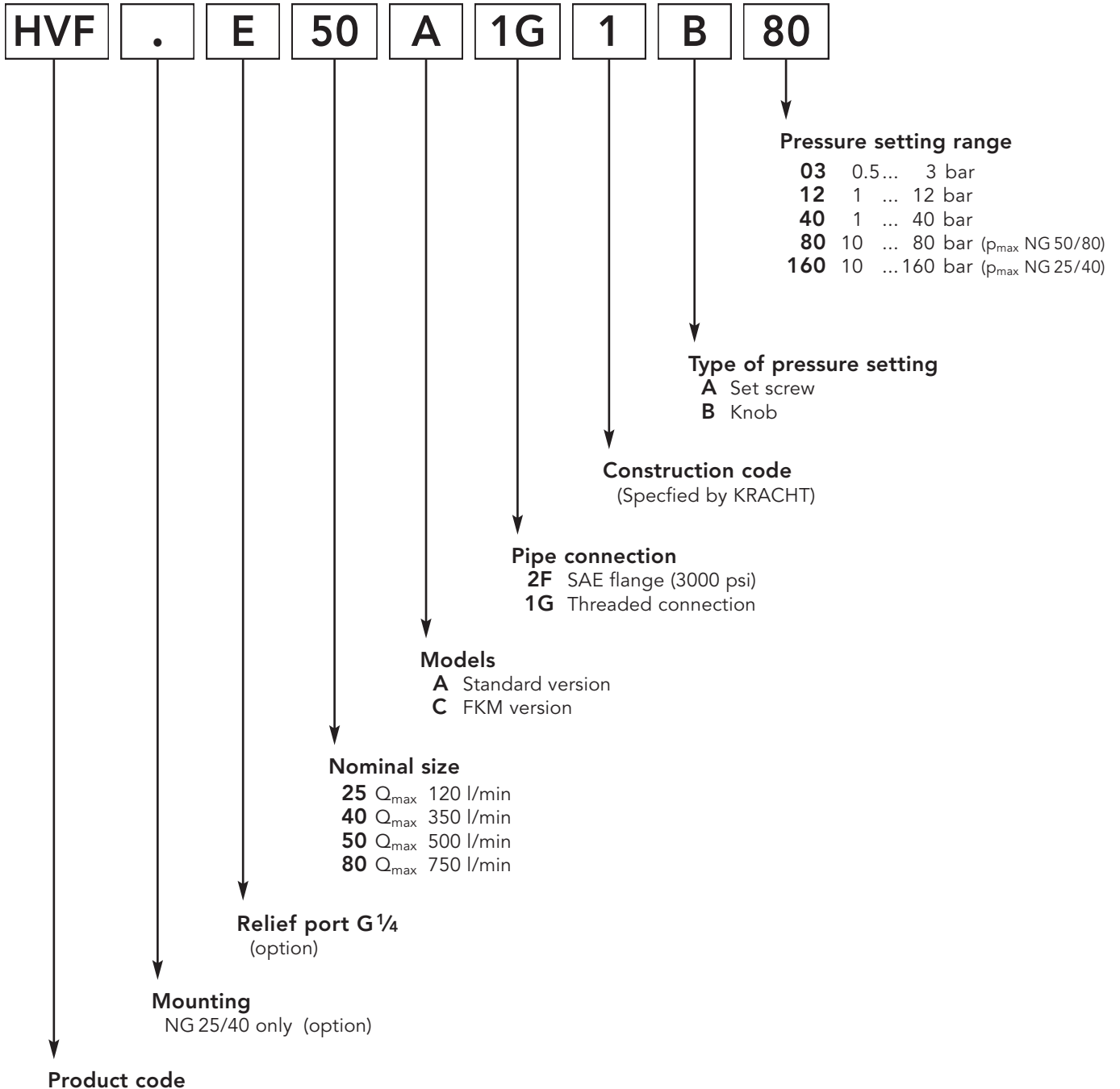

Ordering example: HVF . E 50 A 1G 1 B 80

Pressure relief valve, pilot operated, flange version with relief port G 1/4, nominal size 50 (Q_{max} 500 l/min), standard version with threaded connection, pressure setting by knob, pressure setting range 10 up to 80 bars

Dimensions

Ordering code HVF . . 2F 1 A .

Ordering code HVF . . 1G 1 A .

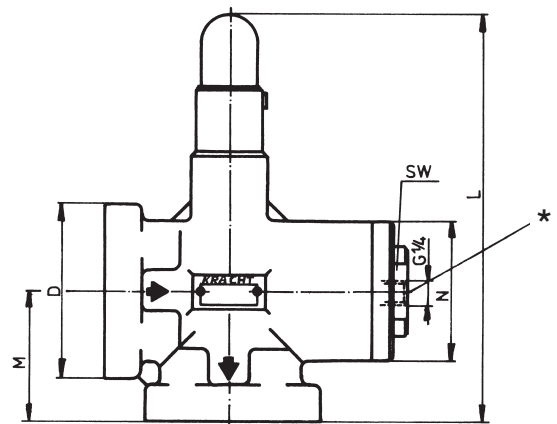
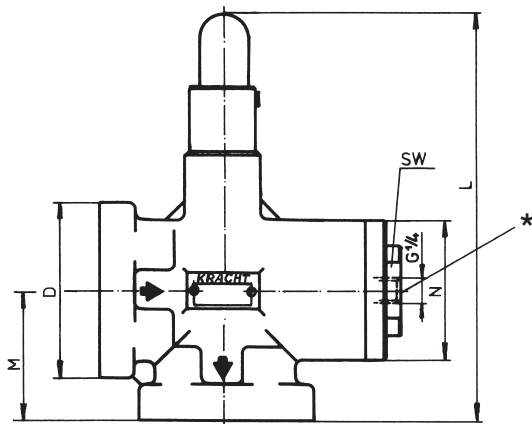
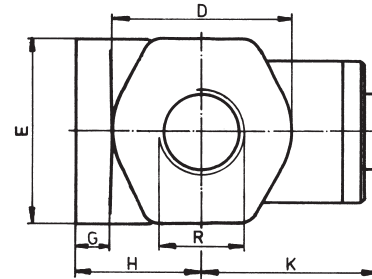
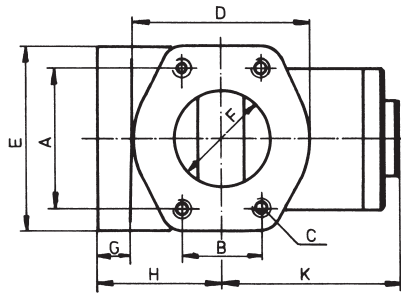

* Relief port for type HVFE

Nom. size	SAE flange	Thread R													Wrench size	Weight kg
			A	B	C	D	E	F	G	H	K	L	M	N		
25	1"	G 1	52.4	26.2	M 10	59	70	26	20	50	75	200	55	Ø 55	24	3.4
40	1½"	G 1½	69.9	35.7	M 12	83	94	39	20	65	95	220	65	Ø 75	36	6.7
50	2"	G 2	77.8	42.9	M 12	97	102	50	20	75	105	240	75	Ø 90	30	10.9
80	3"	G 3	106.4	61.9	M 16	131	135	78	25	110	125	280	110	Ø 105	40	18.1

Dimensions

Ordering code HVF . . 2F 1 B .

Ordering code HVF . . 1G 1 B .

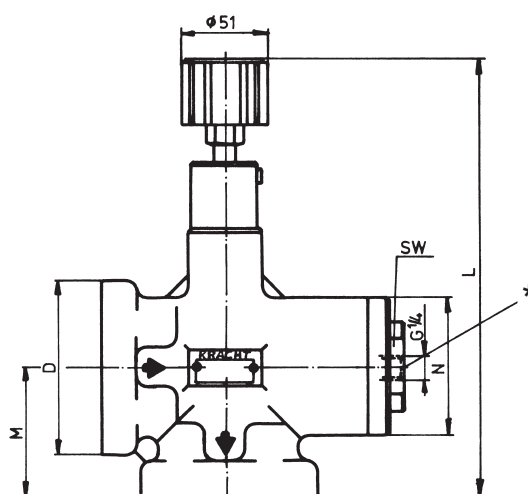
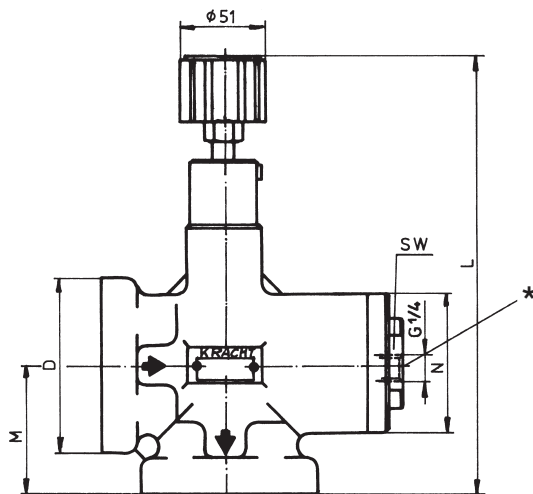
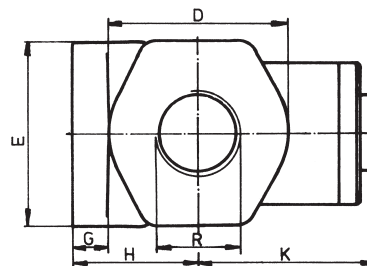
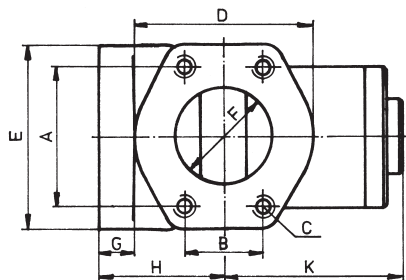

* Relief port for type HVFE

Nom. size	SAE flange	Thread R													Wrench size	Weight kg
			A	B	C	D	E	F	G	H	K	L	M	N		
25	1"	G 1	52.4	26.2	M 10	59	70	26	20	50	75	229	55	Ø 55	24	3.4
40	1½"	G 1½	69.9	35.7	M 12	83	94	39	20	65	95	246	65	Ø 75	36	6.7
50	2"	G 2	77.8	42.9	M 12	97	102	50	20	75	105	266	75	Ø 90	30	10.9
80	3"	G 3	106.4	61.9	M 16	131	135	78	25	110	125	306	110	Ø 105	40	18.1

Dimensions

Ordering code HVFM . . 2F 1 A .
HVFM . . 1G 1 A .

Ordering code HVFM . . 2F 1 B .
HVFM . . 1G 1 B .

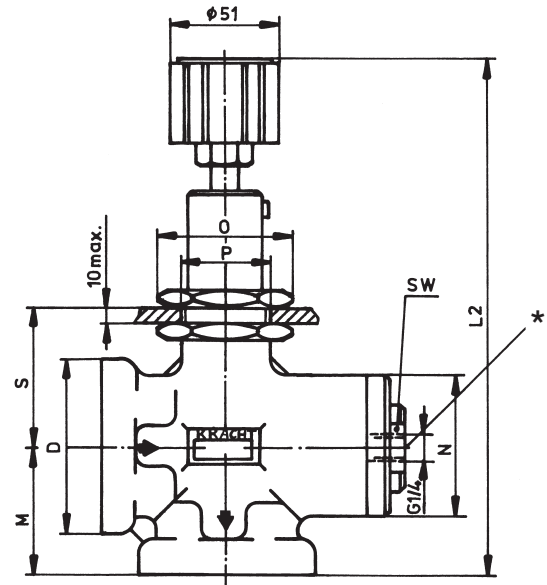
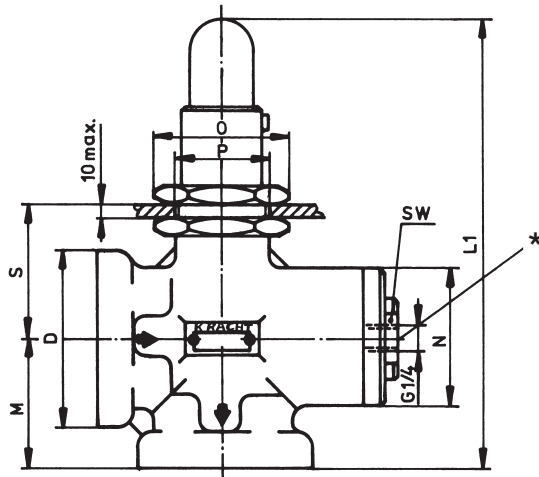

* Relief port for type HVFE

Nom. size	SAE flange	Thread R														Wrench size	P	Weight kg		
			A	B	C	D	E	F	G	H	K	L ₁	L ₂	M	N				O	S
25	1"	G 1	52.4	26.2	M10	59	70	26	20	50	75	200	229	55	Ø55	55	60	24	M 40x15	3.4
40	1½"	G 1½	69.9	35.7	M12	83	94	39	20	65	95	220	246	65	Ø75	55	60	36	M 40x15	6.7

Drawing for dimensions A, B, C, E, F, G, H, K see page 9

Accessories/ Ordering code HVFM 40 A 2F 1 A 60 + 2 x CFS 106-ST

Welding flange SAE (3000 psi)

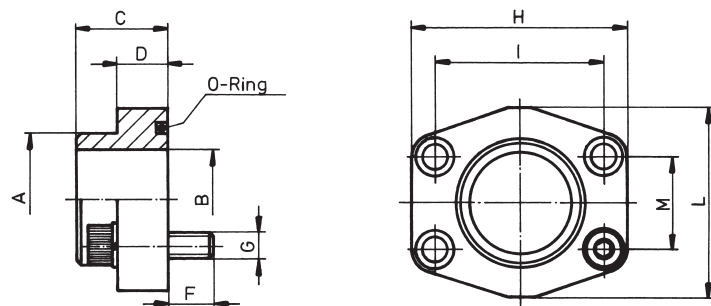

Ordering code	SAE flange												O-Ring	Weight kg
		A	B	C	D	F	G	H	I	L	M			
CFS 102-ST	1"	34.5	25	38	18	14	M 10	71	52.4	53	26.2	4131	0.6	
CFS 106-ST	1½"	48.6	38	44	25	18	M 12	94	70	77	35.7	4187	1.2	
CFS 108-ST	2"	61	50	45	25	18	M 12	103	77.8	89	42.9	4225	1.5	
CFS 112-ST	3"	89	73	50	27	23	M 16	135	106.4	124	62	4337	2.7	

Product Portfolio

Transfer Pumps

Transfer pumps for lubricating oil supply equipment, low pressure filling and feed systems, dosing and mixing systems.

Mobile Hydraulics

Single and multistage high pressure gear pumps, hydraulic motors and valves for construction machinery, vehicle-mounted machines.

Flow Measurement

Gear and turbine flow meters and electronics for volume and flow metering technology in hydraulics, processing and laquering technology.

Industrial Hydraulics / Test Bench Construction

Cetop directional control and proportional valves, hydraulic cylinders, pressure, quantity and stop valves for pipe and slab construction, hydraulic accessories for industrial hydraulics (mobile and stationary use).

Technology Test benches / Fluid Test benches.



HV, HVF/GB/12.07

KRACHT