

KRACHT®

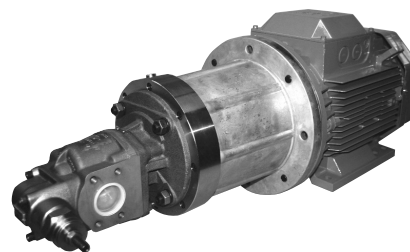

Transfer Gear Pumps

KF 4/125 ... KF 6/730

with magnetic coupling

Construction

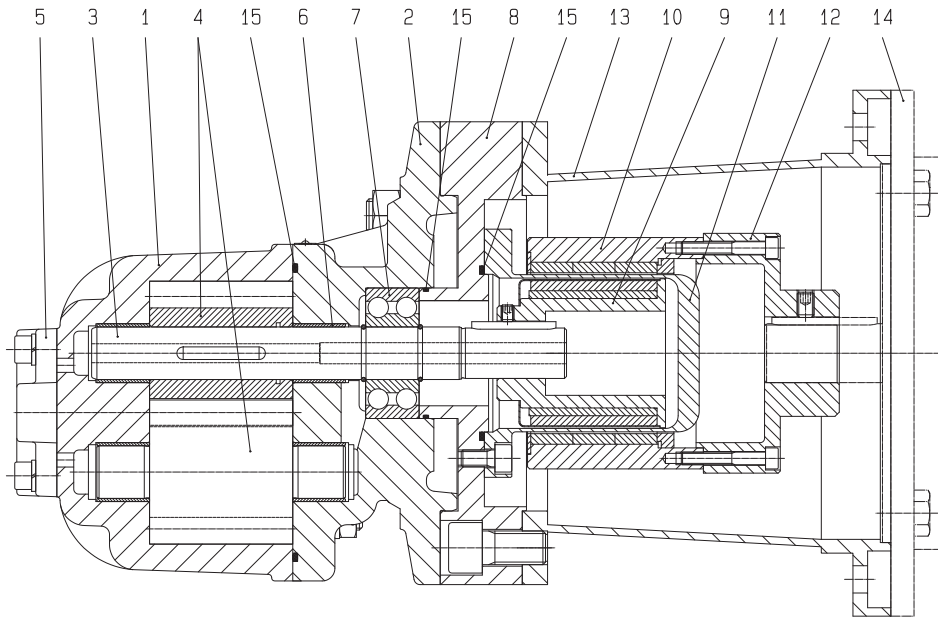

1 Housing	6 Plain bearing bush	11 Split case
2 Flange mounting cover	7 Outboard bearing	12 Flange hub
3 Drive shaft	8 Adapter flange	13 Bell housing
4 Gearing	9 Inner rotor	14 Driven motor
5 End cover	10 Outer rotor	15 O-Ring

Function

Conventional sealing gaskets are pushed to their limits with different applications. Typical applications are found in polyurethane facilities, refrigerating machines and vacuum facilities. For these applications, you have the possibility to equip the KF 4/125... KF 6/730 with a magnetic coupling.

The magnetic coupling serves as a shaft seal and for the transmission of the torque. The outer rotor of the magnetic coupling is assembled on the engine shaft and the inner rotor is assembled directly on the pumping shaft. The torque is transmitted through the magnetic forces between the outer and inner rotor. Between the two rotors, you have the split case which hermetically seals the pump.

The magnetic coupling is used when an absolute sealing is required between the pumping room and the atmosphere, for example, in the case of a dosage of isocyanate, where the contact with air would lead to an unwanted cure of the medium. It can be used in vacuum operation – for example, filling brake fluid – in which an intrusion of air into the system is steadily prevented.

Also, a leak-free operation is ensured when working in closed systems with high pressure on the pump inlet side. The magnetic coupling is predestined for dispensing dangerous and health hazardous mediums.

Materials

Pump	Housing and cover	EN-GJL-250 (GG 25) EN-GJS-400-15 (GGG 40) on request
	Gearing	16 Mn Cr 5
	Bearing bushes	DU (multi-compound plain bearings P 10, DP4) optional Iglidur X
	Seals	EPDM, CR, HNBR, FKM, FEP
Magnetic coupling	Inner rotor	Hub made of stainless steel 1.4571 Magnets made of Sm2Co17 Magnet covering made of stainless steel 1.4571
	Split case	Flange made of stainless steel 1.4571 Pod made of stainless steel 1.4571 (From construction size 75; alternatively of Hastelloy In ceramics (ZrO2MgO) on request)
	Outer rotor	Hub made of 355J2G3 (St 52) Magnet made of Sm2Co17 or NdFeB

General Characteristics

Fixing type	flange
Connection type	flanged connection, welding connection, threaded connection
Direction of rotation	clockwise or anticlockwise
Mounting position	horizontal, vertikal (shaft end facing downward)

Working Characteristics

Nominal sizes	$V_g =$	125 / 150 / 180 / 200 / 250 / 315 / 400 / 500 / 630 / 730 cm ³ /r
Working pressure Inlet port	Working	$p_{e \min}$ -0.4 bar / -5.8 psi, vacuum facility -0.92 bar / -13.3 psi $p_{e \max}$ 16 bar / 232 psi (1) $p_{e \max}$ 25 bar / 363 psi (2) $p_{e \max}$ 40 bar / 580 psi (3)
	Standstill	$p_{e \min}$ -1 bar / -15 psi $p_{e \max}$ 16 bar / 232 psi (1) $p_{e \max}$ 25 bar / 363 psi (2) $p_{e \max}$ 40 bar / 580 psi (3)
Pressures > 25 bar / 363 psi only after release by the KRACHT GmbH.		
Speed	n_{\min} = n_{\max} =	200 1/min 2 000 1/min
Viscosity	v_{\min} = v_{\min} = v_{\max} =	12 cSt 4 cSt (Special version for low viscose medias) 8 000 cSt
Media temperature pump	$\vartheta_{m \min}$ = $\vartheta_{m \max}$ = $\vartheta_{m \max}$ = $\vartheta_{m \max}$ = $\vartheta_{m \max}$ = $\vartheta_{m \max}$ =	-10 °C / 14 °F 120 °C / 248 °F (EPDM) 100 °C / 212 °F (CR) 100 °C / 212 °F (HNBR) 150 °C / 302 °F (FKM) 200 °C / 392 °F (FEP)
Media temperature magnetic coupling	$\vartheta_{m \max}$ = $\vartheta_{m \max}$ =	150 °C / 302 °F magnet material NdFeB 300 °C / 572 °F magnet material Sm2Co17
Ambient temperature	$\vartheta_{u \min}$ = $\vartheta_{u \max}$ =	-20 °C / -4 °F 60 °C / 140 °F

Technical Data

Pump	Nominal size	Geom. displacement V_g cm ³ /r	Working pressure p_b bar / psi	Max. pressure $p_{\max.}$ bar / psi	Speed range	
					n_{\min} 1/min	n_{\max} 1/min
4 / ...	125	129	25 / 363	40 / 580	200	2000
	150	153	25 / 363	30 / 435		
	180	184	25 / 363	25 / 363		
5 / ...	200	204	25 / 363	30 / 435		
	250	255	20 / 290	25 / 363		
	315	321	16 / 232	20 / 290		
6 / ...	400	405	25 / 363	30 / 435	200	1500
	500	505	20 / 290	25 / 363		
	630	629	16 / 232	20 / 290		
	730	730	14 / 203	16 / 232		

Selection Assistance

Pump	Coupling size	Stat. cut-off torque at 20 °C / 68 °F (Nm)	Permitted power consumption (kW) at n = 750 1/min	Motor size	Permitted power consumption (kW) at n = 950 1/min	Motor size	Permitted power consumption (kW) at n = 1450 1/min	Motor size
KF 4/...	MSC 75	40	1.5	112	2.2	112	3 4	100 112
	MSC 110	95	4 5.5	160 160	5.5 7.5	132 160	7.5 11	132 160
	MSC 135	145	7.5	160	11	160	15 18.5	160 180
KF 5/...	MSB 110	60	3	132	4	132	5.5	132
	MSC 110	95	4 5.5	160 160	5.5 7.5	132 160	7.5 11	132 160
	MSC 135	145	7.5	160	11	160	15 18.5	160 180
	MSD 135	200	11	180	15	180	22	180
KF 6/...	MSC 135	145	7.5	160	11	160	15 18.5	160 180
	MSD 135	200	11	180	15	180	15 18.5	160 180
	MSE 165	370	18.5 22	225 225	30	225	37 45	225 225

The values stated in the table refer to a maximum media temperature of 80 °C / 176 °F. At media temperatures > 80 °C / 176 °F are to be selected if necessary stronger magnetic couplings.

Design of the magnetic coupling

To design the magnetic coupling, the following information needs to be available:

- Pump size
- Pump pressure, working and start-up pressure
- working and starting viscosity
- Precise name of media – required static seals (if possible) – possibly main media characteristics
- Drive motor power
- Speed or speed range
- Switch on type – direct or with frequency inverter, media and ambient temperature

The magnetic coupling should be designed by engineering. Here, the max. start-up torque needs to be considered and the media-specific characteristics in the fluid to be sealed need to be complied with. The split case implementation on the housing and the interior rotor on the shaft are then made based on the structural circumstances and expected number of pieces.

Improper design of the sensitive seal/torque transmission system can lead to irreparable damage.

Do not mix up magnetic coupling with a Rotex coupling!

Torque reduction with temperature increase

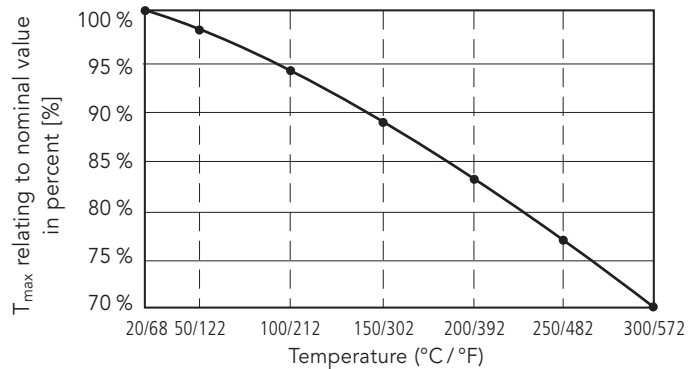

Torque reduction with increased temperature for SmCo magnets on internal and external rotor.

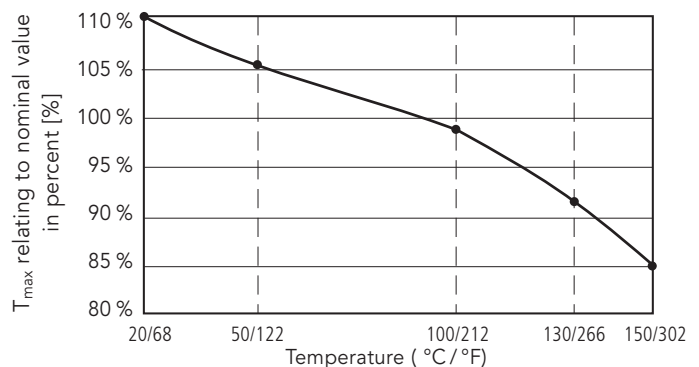

Torque reduction with increased temperature for SmCo magnets on internal rotor, NdFeB magnets on external rotor.

Type Key

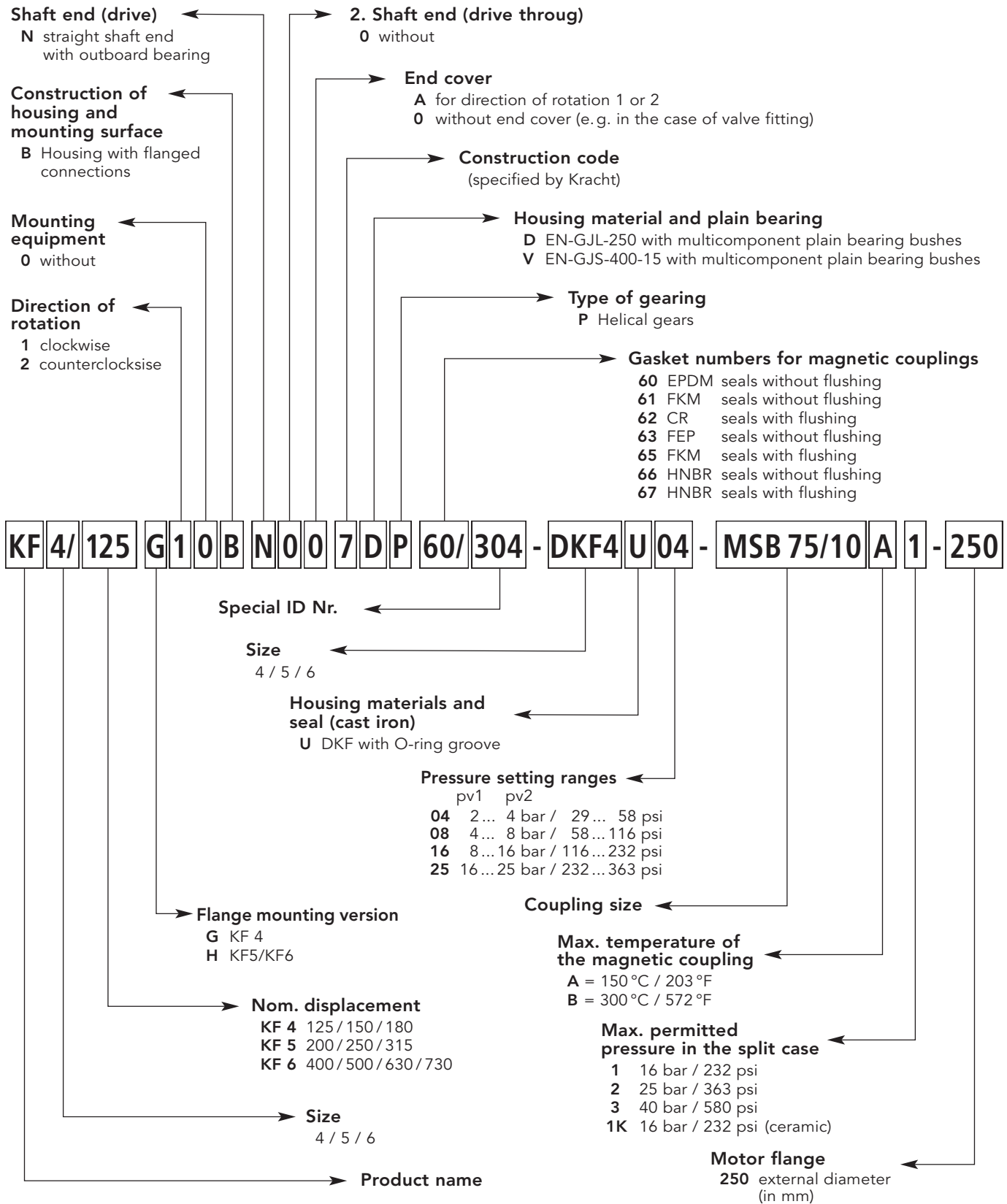

Accessories Connection Flanges

Welding connector KF 4

Ordering example

2 pieces welding connector KF 4

complete welding connector with gasket and screws for the size KF 4

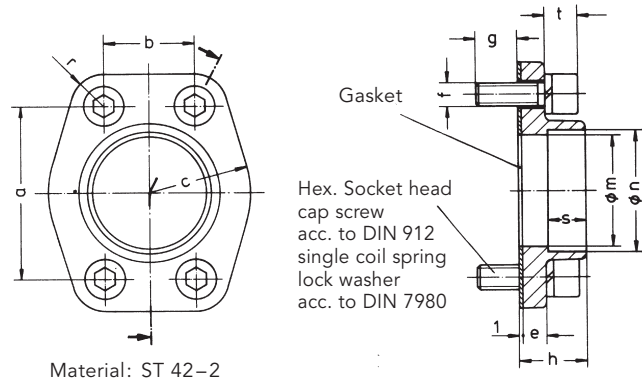

Material: ST 42-2

Welding connector KF 5, KF 6

Ordering example

2 pieces welding connector KF 5

complete welding connector with gasket and screws for the size KF 5 / 250

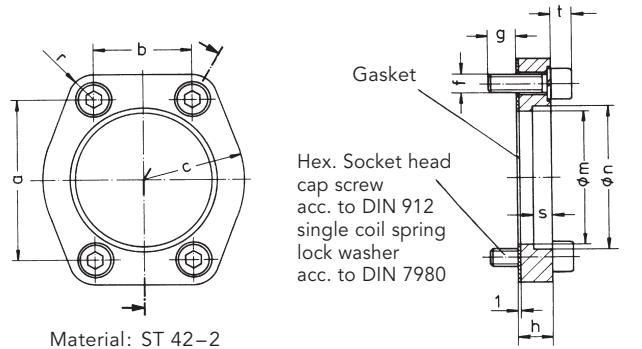

Material: ST 42-2

Size	Nom-displacement	a	b	c	e	f	g	h	m	n	r	s	t	Screws DIN 912-8.8	Nom-size	Pipe external Ø	Weight
		Dimensions in mm															kg
KF 4		77.8	42.9	50	9	M12	17	26	57	61	13	15	-	M12x30	50	60.3	0.63
KF 5 / 200		88.9	50.8	55	-	M12	16	18	68	77	15	12	12	M12x35	65	76.1	0.86
KF 5 / 250 / 315		106.4	61.9	65	-	M12	16	18	82	90	15	12	12	M12x35	80	88.9	1.2
KF 6		130.2	77.8	80	-	M16	24	24	107	115.3	20	15	20	M16x50	100	114.3	2.5
		Dimensions in inch															lb
KF 4		3.06	1.69	1.97	0.35	M12	0.67	1.02	2.24	2.4	0.51	0.59	-	M12x1.18	50	2.37	1.39
KF 5 / 200		3.5	2.0	2.17	-	M12	0.63	0.71	2.68	3.03	0.59	0.47	0.47	M12x1.38	65	3.0	1.9
KF 5 / 250 / 315		4.19	2.44	2.56	-	M12	0.63	0.71	3.23	3.54	0.59	0.47	0.47	M12x1.38	80	3.5	2.65
KF 6		5.13	3.06	3.15	-	M16	0.94	0.94	4.21	4.54	0.79	0.59	0.79	M16x1.97	100	4.5	5.51

Welding connector KF 4

Ordering example

2 pieces welding connector KF 4

complete welding connector with gasket and screws for the size KF 4

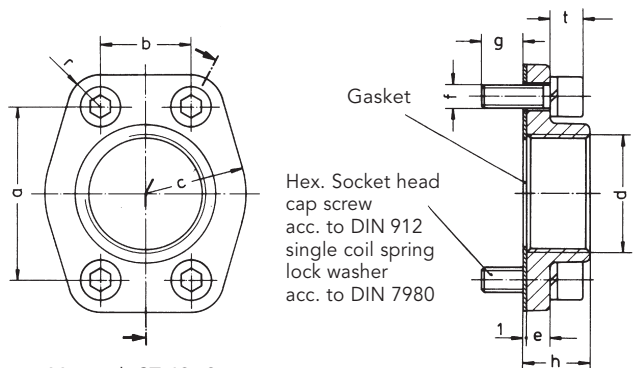

Material: ST 42-2

Product Portfolio

Transfer Pumps

Transfer pumps for lubricating oil supply equipment, low pressure filling and feed systems, dosing and mixing systems.

Mobile Hydraulics

Single and multistage high pressure gear pumps, hydraulic motors and valves for construction machinery, vehicle-mounted machines.

Flow Measurement

Gear and turbine flow meters and electronics for volume and flow metering technology in hydraulics, processing and laquering technology.

Industrial Hydraulics / Test Bench Construction

Cetop directional control and proportional valves, hydraulic cylinders, pressure, quantity and stop valves for pipe and slab construction, hydraulic accessories for industrial hydraulics (mobile and stationary use).

Technology Test benches / Fluid Test benches.



KF4/125-KF6/730 with magn. coupl./USA/08.11

KRACHT®