

# Nidec

All for dreams



艾默生CT一级代理商及全国联保维修中心，联系电话：021-51093390



## User Guide

# Mentor MP

*High performance DC drive  
25A to 7400A, 480V to 690V  
Two or four quadrant operation*

Part Number: 0476-0000-07

Issue: 7

**CONTROL TECHNIQUES™**

## Original Instructions

For the purposes of compliance with the EU Machinery Directive 2006/42/EC, the English version of this manual is the Original Instructions. Manuals in other languages are Translations of the Original Instructions.

### Documentation

Manuals are available to download from the following locations: <http://www.drive-setup.com/ctdownloads>

The information contained in this manual is believed to be correct at the time of printing and does not form part of any contract. The manufacturer reserves the right to change the specification of the product and its performance, and the contents of the manual, without notice.

### Warranty and Liability

In no event and under no circumstances shall the manufacturer be liable for damages and failures due to misuse, abuse, improper installation, or abnormal conditions of temperature, dust, or corrosion, or failures due to operation outside the published ratings. The manufacturer is not liable for consequential and incidental damages. Contact the supplier of the dive for full details of the warranty terms.

### Environmental policy

Control Techniques Ltd operates an Environmental Management System (EMS) that conforms to the International Standard ISO 14001.

Further information on our Environmental Policy can be found at: <http://www.drive-setup.com/environment>

### Restriction of Hazardous Substances (RoHS)

The products covered by this manual comply with European and International regulations on the Restriction of Hazardous Substances including EU directive 2011/65/EU and the Chinese Administrative Measures for Restriction of Hazardous Substances in Electrical and Electronic Products.

### Disposal and Recycling (WEEE)



When electronic products reach the end of their useful life, they must not be disposed of along with domestic waste but should be recycled by a specialist recycler of electronic equipment. Control Techniques products are designed to be easily dismantled into their major component parts for efficient recycling. The majority of materials used in the product are suitable for recycling.

Product packaging is of good quality and can be re-used. Large products are packed in wooden crates. Smaller products are packaged in strong cardboard cartons which have a high recycled fibre content. Cartons can be re-used and recycled. Polythene, used in protective film and bags for wrapping the product, can be recycled. When preparing to recycle or dispose of any product or packaging, please observe local legislation and best practice.

### REACH legislation

EC Regulation 1907/2006 on the Registration, Evaluation, Authorisation and restriction of Chemicals (REACH) requires the supplier of an article to inform the recipient if it contains more than a specified proportion of any substance which is considered by the European Chemicals Agency (ECHA) to be a Substance of Very High Concern (SVHC) and is therefore listed by them as a candidate for compulsory authorisation.

Further information on our compliance with REACH can be found at: <http://www.drive-setup.com/reach>

### Registered Office

#### Nidec Control Techniques Ltd

The Gro

Newtown

Powys

SY16 3BE

UK

Registered in England and Wales. Company Reg. No. 01236886.

### Copyright

The contents of this publication are believed to be correct at the time of printing. In the interests of a commitment to a policy of continuous development and improvement, the manufacturer reserves the right to change the specification of the product or its performance, or the contents of the guide, without notice.

All rights reserved. No parts of this guide may be reproduced or transmitted in any form or by any means, electrical or mechanical including photocopying, recording or by an information storage or retrieval system, without permission in writing from the publisher.

Copyright © November 2017 Nidec Control Techniques Ltd

---

# Contents

---

<b>1</b>	<b>Safety Information</b>	<b>6</b>	<b>5</b>	<b>Getting started</b>	<b>62</b>
1.1	Warnings, Cautions and Notes	6	5.1	Understanding the display	62
1.2	Important safety information. Hazards. Competence of designers and installers	6	5.2	Keypad operation	62
1.3	Responsibility	6	5.3	Menu 0 (sub block)	64
1.4	Compliance with regulations	6	5.4	Pre-defined sub blocks	65
1.5	Electrical hazards	6	5.5	Menu 0 (linear)	66
1.6	Stored electrical charge	6	5.6	Menu structure	66
1.7	Mechanical hazards	6	5.7	Advanced menus	67
1.8	Access to equipment	6	5.8	Saving parameters	67
1.9	Environmental limits	6	5.9	Restoring parameter defaults	67
1.10	Hazardous environments	6	5.10	Differences between European and USA defaults	68
1.11	Motor	7	5.11	Displaying parameters with non-default values only	68
1.12	Mechanical brake control	7	5.12	Displaying destination parameters only	68
1.13	Adjusting parameters	7	5.13	Parameter access level and security	68
1.14	Electromagnetic compatibility (EMC)	7	5.14	Serial communications	69
<b>2</b>	<b>Product information</b>	<b>8</b>	<b>6</b>	<b>Basic parameters</b>	<b>70</b>
2.1	Drive firmware version	8	6.1	Full descriptions	71
2.2	Current ratings	8	<b>7</b>	<b>Running the motor</b>	<b>79</b>
2.3	Model number	9	7.1	Quick start commissioning / start-up (from European defaults)	80
2.4	Compatible encoders	10	7.2	Quick start commissioning / start-up (from USA defaults)	82
2.5	Nameplate description	10	7.3	CTSoft software commissioning / start-up tool	83
2.6	Drive features and options	11	7.4	Setting up a feedback device	84
2.7	Items supplied with the drive	14	<b>8</b>	<b>Optimization</b>	<b>85</b>
<b>3</b>	<b>Mechanical Installation</b>	<b>15</b>	8.1	Armature current	85
3.1	Safety	15	8.2	Speed feedback	85
3.2	Planning the installation	15	8.3	Field current	85
3.3	Terminal cover removal	16	8.4	Current loop gains self-tuning	85
3.4	Mounting method	19	8.5	Speed loop gains tuning	86
3.5	Installing and removing the terminal shrouds	27	8.6	Current limit tapers	87
3.6	Enclosure	29	<b>9</b>	<b>SMARTCARD operation</b>	<b>88</b>
3.7	Heatsink fan operation	30	9.1	Introduction	88
3.8	IP rating (Ingress Protection)	30	9.2	Easy saving and reading	88
3.9	Electrical terminals	31	9.3	Transferring data	88
3.10	Routine maintenance	34	9.4	Data block header information	90
<b>4</b>	<b>Electrical installation</b>	<b>35</b>	9.5	SMARTCARD parameters	90
4.1	Electrical connections	36	9.6	SMARTCARD trips	91
4.2	Ground connections	39	<b>10</b>	<b>Onboard PLC</b>	<b>93</b>
4.3	AC supply requirements	40	10.1	Onboard PLC and SYPT Lite	93
4.4	Line reactors	41	10.2	Benefits	93
4.5	Control 24 Vdc supply	42	10.3	Limitations	93
4.6	Cable and fuse size ratings	42	10.4	Getting started	94
4.7	External suppressor resistor	50	10.5	Onboard PLC parameters	94
4.8	Ground leakage	52	10.6	Onboard PLC trips	95
4.9	EMC (Electromagnetic compatibility)	52	10.7	Onboard PLC and the SMARTCARD	95
4.10	Serial communications connections	54			
4.11	Shield connections	55			
4.12	Connecting the fan on size 2C and 2D drives	55			
4.13	Control connections	56			
4.14	General	57			
4.15	Connecting an encoder	60			

<b>11</b>	<b>Advanced parameters</b>	<b>96</b>
11.1	Menu 1: Speed reference	102
11.2	Menu 2: Ramps	106
11.3	Menu 3: Speed feedback and speed control	109
11.4	Menu 4: Torque and current control	112
11.5	Menu 5: Motor and field control	116
11.6	Menu 6: Sequencer and clock	121
11.7	Menu 7: Analog I/O	123
11.8	Menu 8: Digital I/O	125
11.9	Menu 9: Programmable logic, motorized pot and binary sum	129
11.10	Menu 10: Status and trips	132
11.11	Menu 11: General drive set-up	133
11.12	Menu 12: Threshold detectors, variable selectors and brake control function	134
11.13	Menu 13: Position control	140
11.14	Menu 14: User PID controller	144
11.15	Menus 15, 16 and 17: Solutions Module slots	147
11.16	Menu 18: Application menu 1	148
11.17	Menu 19: Application menu 2	148
11.18	Menu 20: Application menu 3	148
11.19	Menu 21: Second motor parameters	149
11.20	Menu 22: Additional Menu 0 set-up	149
11.21	Menu 23: Header selections	149
<b>12</b>	<b>Technical data</b>	<b>150</b>
12.1	Drive technical data	150
12.2	Cable and fuse size ratings	156
12.3	Optional external EMC filters	180
<b>13</b>	<b>Diagnostics</b>	<b>181</b>
13.1	Trip indications	181
13.2	Trip categories	189
13.3	Alarm indications	189
13.4	Status indications	189
13.5	Displaying the trip history	190
13.6	Behaviour of the drive when tripped	190
13.7	Trip masking	190
<b>14</b>	<b>UL information</b>	<b>191</b>
14.1	Common UL Information	191
14.2	AC supply specification	191
14.3	Maximum ratings	191
14.4	Parallel operation	191
14.5	Safety label	191
14.6	UL Listed accessories	191



# EU Declaration of Conformity

**Nidec Control Techniques Ltd**  
**The Gro**  
**Newtown**  
**Powys**  
**UK**  
**SY16 3BE**

This declaration is issued under the sole responsibility of the manufacturer. The object of the declaration is in conformity with the relevant Union harmonization legislation. The declaration applies to the variable speed drive products shown below:

Voltage rating			Frame
480 V	575 V	690 V	
MP25A4(R), MP45A4(R), MP75A4(R)	MP25A5(R), MP45A5(R), MP75A5(R)		1A
MP105A4(R), MP155A4(R), MP210A4(R)	MP105A5(R), MP155A5(R), MP210A5(R)		1B
MP350A4(R), MP420A4(R), MP550A4(R)	MP350A5(R), MP470A5(R)	MP350A6(R), MP470A6(R)	2A
MP700A4(R), MP825A4(R), MP900A4(R)	MP700A5(R), MP825A5(R)	MP700A6(R), MP825A6(R)	2B
MP1200A4, MP1850A4	MP1200A5, MP1850A5	MP1200A6, MP1850A6	2C
MP1200A4R, MP1850A4R	MP1200A5R, MP1850A5R	MP1200A6R, MP1850A6R	2D

The model number may be followed by additional characters that do not affect the ratings.

The variable speed drive products listed above have been designed and manufactured in accordance with the following European harmonized standards:

EN 61800-5-1:2007	Adjustable speed electrical power drive systems - Part 5-1: Safety requirements - Electrical, thermal and energy
EN 61800-3: 2004+A1:2012	Adjustable speed electrical power drive systems - Part 3: EMC requirements and specific test methods
EN 61000-6-2:2005	Electromagnetic compatibility (EMC) - Part 6-2: Generic standards - Immunity for industrial environments
EN 61000-6-4: 2007+ A1:2011	Electromagnetic compatibility (EMC) - Part 6-4: Generic standards - Emission standard for industrial environments
EN 61000-3-2:2014	Electromagnetic compatibility (EMC) - Part 3-2: Limits for harmonic current emissions (equipment input current $\leq 16$ A per phase)
EN 61000-3-3:2013	Electromagnetic compatibility (EMC) - Part 3-3: Limitation of voltage changes, voltage fluctuations and flicker in public, low voltage supply systems, for equipment with rated current $\leq 16$ A per phase and not subject to conditional connection

EN 61000-3-2:2014 Applicable where input current  $< 16$  A. No limits apply for professional equipment where input power  $\geq 1$  kW.

These products comply with the Restriction of Hazardous Substances Directive (2011/65/EU), the Low Voltage Directive (2014/35/EU) and the Electromagnetic Compatibility Directive (2014/30/EU).




**G Williams**  
**Vice President, Technology**  
**Date: 17th March 2016**

**These electronic drive products are intended to be used with appropriate motors, controllers, electrical protection components and other equipment to form complete end products or systems. Compliance with safety and EMC regulations depends upon installing and configuring drives correctly, including using the specified input filters.**

**The drives must be installed only by professional installers who are familiar with requirements for safety and EMC. Refer to the Product Documentation. An EMC data sheet is available giving detailed information. The assembler is responsible for ensuring that the end product or system complies with all the relevant laws in the country where it is to be used.**


# 1 Safety Information

## 1.1 Warnings, Cautions and Notes



A Warning contains information which is essential for avoiding a safety hazard.

**WARNING**



A Caution contains information which is necessary for avoiding a risk of damage to the product or other equipment.

**CAUTION**

### NOTE

A Note contains information which helps to ensure correct operation of the product.

## 1.2 Important safety information. Hazards. Competence of designers and installers

This guide applies to products which control electric motors either directly (drives) or indirectly (controllers, option modules and other auxiliary equipment and accessories). In all cases the hazards associated with powerful electrical drives are present, and all safety information relating to drives and associated equipment must be observed.

Specific warnings are given at the relevant places in this guide.

Drives and controllers are intended as components for professional incorporation into complete systems. If installed incorrectly they may present a safety hazard. The drive uses high voltages and currents, carries a high level of stored electrical energy, and is used to control equipment which can cause injury. Close attention is required to the electrical installation and the system design to avoid hazards either in normal operation or in the event of equipment malfunction. System design, installation, commissioning/start-up and maintenance must be carried out by personnel who have the necessary training and competence. They must read this safety information and this guide carefully.

## 1.3 Responsibility

It is the responsibility of the installer to ensure that the equipment is installed correctly with regard to all instructions given in this guide. They must give due consideration to the safety of the complete system, so as to avoid the risk of injury both in normal operation and in the event of a fault or of reasonably foreseeable misuse.

The manufacturer accepts no liability for any consequences resulting from inappropriate, negligent or incorrect installation of the equipment.

## 1.4 Compliance with regulations

The installer is responsible for complying with all relevant regulations, such as national wiring regulations, accident prevention regulations and electromagnetic compatibility (EMC) regulations. Particular attention must be given to the cross-sectional areas of conductors, the selection of fuses or other protection, and protective ground (earth) connections.

This guide contains instructions for achieving compliance with specific EMC standards.

All machinery to be supplied within the European Union in which this product is used must comply with the following directives:

2006/42/EC Safety of machinery.

2014/30/EU: Electromagnetic Compatibility.

## 1.5 Electrical hazards

The voltages used in the drive can cause severe electrical shock and/or burns, and could be lethal. Extreme care is necessary at all times when working with or adjacent to the drive. Hazardous voltage may be present in any of the following locations:

- AC and DC supply cables and connections
- Output cables and connections
- Many internal parts of the drive, and external option units

Unless otherwise indicated, control terminals are single insulated and must not be touched.

The supply must be disconnected by an approved electrical isolation device before gaining access to the electrical connections.

The STOP and Safe Torque Off functions of the drive do not isolate dangerous voltages from the output of the drive or from any external option unit.

The drive must be installed in accordance with the instructions given in this guide. Failure to observe the instructions could result in a fire hazard.

## 1.6 Stored electrical charge

The drive contains capacitors that remain charged to a potentially lethal voltage after the AC supply has been disconnected. If the drive has been energized, the AC supply must be isolated at least ten minutes before work may continue.

## 1.7 Mechanical hazards

Careful consideration must be given to the functions of the drive or controller which might result in a hazard, either through their intended behaviour or through incorrect operation due to a fault. In any application where a malfunction of the drive or its control system could lead to or allow damage, loss or injury, a risk analysis must be carried out, and where necessary, further measures taken to reduce the risk - for example, an over-speed protection device in case of failure of the speed control, or a fail-safe mechanical brake in case of loss of motor braking.

**With the sole exception of the Safe Torque Off function, none of the drive functions must be used to ensure safety of personnel, i.e. they must not be used for safety-related functions.**

The Safe Torque Off function may be used in a safety-related application. The system designer is responsible for ensuring that the complete system is safe and designed correctly according to the relevant safety standards.

The design of safety-related control systems must only be done by personnel with the required training and experience. The Safe Torque Off function will only ensure the safety of a machine if it is correctly incorporated into a complete safety system. The system must be subject to a risk assessment to confirm that the residual risk of an unsafe event is at an acceptable level for the application.

## 1.8 Access to equipment

Access must be restricted to authorized personnel only. Safety regulations which apply at the place of use must be complied with.

## 1.9 Environmental limits

Instructions in this guide regarding transport, storage, installation and use of the equipment must be complied with, including the specified environmental limits. This includes temperature, humidity, contamination, shock and vibration. Drives must not be subjected to excessive physical force.

## 1.10 Hazardous environments

The equipment must not be installed in a hazardous environment (i.e. a potentially explosive environment).

## 1.11 Motor

The safety of the motor under variable speed conditions must be ensured.

To avoid the risk of physical injury, do not exceed the maximum specified speed of the motor.

Low speeds may cause the motor to overheat because the cooling fan becomes less effective, causing a fire hazard. The motor should be installed with a protection thermistor. If necessary, an electric forced vent fan should be used.

The values of the motor parameters set in the drive affect the protection of the motor. The default values in the drive must not be relied upon. It is essential that the correct value is entered in the Motor Rated Current parameter.

## 1.12 Mechanical brake control

Any brake control functions are provided to allow well co-ordinated operation of an external brake with the drive. While both hardware and software are designed to high standards of quality and robustness, they are not intended for use as safety functions, i.e. where a fault or failure would result in a risk of injury. In any application where the incorrect operation of the brake release mechanism could result in injury, independent protection devices of proven integrity must also be incorporated.

## 1.13 Adjusting parameters

Some parameters have a profound effect on the operation of the drive. They must not be altered without careful consideration of the impact on the controlled system. Measures must be taken to prevent unwanted changes due to error or tampering.

## 1.14 Electromagnetic compatibility (EMC)

Installation instructions for a range of EMC environments are provided in the relevant Power Installation Guide. If the installation is poorly designed or other equipment does not comply with suitable standards for EMC, the product might cause or suffer from disturbance due to electromagnetic interaction with other equipment. It is the responsibility of the installer to ensure that the equipment or system into which the product is incorporated complies with the relevant EMC legislation in the place of use.

## 2 Product information

### 2.1 Drive firmware version

This product is supplied with the latest firmware version. If this drive is to be connected to an existing system or machine, all drive firmware versions should be verified to confirm the same functionality as drives of the same model already present. This may also apply to drives returned from an Nidec Industrial Automation Service Centre or Repair Centre. If there is any doubt please contact the supplier of the product.

This drive contains two software versions which can be checked by looking at Pr 11.29 (di14/0.49) and Pr 11.34. This takes the form of xx.yy.zz where Pr 11.29 (di14/0.49) displays xx.yy and Pr 11.34 displays zz for the user software. Power software is displayed at Pr 11.56 and takes the form of xx.yy. (e.g. for software version 01.06.00, Pr 11.29 (di14/0.49) = 1.06 and Pr 11.34 displays 0 which is compatible with power software version 01.09, Pr 11.56 = 1.09).

**Table 2-1 Model to frame size cross reference**

Model			Frame
480 V EN/IEC cULus	575 V EN/IEC cULus to 600 V	690 V EN/IEC	
MP25A4(R)	MP25A5(R)		1A
MP45A4(R)	MP45A5(R)		
MP75A4(R)	MP75A5(R)		
MP105A4(R)	MP105A5(R)		1B
MP155A4(R)	MP155A5(R)		
MP210A4(R)	MP210A5(R)		
MP350A4(R)	MP350A5(R)	MP350A6(R)	2A
MP420A4(R)			
	MP470A5(R)	MP470A6(R)	
MP550A4(R)			2B
MP700A4(R)	MP700A5(R)	MP700A6(R)	
MP825A4(R)	MP825A5(R)	MP825A6(R)	
MP900A4(R)			2C
MP1200A4	MP1200A5	MP1200A6	
MP1850A4	MP1850A5	MP1850A6	
MP1200A4R	MP1200A5R	MP1200A6R	2D
MP1850A4R	MP1850A5R	MP1850A6R	

### 2.2 Current ratings

The power ratings for the 480 V, 575 V and 690 V configurations are shown in Table 2-2, Table 2-3 and Table 2-4.

The continuous current ratings given are for a maximum ambient temperature of 40 °C (104 °F) and an altitude of 1000 m. For operation at higher temperatures and altitudes de-rating is required.

For further information see Chapter 12 *Technical data* on page 150.

**Table 2-2 480 V current ratings**

Model	AC input current	DC output current		Typical motor power	
	Continuous A	Continuous A	150 % overload A	@ 400 Vdc kW	@ 500 Vdc hp
				MP25A4(R)	22
MP45A4(R)	40	45	67.5	15	27
MP75A4(R)	67	75	112.5	27	45
MP105A4(R)	94	105	157.5	37.5	60
MP155A4(R)	139	155	232.5	56	90
MP210A4(R)	188	210	315	75	125
MP350A4(R)	295	350	525	125	200
MP420A4(R)	350	420	630	150	250
MP550A4(R)	450	550	825	200	300
MP700A4(R)	585	700	1050	250	400
MP825A4(R)	665	825	1237.5	300	500
MP900A4(R)	725	900	1350	340	550
MP1200A4(R)	1050	1200	1800	450	750
MP1850A4(R)	1570	1850	2775	700	1150

**Table 2-3 575 V current ratings**

Model	AC input current	DC output current		Typical motor power (With Vdc = 630 V)	
	Continuous A	Continuous A	150 % overload A	kW	hp
MP45A5(R)	40	45	67.5	25	33
MP75A5(R)	67	75	112.5	42	56
MP105A5(R)	94	105	157.5	58	78
MP155A5(R)	139	155	232.5	88	115
MP210A5(R)	188	210	315	120	160
MP350A5(R)	295	350	525	195	260
MP470A5(R)	395	470*	705	265	355
MP700A5(R)	585	700	1050	395	530
MP825A5(R)	665	825*	1237.5	465	620
MP1200A5(R)	1050	1200	1800	680	910
MP1850A5(R)	1570	1850	2775	1045	1400

\* For this rating at 575 V, 150 % overload time is 20 s at 40 °C and 30s at 35 °C.

**Table 2-4 690 V current ratings**

Model	AC input current	DC output Current		Typical motor power (With Vdc = 760 V)	
	Continuous A	Continuous A	150 % Overload A	kW	hp
MP470A6(R)	395	470*	705	320	425
MP700A6(R)	585	700	1050	480	640
MP825A6(R)	665	825*	1237.5	650	850
MP1200A6(R)	1050	1200	1800	850	1150
MP1850A6(R)	1570	1850	2775	1300	1750

\* For this rating at 690 V, 150 % overload time is 20 s at 40 °C and 30 s at 35 °C.

#### Maximum continuous input current

The values of maximum continuous input current are given to aid the selection of cables and fuses. These values are stated for worst-case condition.

**NOTE**

For current ratings above 1850 A then parallel connection of the drives is required. However, this function is not implemented on firmware versions V01.05.02 and earlier.

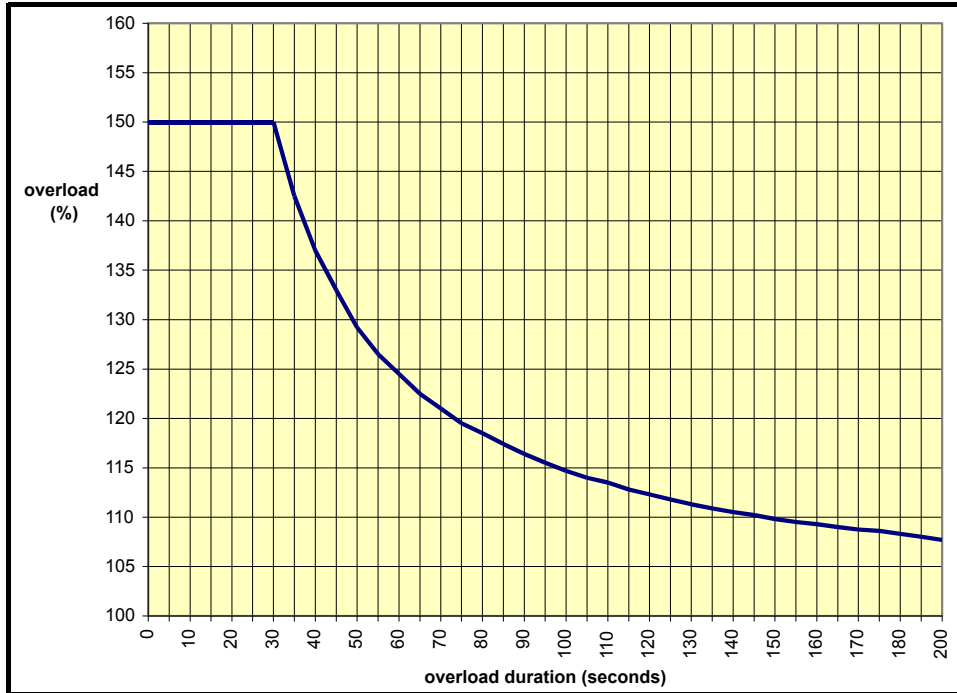
### 2.2.1 Typical short-term overload limits

The maximum percentage overload limit changes depending on the selected motor.

Variations in motor rated current will result in changes in the maximum possible overload as detailed in the *Mentor MP Advanced User Guide*.

Figure 2-1 can be used to determine the maximum overload duration available for overloads between 100 % and 150 %. For example the maximum overload available for a period of 60 seconds is 124 %.

**Figure 2-1 Maximum overload duration available**



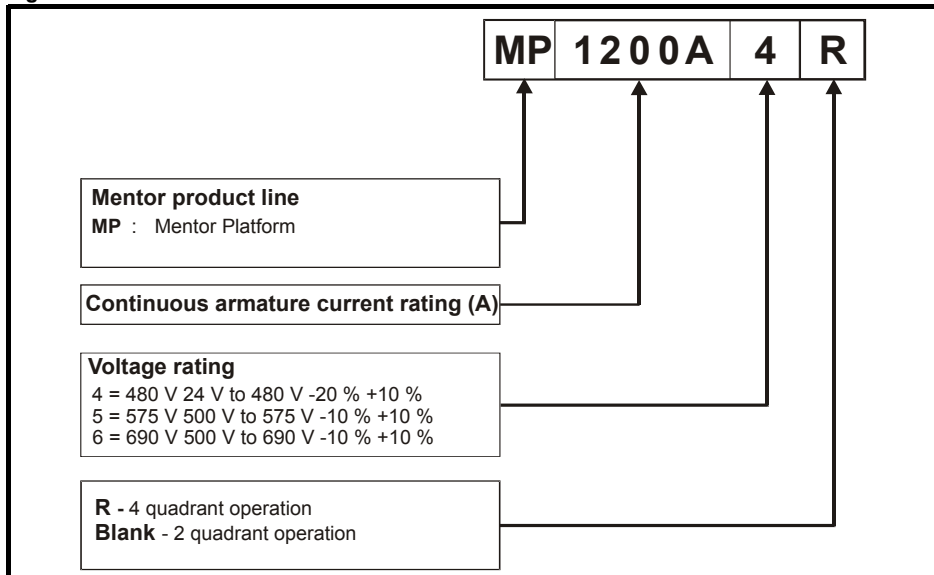
**NOTE**

Overload of 150 % for 30 s is available up to a maximum of 10 repetitions per hour.

### 2.3 Model number

The way in which the model numbers for the Mentor MP range are formed is described in Figure 2-2.

**Figure 2-2 Model number**



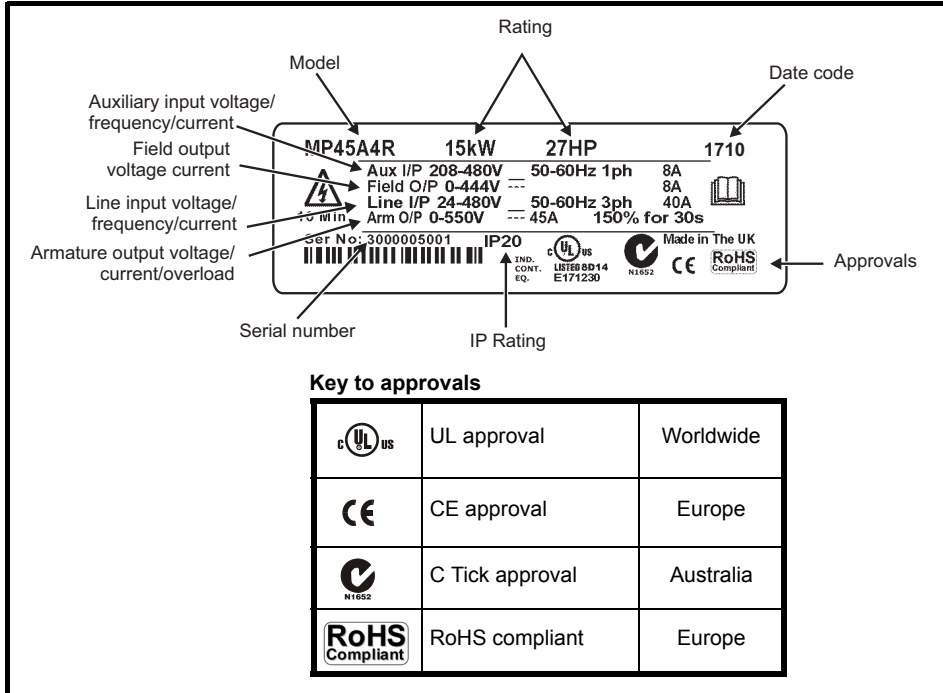
## 2.4 Compatible encoders

Table 2-5 Encoders compatible with Mentor MP

Encoder type	Pr 3.38 (Fb07, 0.77) setting
Quadrature incremental encoders with or without marker pulse	Ab (0)
Frequency and direction incremental encoders with or without marker pulse	Fd (1)
Forward / reverse incremental encoders with or without marker pulse	Fr (2)

## 2.5 Nameplate description

Figure 2-3 Typical drive rating label



### 2.5.1 Output current

The continuous output current ratings given on the rating label are for maximum 40 °C (104 °F) and 1000 m altitude. Derating is required for higher ambient temperatures >40 °C (104 °F) and higher altitude. For derating information, refer to section 12.1.12 *Altitude* on page 155.

### 2.5.2 Input current

The input current is affected by the supply voltage, frequency and load inductance. The input current given on the rating label is the typical input current.

## 2.6 Drive features and options

Figure 2-4 Drive features and options on size 1

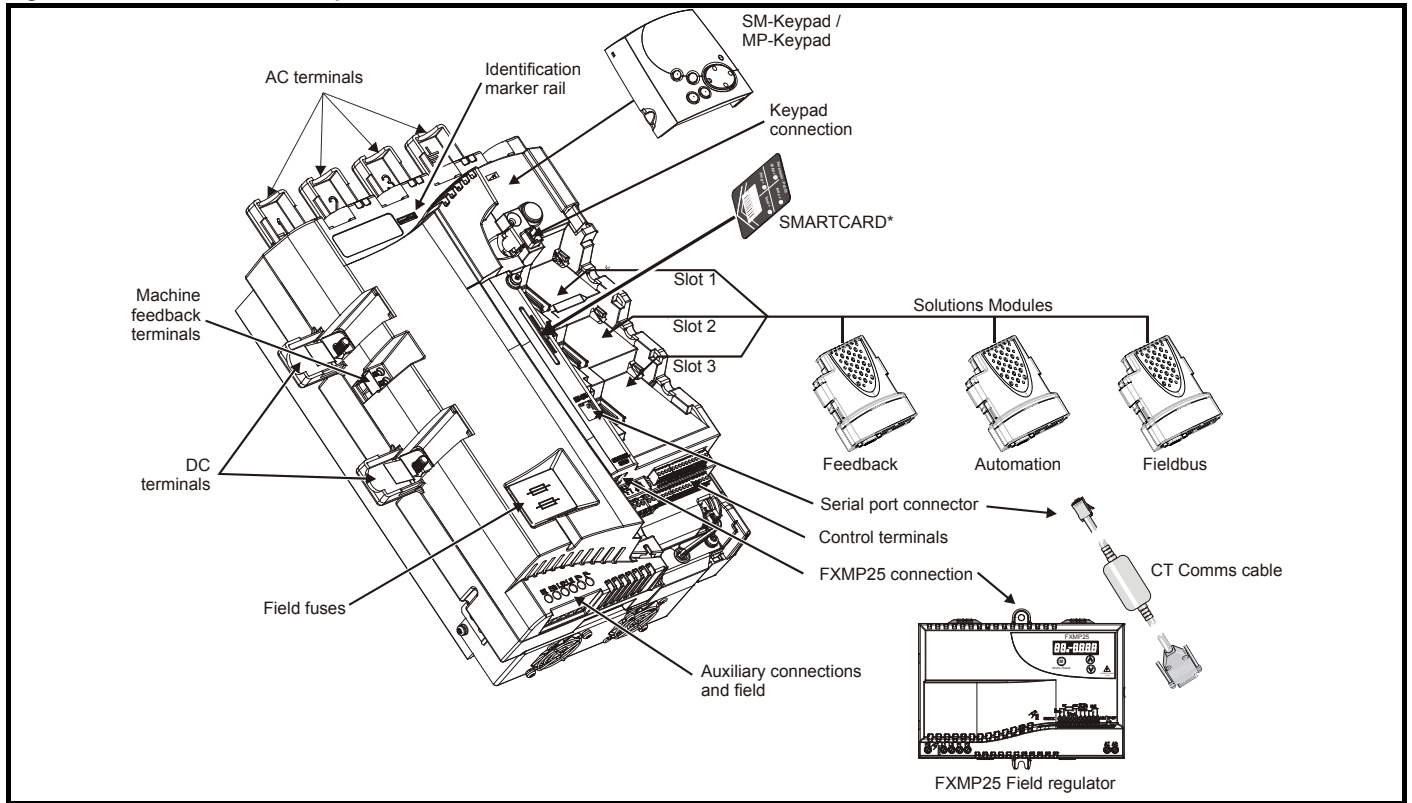
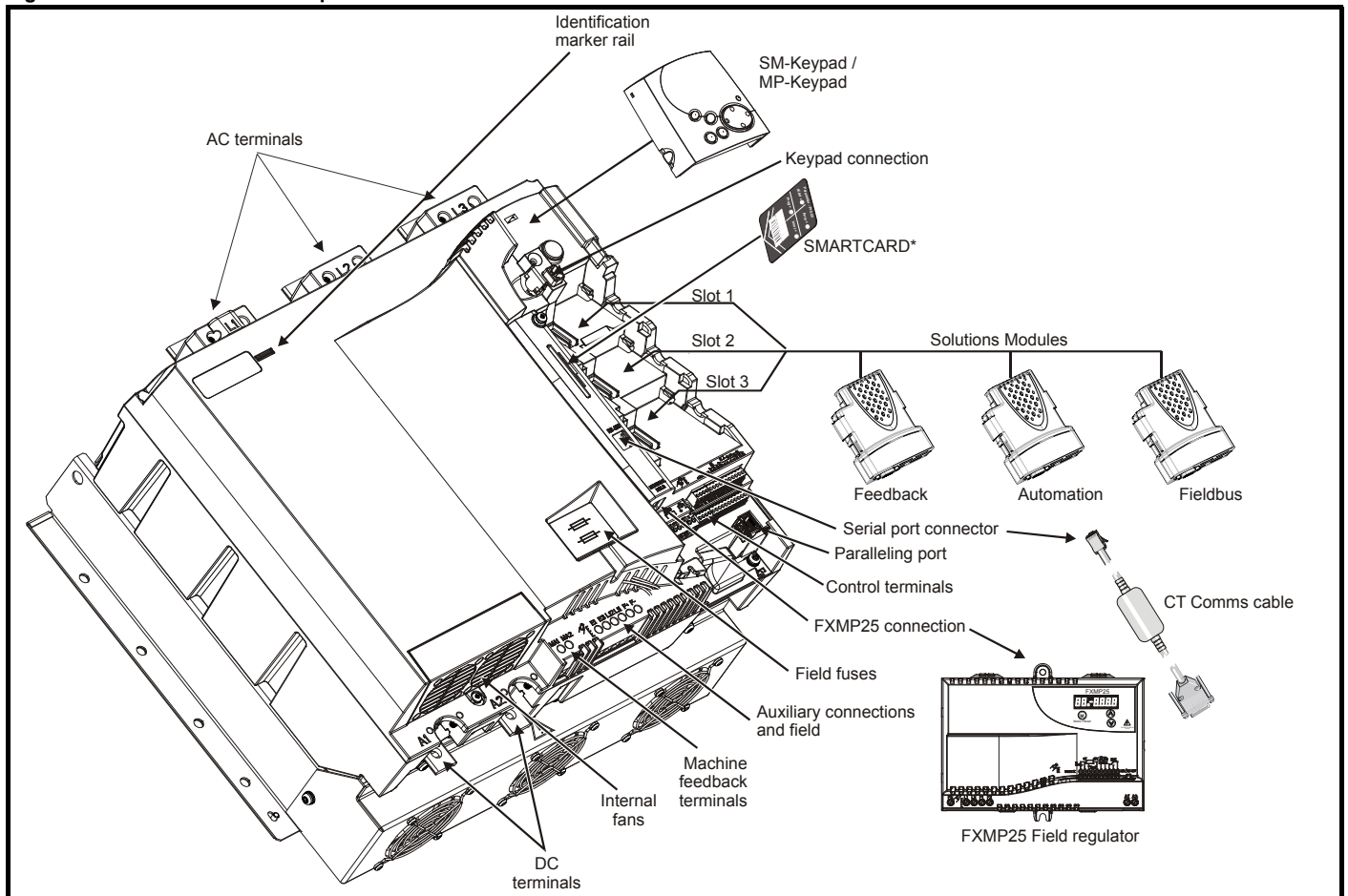


Figure 2-5 Drive features and options for size 2














\* A SMARTCARD is provided as standard. For further information, refer to Chapter 9 *SMARTCARD operation* on page 88.

## 2.6.1 Options available for Mentor MP










All Solutions Modules are color-coded in order to make identification easy. The following table shows the color-code key and gives further details on their function.

Table 2-6 Solutions Module identification

Type	Solutions Module	Color	Name	Further Details
Feedback		Light Green	SM-Universal Encoder Plus	<b>Universal Feedback interface</b> Feedback interface for the following devices: <b>Inputs</b> <ul style="list-style-type: none"> <li>Incremental encoders</li> <li>SinCos encoders</li> <li>SSI encoders</li> <li>EnDat encoders</li> </ul> <b>Outputs</b> <ul style="list-style-type: none"> <li>Quadrature</li> <li>Frequency and direction</li> <li>SSI simulated outputs</li> </ul>
		Brown	SM-Encoder Plus	<b>Incremental encoder interface</b> Feedback interface for incremental encoders without commutation signals. No simulated encoder outputs available
		Dark Brown	SM-Encoder Output Plus	<b>Incremental encoder interface</b> Feedback interface for incremental encoders without commutation signals. Simulated encoder output for quadrature, frequency and direction signals
		N/A	15-way D-type converter*	<b>Drive encoder input converter</b> Provides screw terminal interface for encoder wiring and spade terminal for shield
		N/A	Single ended encoder interface (15 V or 24 V)*	<b>Single ended encoder interface</b> Provides an interface for single ended ABZ encoder signals, such as those from hall effect sensors. 15 V and 24 V versions are available.
Automation (I/O Expansion)		Yellow	SM-I/O Plus	<b>Extended I/O interface</b> Increases the I/O capability by adding the following to the existing I/O in the drive: <ul style="list-style-type: none"> <li>Digital inputs x 3</li> <li>Digital I/O x 3</li> <li>Analog inputs (voltage) x 2</li> <li>Analog output (voltage) x 1</li> <li>Relay x 2</li> </ul>
		Yellow	SM-I/O 32	<b>Extended I/O interface</b> Increase the I/O capability by adding the following to the existing I/O in the drive: <ul style="list-style-type: none"> <li>High speed digital I/O x 32</li> <li>+24 V output</li> </ul>
		Dark Yellow	SM-I/O Lite	<b>Additional I/O</b> 1 x Analog input ( $\pm 10$ V bi-polar or current modes) 1 x Analog output (0 to 10 V or current modes) 3 x Digital input and 1 x Relay
		Dark Red	SM-I/O Timer	<b>Additional I/O with real time clock</b> As per SM-I/O Lite but with the addition of a Real Time Clock for scheduling drive running
		Turquoise	SM-I/O PELV	<b>Isolated I/O to NAMUR NE37 specifications</b> For chemical industry applications 1 x Analog input (current modes) 2 x Analog outputs (current modes) 4 x Digital input / outputs, 1 x Digital input, 2 x Relay outputs
		Olive	SM-I/O 120V	<b>Additional I/O conforming to IEC 61131-2 120 Vac</b> 6 digital inputs and 2 relay outputs rated for 120 Vac operation
		Cobalt Blue	SM-I/O 24V Protected	<b>Additional I/O with overvoltage protection up to 48 V</b> 2 x Analog outputs (current modes) 4 x Digital input / outputs, 3 x Digital inputs, 2 x Relay outputs





**Table 2-6 Solutions Module identification**

Type	Solutions Module	Color	Name	Further Details
Automation (Applications)		Moss Green	SM-Applications Plus	<b>Applications Processor (with CTNet)</b> 2 <sup>nd</sup> processor for running pre-defined and /or customer created application software with CTNet support. Enhanced performance over SM-Applications
		White	SM-Applications Lite V2	<b>Applications Processor</b> 2 <sup>nd</sup> processor for running pre-defined and /or customer created application software. Enhanced performance over SM-Applications Lite
		Golden brown	SM-Register	<b>Applications Processor</b> 2 <sup>nd</sup> processor for running position capture functionality with CTNet support.
Fieldbus		Purple	SM-PROFIBUS DP-V1	<b>Profibus option</b> PROFIBUS DP adapter for communications with the drive
		Medium Grey	SM-DeviceNet	<b>DeviceNet option</b> Devicenet adapter for communications with the drive
		Dark Grey	SM-INTERBUS	<b>Interbus option</b> Interbus adapter for communications with the drive
		Light Grey	SM-CANopen	<b>CANopen option</b> CANopen adapter for communications with the drive
		Beige	SM-Ethernet	<b>Ethernet option</b> 10 base-T / 100 base-T; Supports web pages, SMTP mail and multiple protocols: DHCP IP addressing; Standard RJ45 connection
		Brown Red	SM-EtherCAT	<b>EtherCAT option</b> EtherCAT adapter for communications with the drive


**NOTE**

\* UT01 (15- way D Type Converter) and UT02 (Single ended encoder interface) cannot be used directly with the Mentor MP drive.

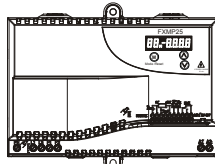
**Table 2-7 Keypad identification**

Keypad	Name	Further Details
	SM-Keypad	<b>LED keypad option</b> Keypad with a LED display
	MP-Keypad	<b>LCD keypad option</b> Keypad with an alpha-numeric LCD display with Help function

**Table 2-8 Serial comms lead**

Serial comms lead	Name	Further Details
	CT Comms cable	CT EIA (RS) -232 (4500-0087) CT USB (4500-0096)

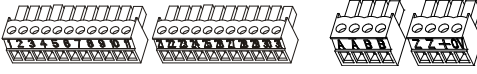

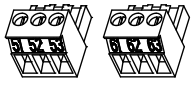

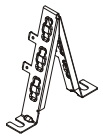
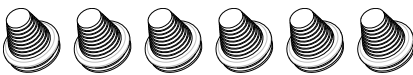

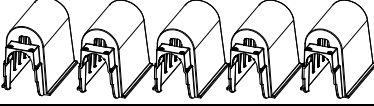


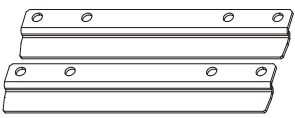
**Table 2-9 External field control**

External field controller	Name	Further Details
	FXMP25	For external control of field windings up to 25 A, with field reversal capability. For further information, please see the <i>FXMP25 User Guide</i> .

## 2.7 Items supplied with the drive

The drive is supplied with a printed manual, a SMARTCARD, a safety information booklet, an accessory kit box including the items shown in Table 2-10.

Table 2-10 Parts supplied with the drive

Description	Size 1	Size 2A / 2B	Size 2C / 2D
Control connectors			
Tacho connector			
Relay connectors			
UL warning label	<div style="border: 1px solid black; padding: 5px; text-align: center;"> <b>CAUTION</b>            Risk of Electric Shock            Power down until 10minutes            before removing cover.         </div>		
UL warning label for heatsink temperature			
Grounding bracket			
Terminal cover grommets			
Terminal shrouds			
Terminal shroud base covers			
M4 Screws			
Mounting feet bracket			

## 3 Mechanical Installation

### 3.1 Safety



Follow the instructions

The mechanical and electrical installation instructions must be adhered to. Any questions or doubt should be referred to the supplier of the equipment. It is the responsibility of the owner or user to ensure that the installation of the drive and any external option unit, and the way in which they are operated and maintained, comply with the requirements of the Health and Safety at Work Act in the United Kingdom or applicable legislation and regulations and codes of practice in the country in which the equipment is used.



Competence of the installer

The drive must be installed by professional assemblers who are familiar with the requirements for safety and EMC. The assembler is responsible for ensuring that the end product or system complies with all the relevant laws in the country where it is to be used.



If the drive has been used at high load levels for a period of time, the heatsink can reach temperatures in excess of 70 °C (158 °F). Human contact with the heatsink should be prevented.



Enclosure

The drive is intended to be mounted in an enclosure which prevents access except by trained and authorized personnel, and which prevents the ingress of contamination. It is designed for use in an environment classified as pollution degree 2 in accordance with IEC 60664-1. This means that only dry, non-conducting contamination is acceptable.



The drive enclosure is not classified as a fire enclosure. A separate fire enclosure must be provided. For further information, refer to section 3.2.5 *Electromagnetic compatibility* on page 15.



Many of the drives in this product range weigh in excess of 15 kg (33 lb). Use appropriate safeguards when lifting these models. See section 3.4 *Mounting method* on page 19.



IP rating

It is the installer's responsibility to ensure that any enclosure which allows access to drives from model sizes 2A to 2D while the product is energized, provides protection against contact and ingress to the requirements of IP20. Refer to section 12-8 *IP rating* on page 155.

### 3.2 Planning the installation

The following considerations must be made when planning the installation:

#### 3.2.1 Access

Access must be restricted to personnel only. Safety regulations which apply at the place of use must be complied with.

#### 3.2.2 Environmental protection

The drive must be protected from:

- moisture, including dripping water or spraying water and condensation. An anti-condensation heater may be required, which must be switched off when the drive is running
- contamination with electrically conductive material
- contamination with any form of dust which may restrict the fan, or impair airflow over various components
- temperature beyond the specified operating and storage ranges
- corrosive gasses

#### 3.2.3 Cooling

The heat produced by the drive must be removed without its specified operating temperature being exceeded. Note that a sealed enclosure gives much reduced cooling compared with a ventilated one, and may need to be larger and/or use internal air circulating fans.

For further information, refer to section 3.6.2 *Enclosure sizing* on page 29.

#### 3.2.4 Electrical safety

The installation must be safe under normal and fault conditions. Electrical installation instructions are given in Chapter 4 *Electrical installation* on page 35.

#### 3.2.5 Electromagnetic compatibility

If it is necessary to meet strict emission limits, or if it is known that electromagnetically sensitive equipment is located nearby, then full precautions must be observed. The use of an external EMC filter may be required at the drive inputs, which must be located very close to the drives.

Space must be made available for the filters and allowance made for carefully segregated wiring. Both levels of precautions are covered in Table 12-44 *Immunity compliance* on page 179.

#### 3.2.6 Hazardous areas

The drive must not be located in a classified hazardous area unless it is installed in an approved enclosure and the installation is certified.

#### 3.2.7 Fire protection

The drive enclosure is not classified as a fire enclosure. A separate fire enclosure must be provided.

For installation in the USA, a NEMA 12 enclosure is suitable.

For installation outside the USA, the following (based on IEC 62109-1, standard for PV inverters) is recommended.

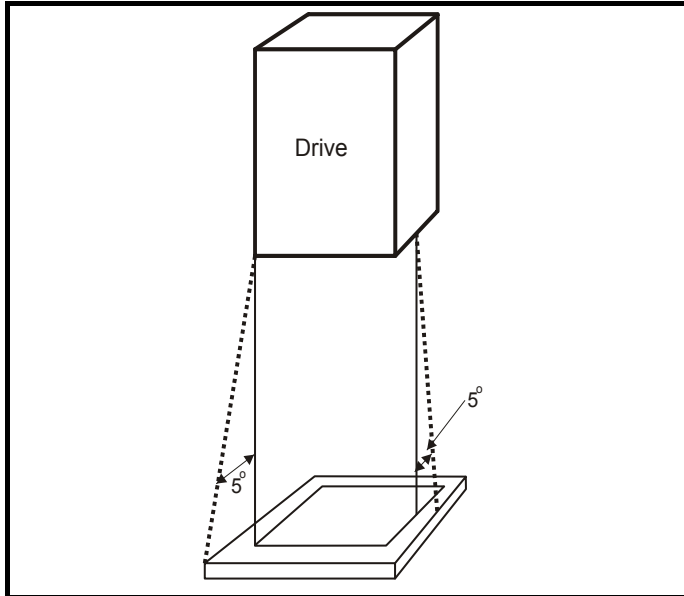
Enclosure can be metal and/or polymeric, polymer must meet requirements which can be summarized for larger enclosures as using materials meeting at least UL 94 class 5VB at the point of minimum thickness.

Air filter assemblies to be at least class V-2.

The location and size of the bottom shall cover the area shown in Figure 3-1 overleaf.

Any part of the side which is within the area traced out by the 5° angle is also considered to be part of the bottom of the fire enclosure.

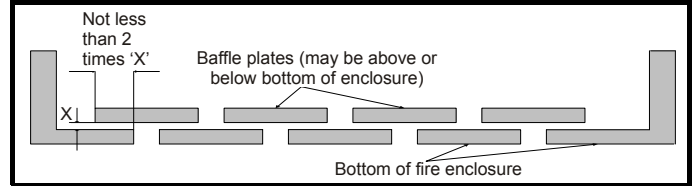
**Figure 3-1 Fire enclosure bottom layout**



The bottom, including the part of the side considered to be part of the bottom, must be designed to prevent escape of burning material - either by having no openings or by having a baffle construction.

This means that openings for cables etc. must be sealed with materials meeting the 5VB requirement, or else have a baffle above. See Figure 3-2 for acceptable baffle construction. This does not apply for mounting in an enclosed electrical operating area (restricted access) with concrete floor.

**Figure 3-2 Fire enclosure baffle construction**



### 3.3 Terminal cover removal



**Isolation device**

The AC supply must be disconnected from the drive using an approved isolation device before any cover is removed from the drive or before any servicing work is performed.



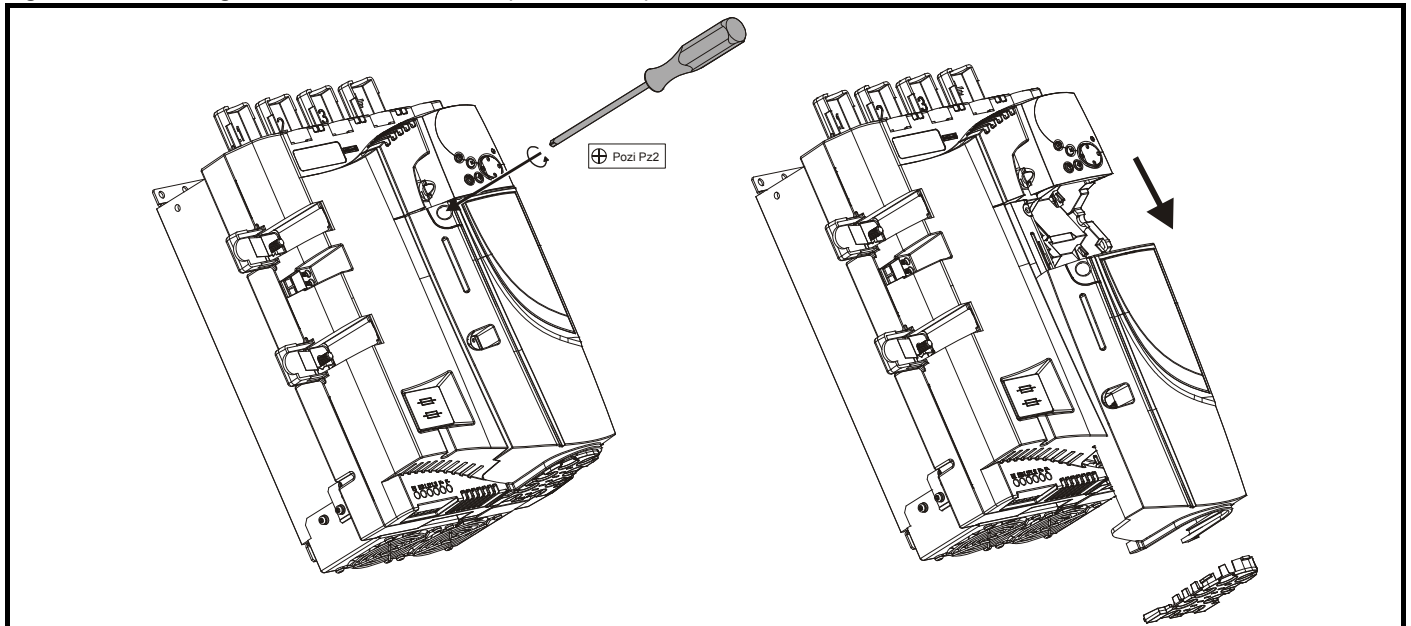
**Stored charge**

The drive contains capacitors that remain charged to a potentially lethal voltage after the AC supply has been disconnected. If the drive has been energized, the AC supply must be isolated at least ten minutes before work may continue.

#### 3.3.1 Removing the terminal covers

The drive is installed with one control terminal cover.

**Figure 3-3 Removing the control terminal cover (size 1 shown)**

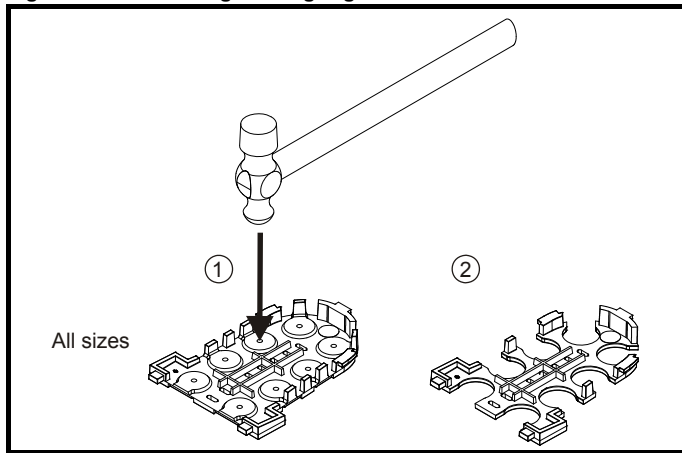


To remove the terminal cover, undo the screw and slide the terminal cover downwards.

When replacing the terminal covers the screw should be tightened with a maximum torque of 1 N m (0.7 lb ft).


### 3.3.2 Removing the finger-guard and break-outs

Figure 3-4 Removing the finger-guard break-outs



Place finger-guard on a flat solid surface and hit relevant break-outs with hammer as shown (1). Continue until all required break-outs are removed (2). Remove any flash / sharp edges once the break-outs are removed.

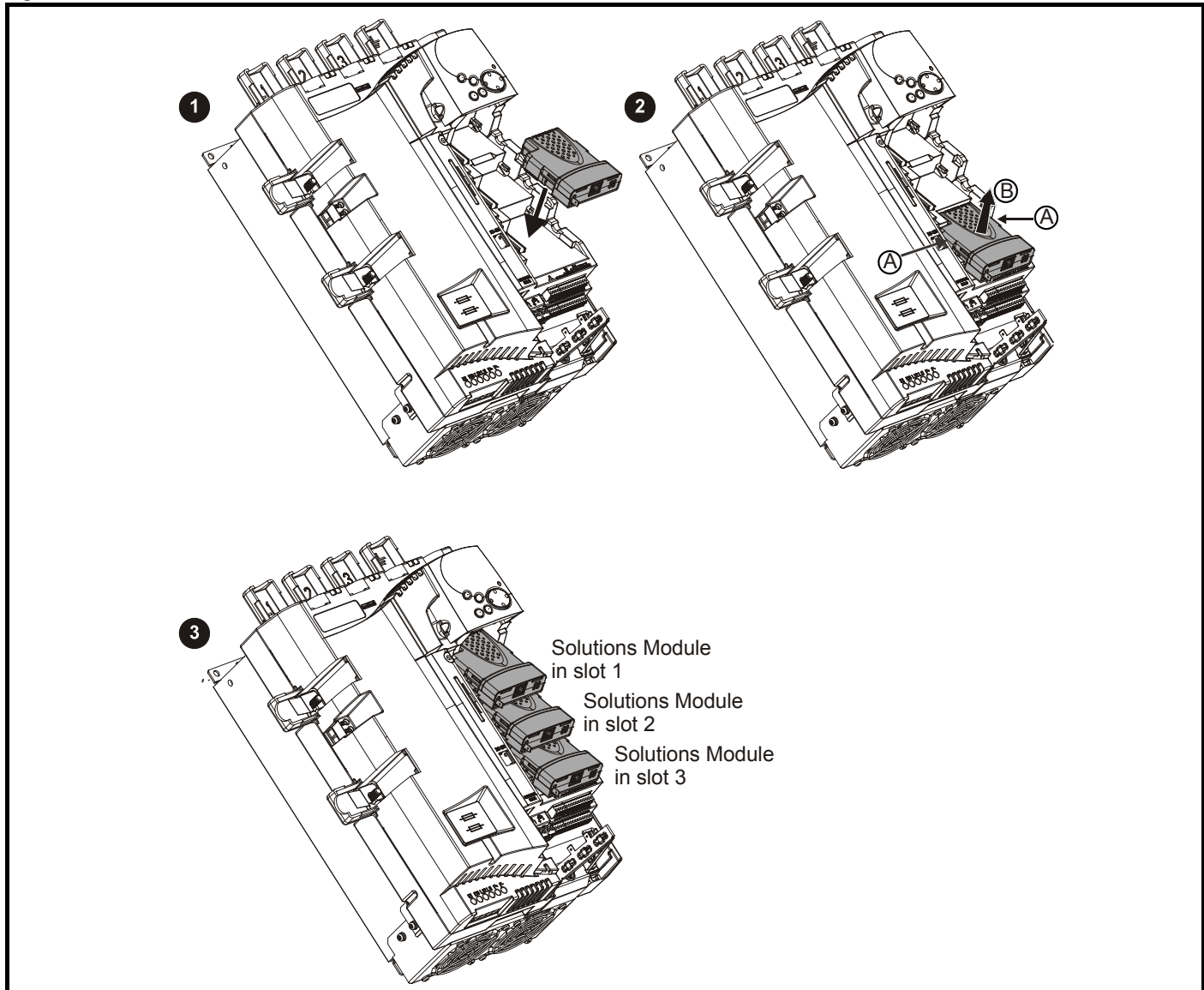
### 3.3.3 Installation and removal of a Solutions Module



Please power down the drive before removing / installing the Solutions Module. Failure to do so may cause damage to product

**CAUTION**

Figure 3-5 Installation and removal of the Solutions Module



- To install the Solutions Module, press down in the direction shown above until it clicks into place.
- To remove the Solutions Module, press inwards at the points shown (A) and pull in the direction shown (B).

- The drive has the facility for all three Solutions Module slots to be used at the same time, as illustrated.

**NOTE**

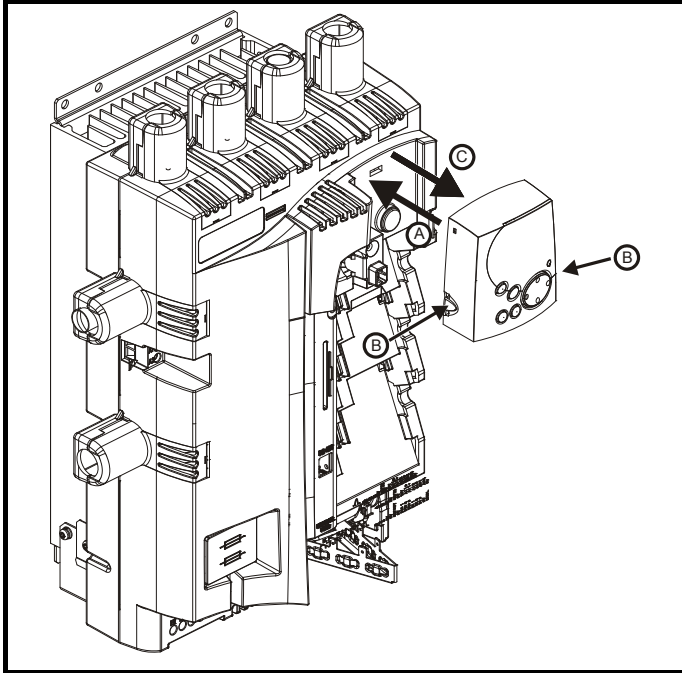
It is recommended that the Solutions Module slots are used in the following order: slot 3, slot 2 and slot 1.



Be aware of possible live terminals when installing the keypad.

**WARNING**

**Figure 3-6 Removal and installation of a keypad**



To fit, align the MP-Keypad and press gently in the direction shown until it clicks into position (A).

To remove, while pressing the tabs inwards (B), gently lift the MP-Keypad in the direction indicated (C).

**NOTE**

The keypad can be installed / removed while the drive is powered up and running a motor, providing that the drive is not operating in keypad mode.

### 3.4 Mounting method

The Mentor MP can only be surface mounted.

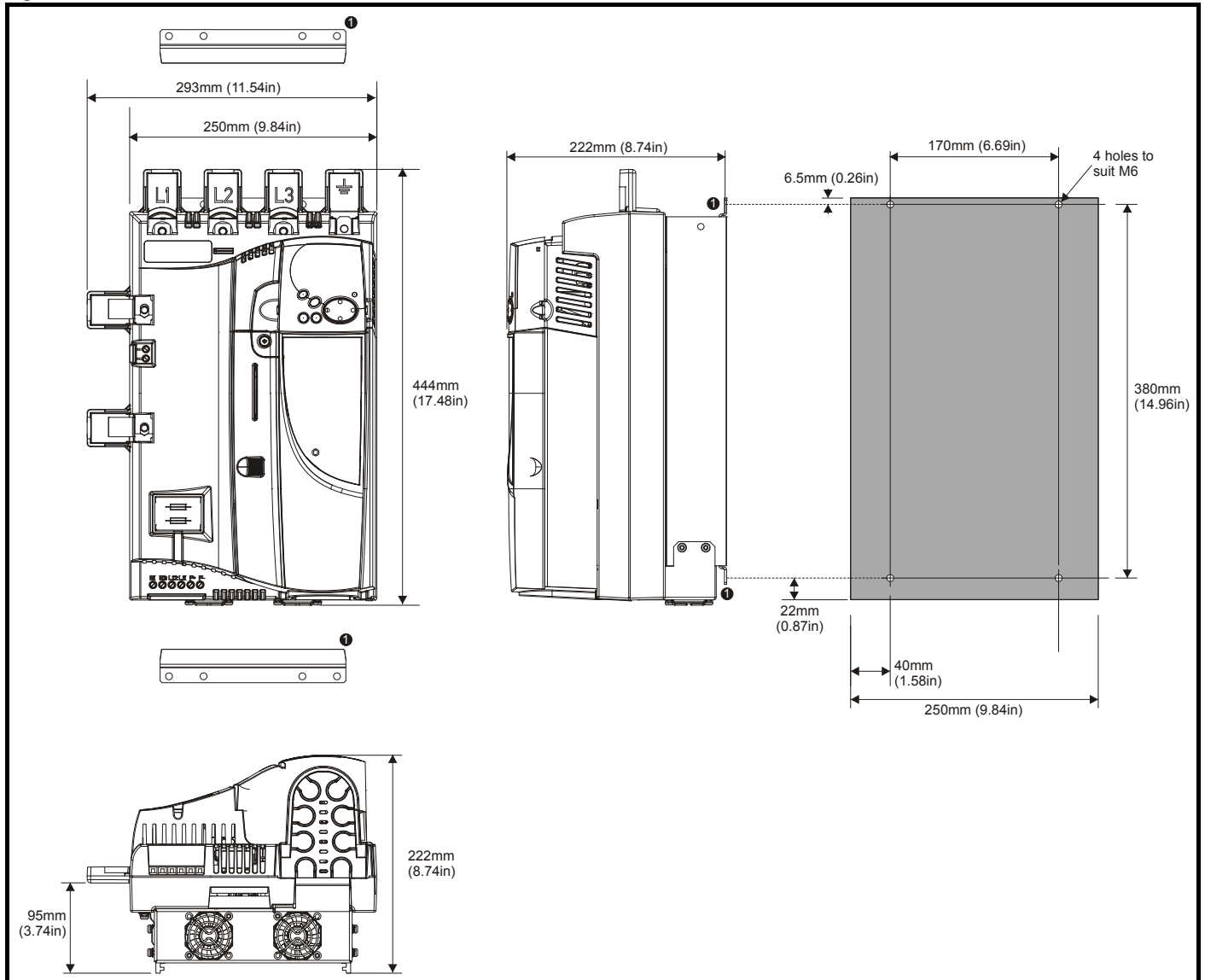


If the drive has been used at high load levels for a period of time, the heatsink can reach temperatures in excess of 70 °C (158 °F). Human contact with the heatsink should be prevented.



Many of the drives in this product range weigh in excess of 15 kg (33lb). Use appropriate safeguards when lifting these models.

Figure 3-7 Overall size 1A dimensions



1. The two outer holes must be used for mounting the Mentor MP.

**NOTE**

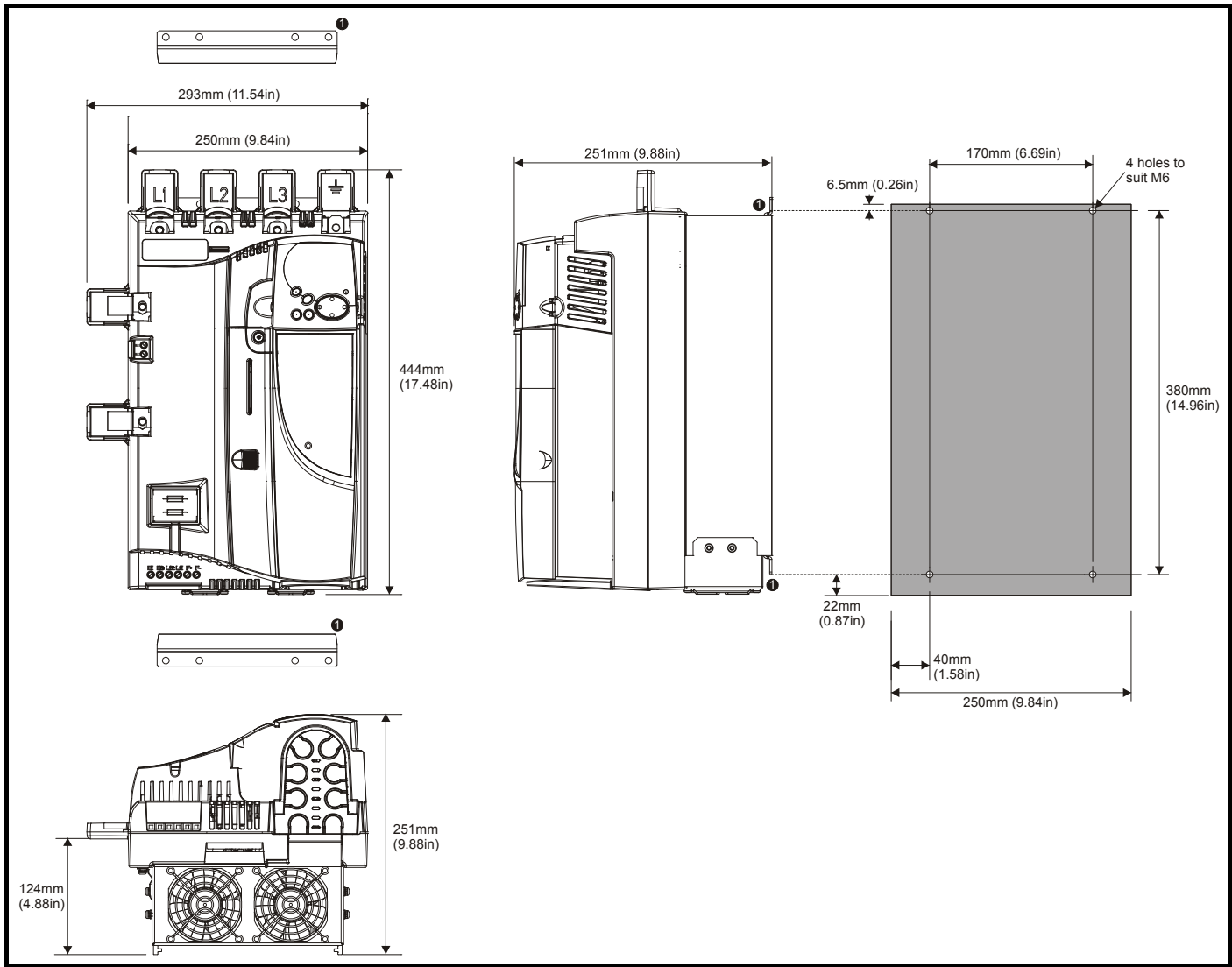
With the SMARTCARD installed to the drive, the depth measurement increases by 7.6 mm (0.30 in).

**NOTE**

Fans are only installed to the MP75A4(R) and MP75A5(R).



**Figure 3-8 Overall size 1B dimensions**



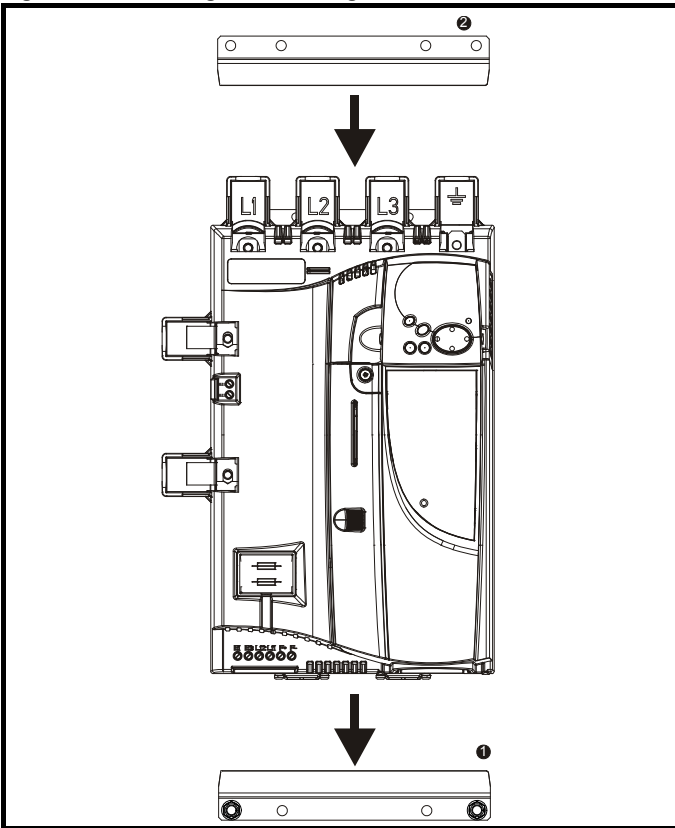
1. The two outer holes must be used for mounting the Mentor MP.

**NOTE**

With the SMARTCARD installed to the drive, the depth measurement increases by 7.6 mm (0.30 in).



**Figure 3-9 Installing the mounting feet bracket on size 1 drives**



The bottom mounting bracket (1) should be installed to the back plate first with the screws fully tightened.

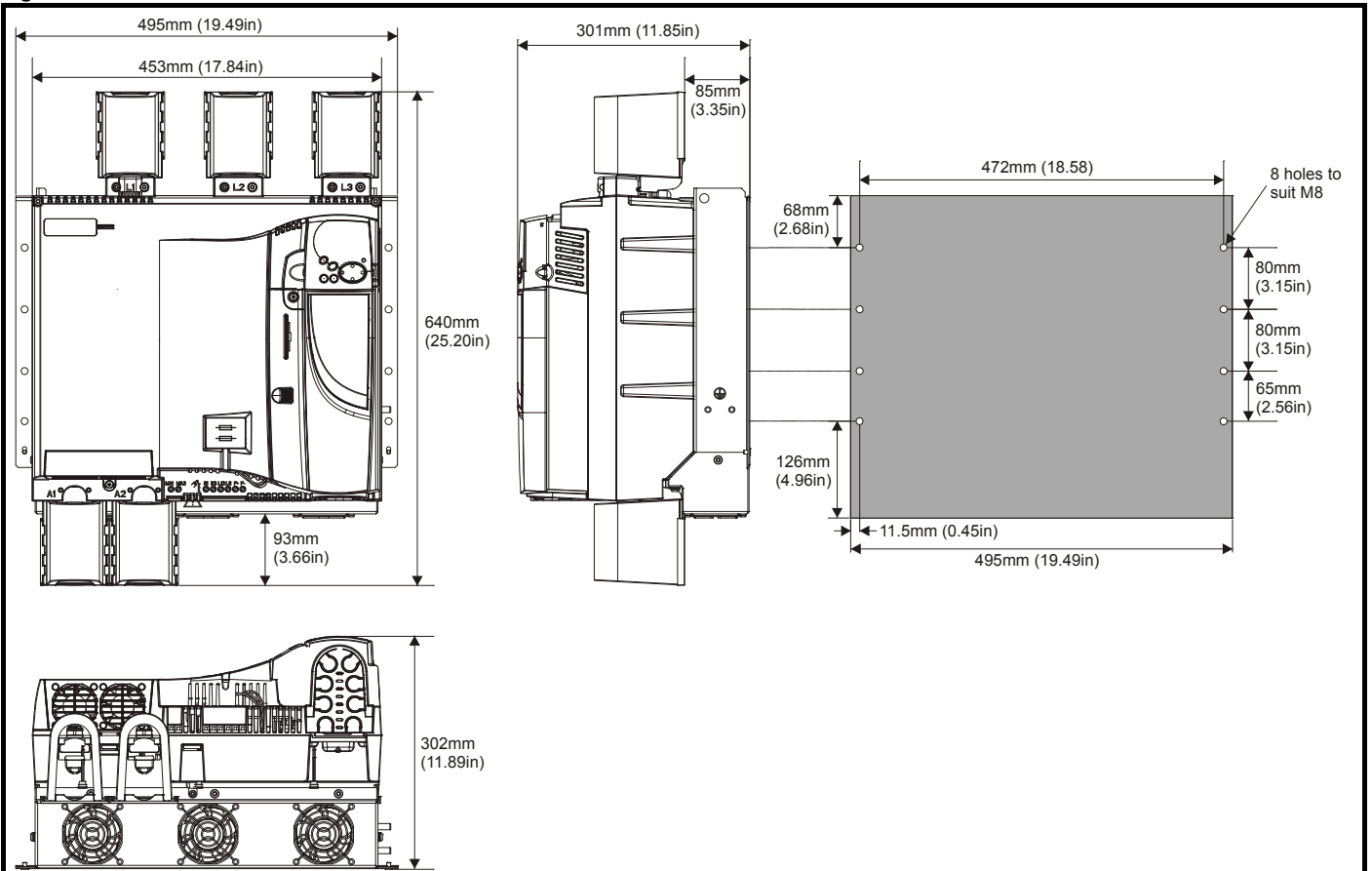
The drive should then be lowered onto the bracket and slotted in.

The top mounting bracket (2) should then be slotted into the drive and the top holes marked for mounting (380 mm [14.96 in] from the centre of the holes on the bottom mounting bracket).

Once the holes have been drilled, fix the top mounting bracket accordingly and tighten the screws.

It is not necessary to tighten the bottom mounting brackets with the drive in place. The brackets are designed to clamp the drive heatsink against the back plate.

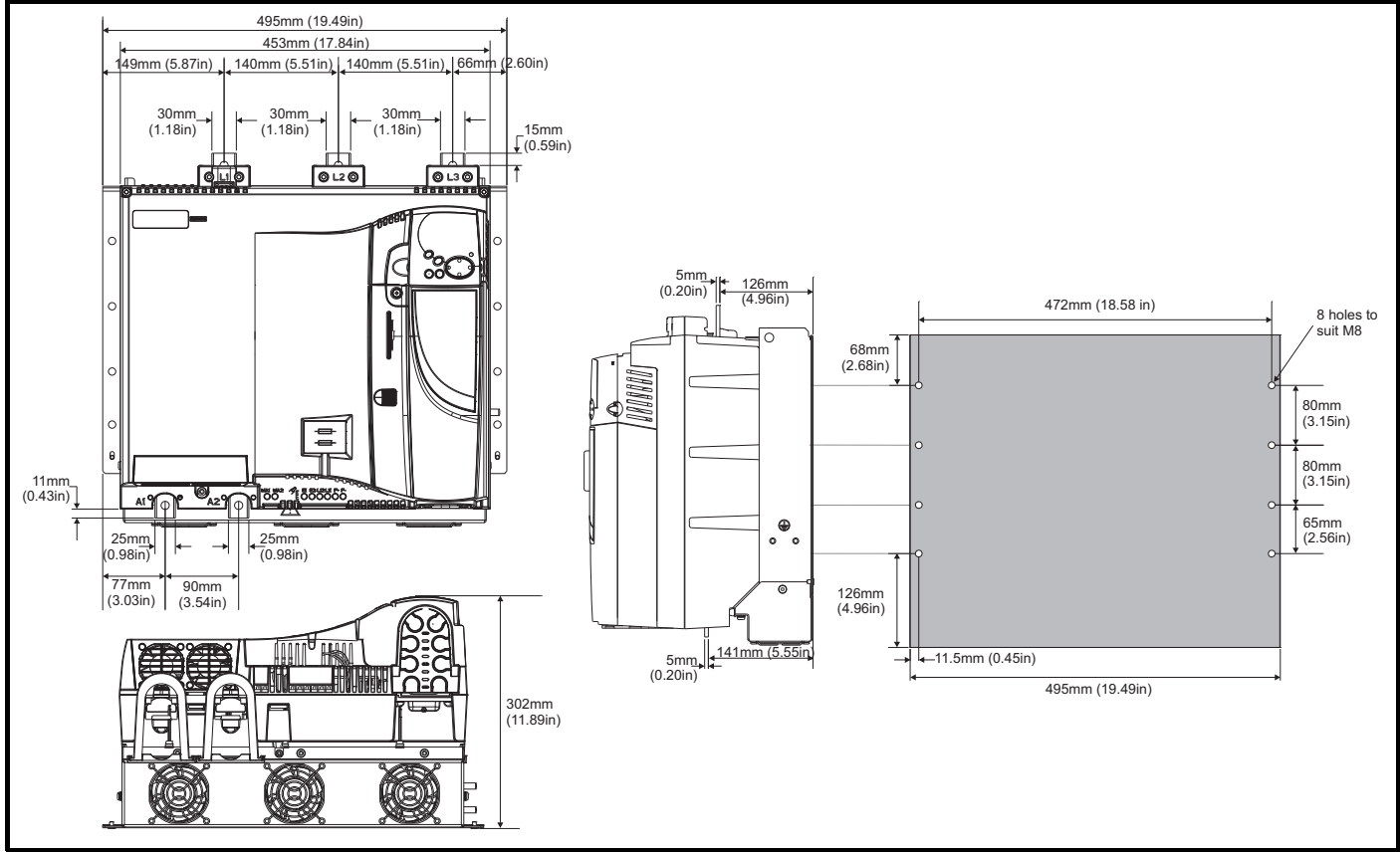
**Figure 3-10 Overall size 2A / 2B dimensions with terminal shrouds attached**



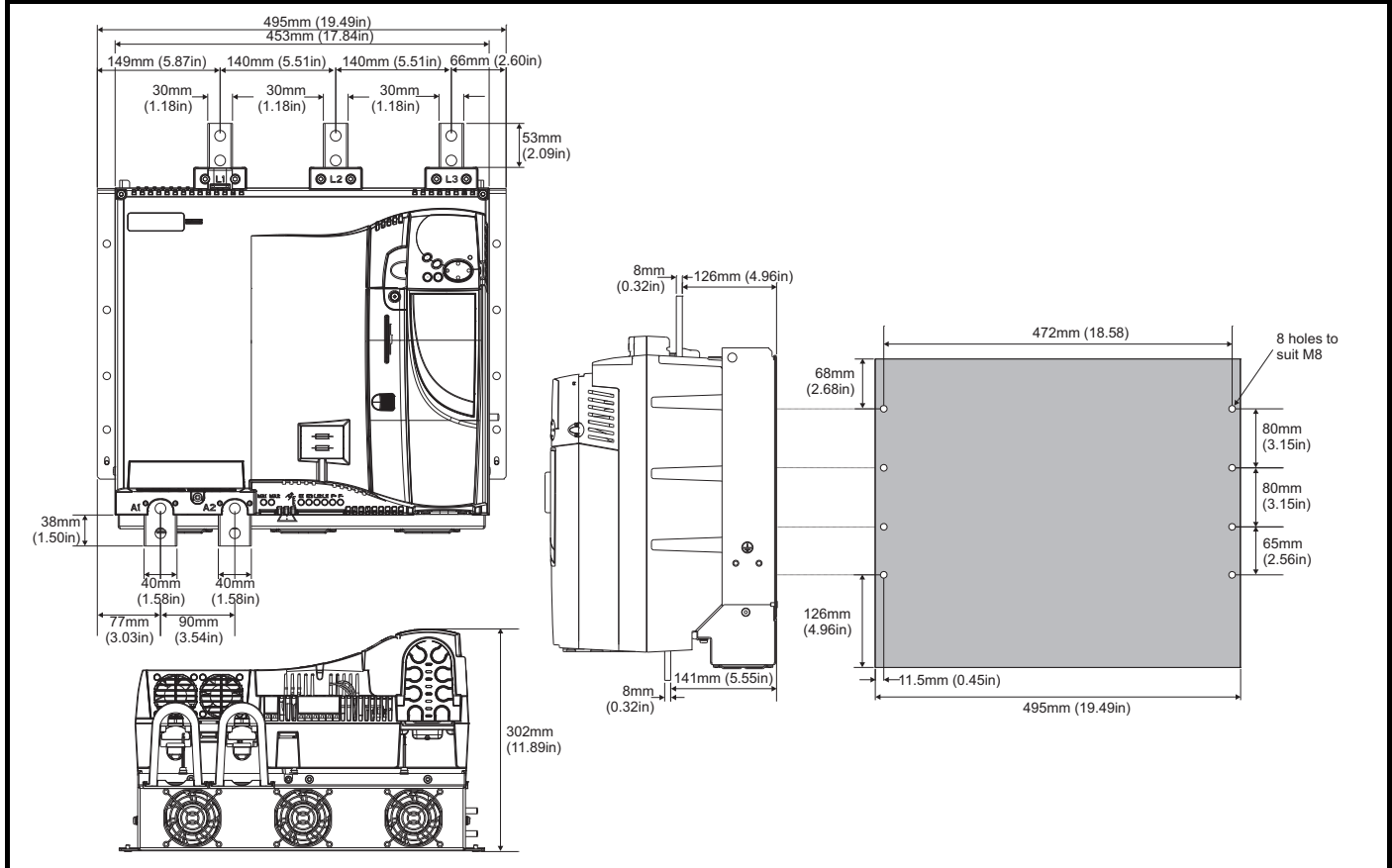
**NOTE**

With the SMARTCARD installed to the drive, the depth measurement increases by 7.6 mm (0.30 in).

**Figure 3-11 Overall size 2A dimensions without terminal shrouds attached**



**Figure 3-12 Overall size 2B dimensions without terminal shrouds attached**



**NOTE**

With the SMARTCARD installed to the drive, the depth measurement increases by 7.6 mm (0.30 in).

Figure 3-13 Size 2C front view and mounting dimensions

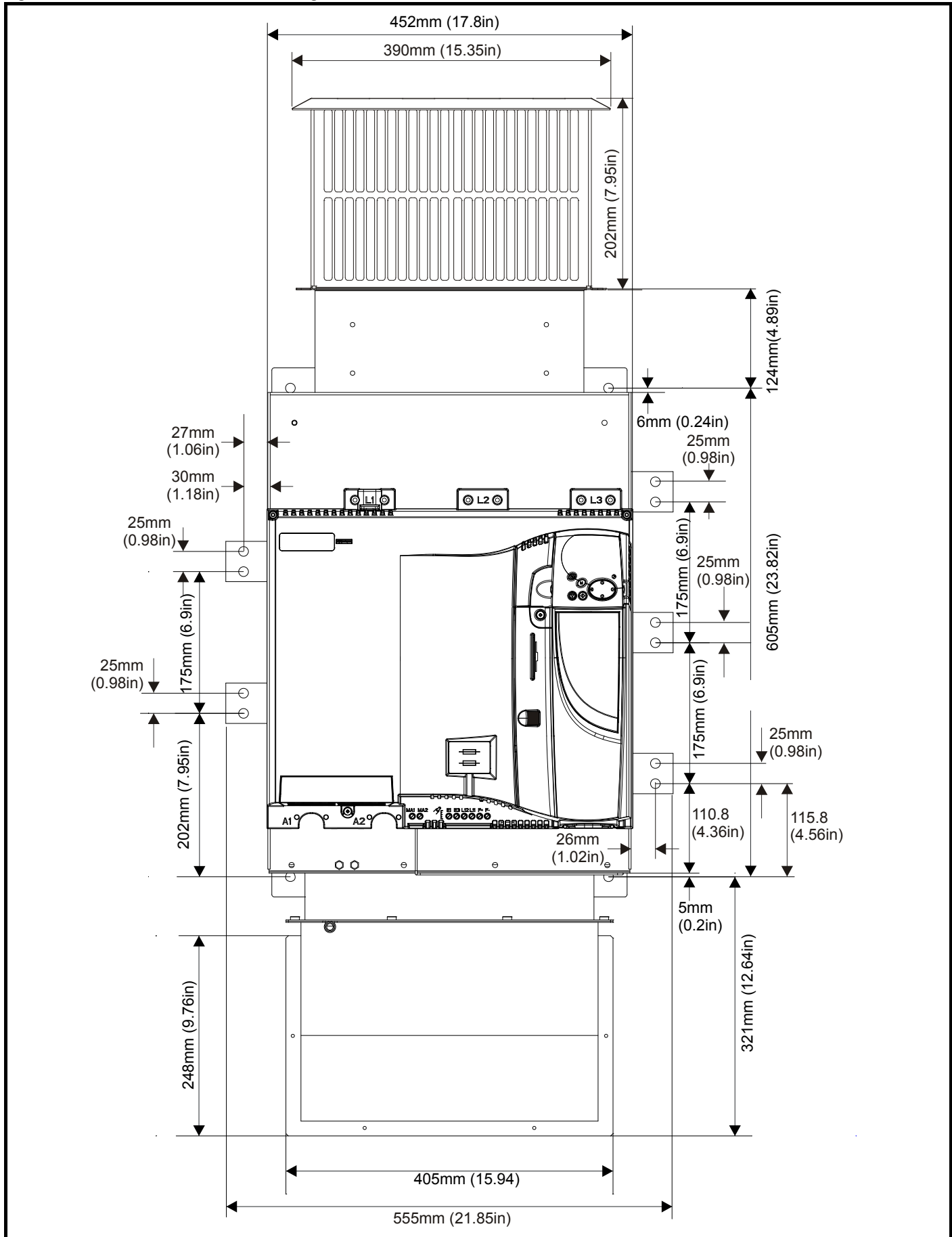
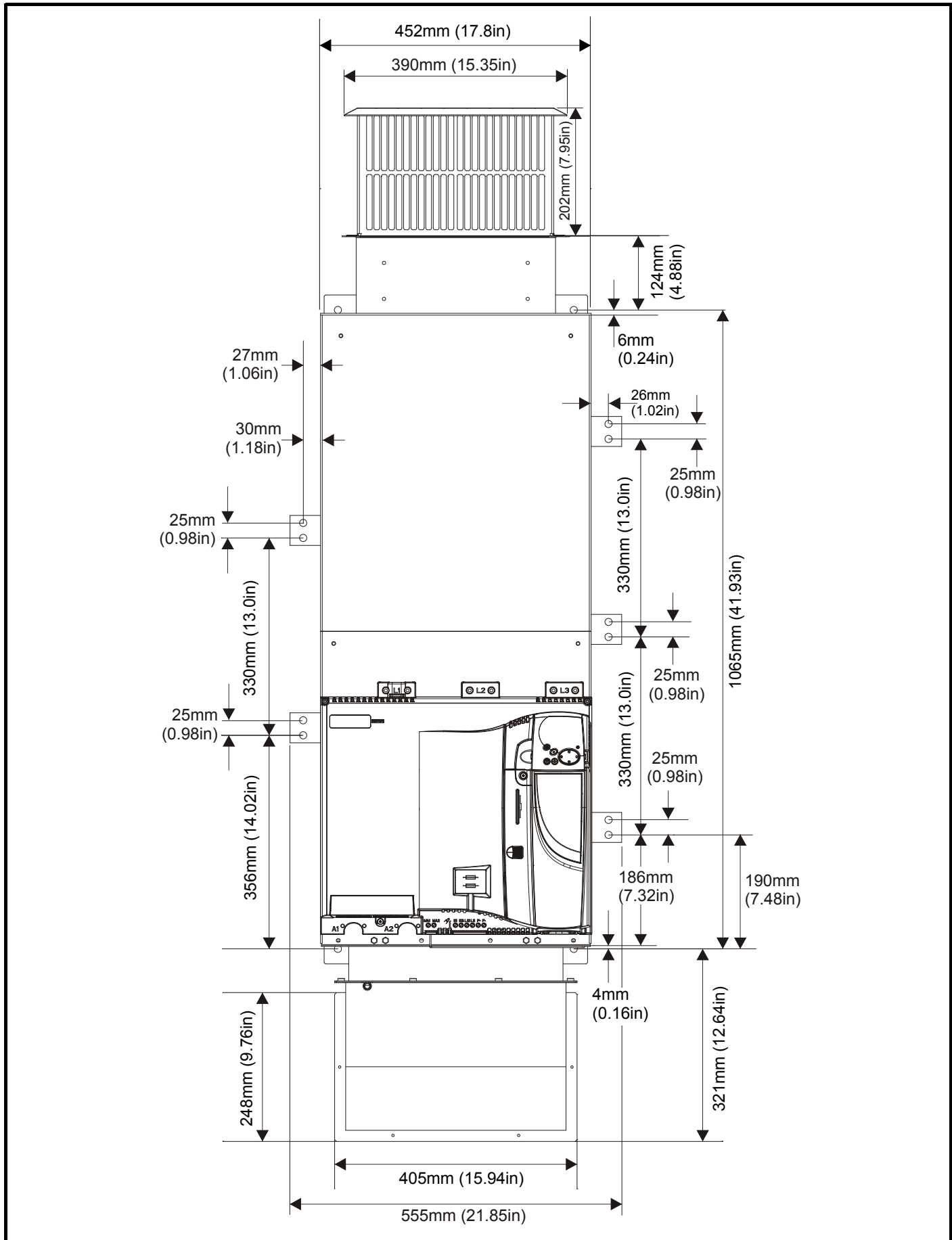
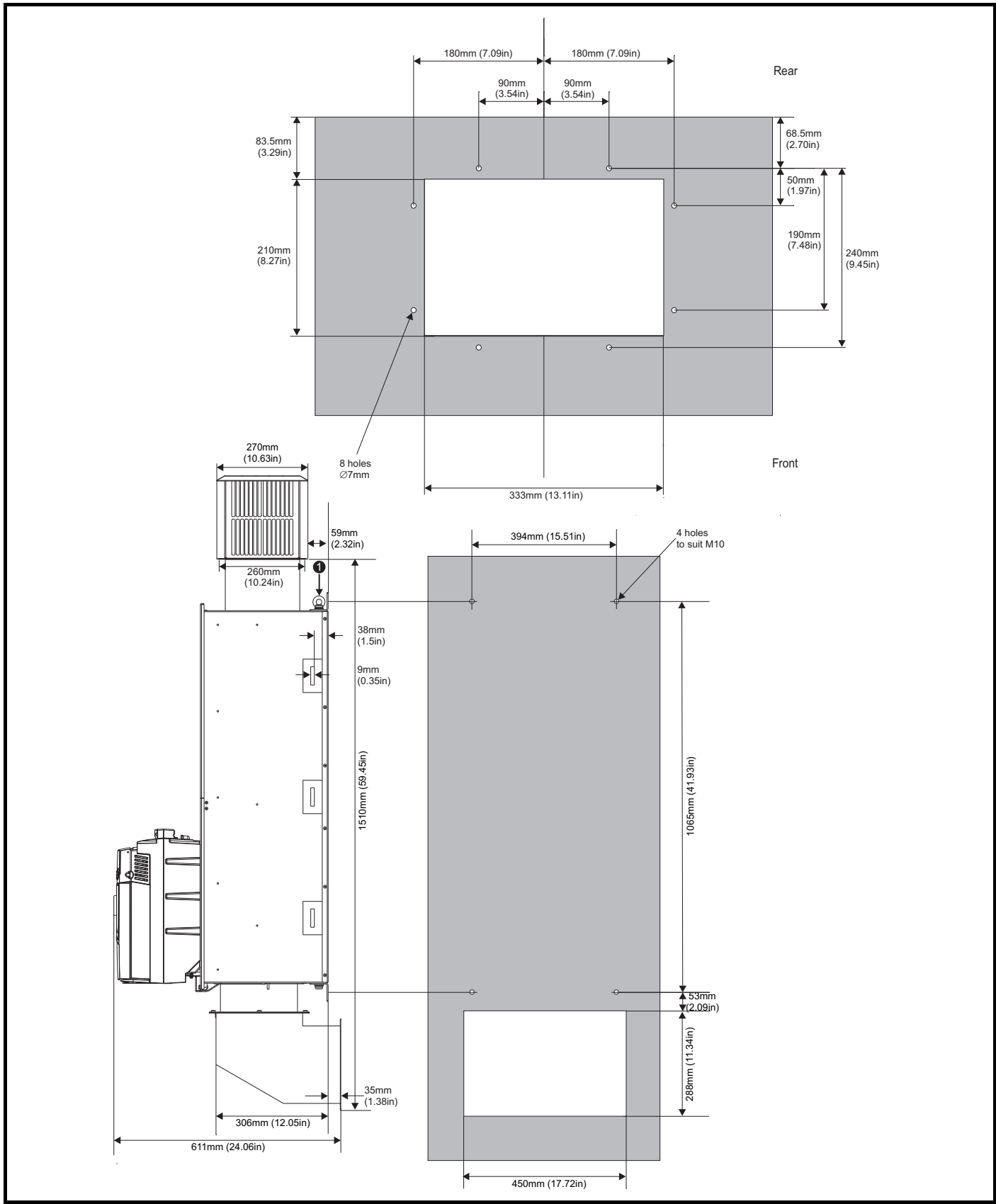




Figure 3-15 Size 2D front view and mounting dimensions



**Figure 3-16 Size 2D back-plate and mounting detail**



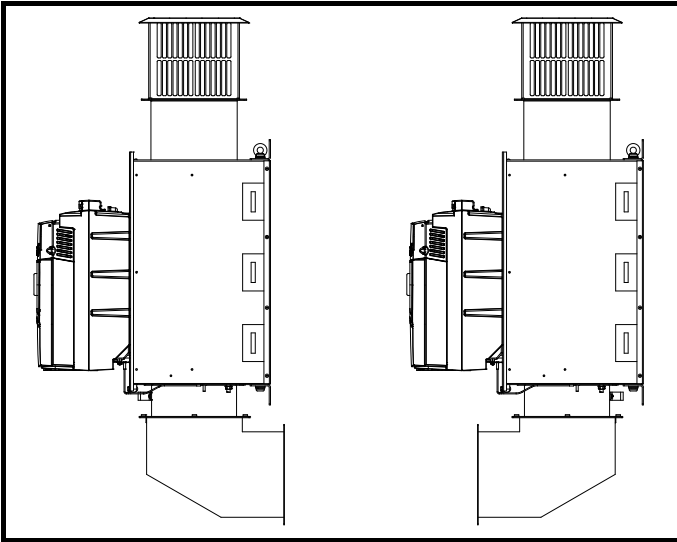
**NOTE**

1. M10 eye-bolts can be inserted in the location shown for lifting the drive. These are not supplied with the drive.

**NOTE**

With the SMARTCARD installed to the drive, the depth measurement increases by 7.6 mm (0.30 in).

**Figure 3-17 Mounting methods of size 2C / 2D air duct**



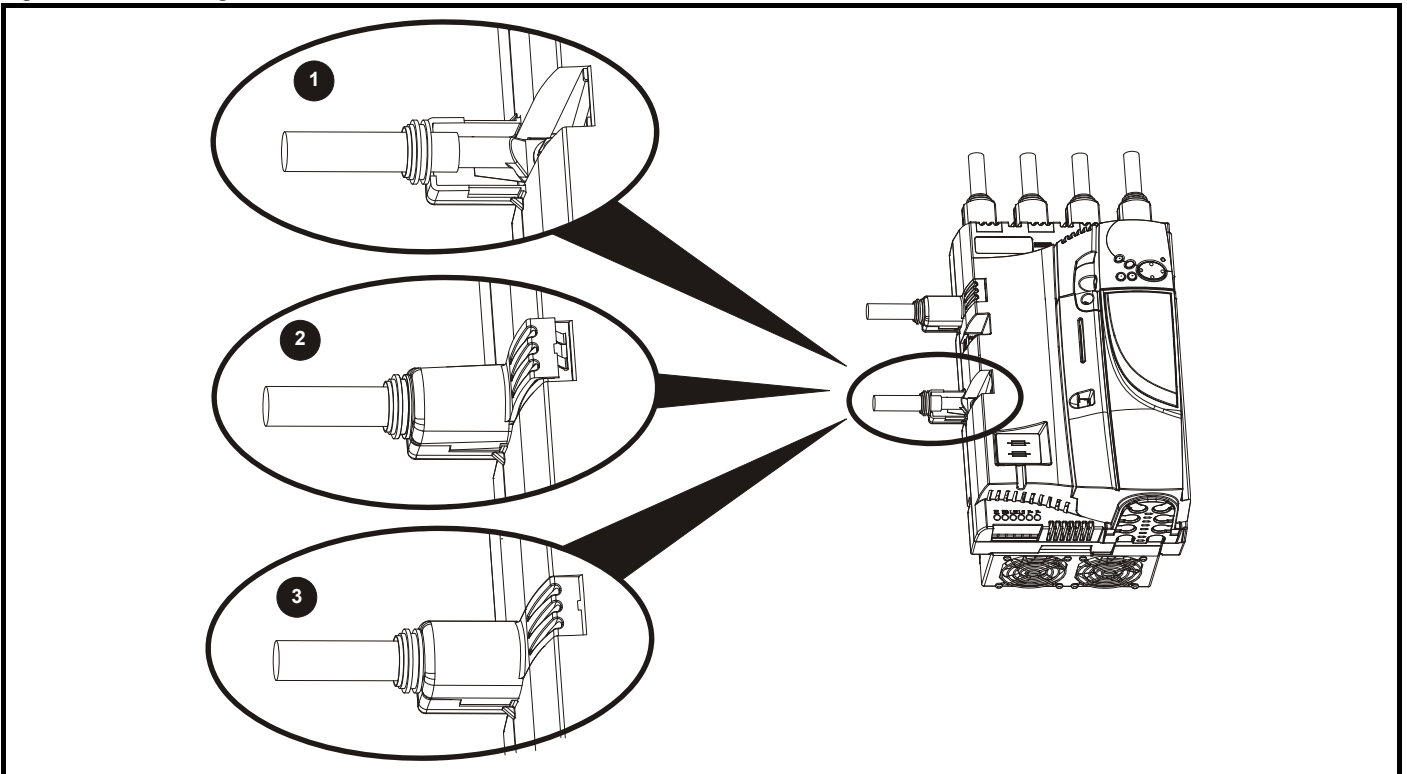
The Mentor MP size 2C and 2D air duct can be turned 180° to suit the customers infrastructure.

**NOTE**

There is no seal provided with this product for sealing off the gap around the air duct when mounted.

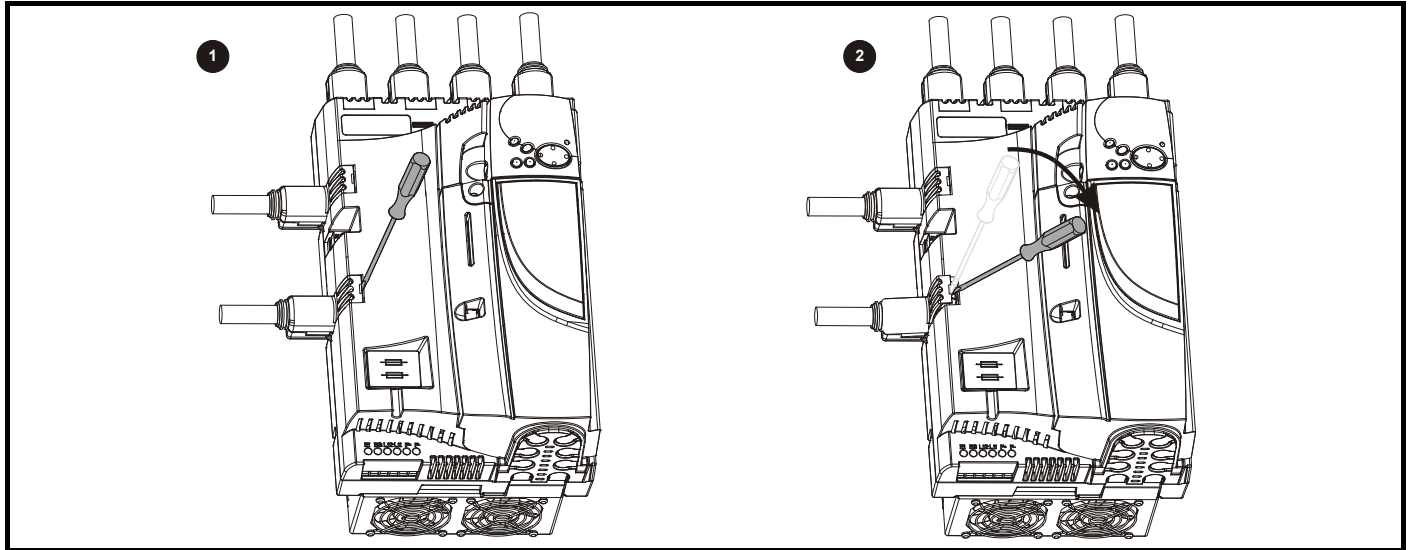
### 3.5 Installing and removing the terminal shrouds

**Figure 3-18 Installing the terminal shrouds on size 1 drives**



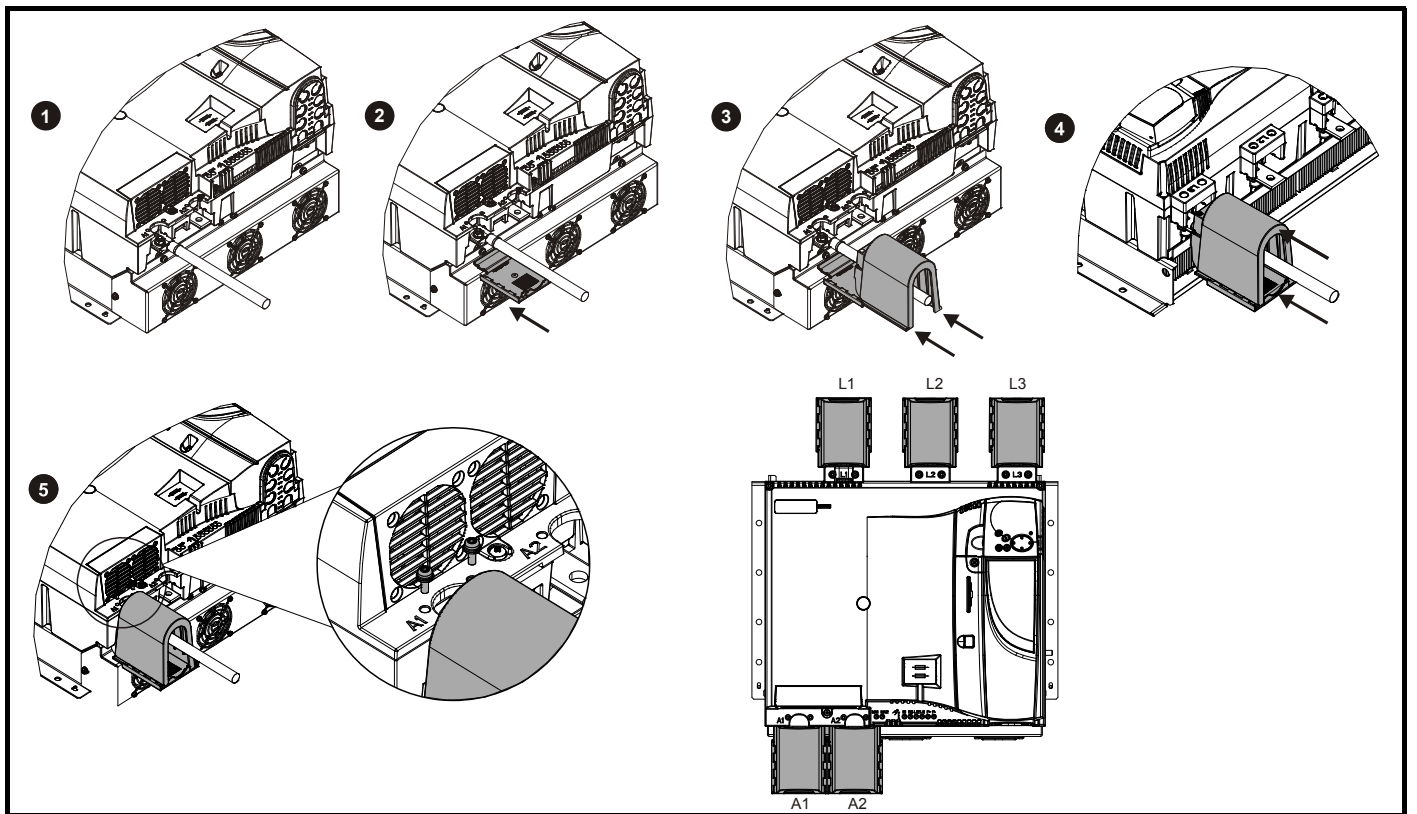
1. Thread the AC supply and DC output connectors through the grommets provided and connect them to the drive.
2. Place the terminal shroud over the top of the connectors and click into place (3).

**Figure 3-19 Removing the terminal shrouds on size 1 drives**



1. Insert the screwdriver as shown.
2. Lever in the direction shown to unclip the terminal shroud and remove.

**Figure 3-20 Installing the terminal shrouds on size 2 drives**



1. Assemble the cable to the busbar.
2. Place the terminal shroud base cover underneath the cable in the orientation shown.
3. Place the terminal shroud over the cable in the orientation shown, slide the terminal shroud on to the base cover in the direction shown until it clicks in to place.
4. For all power connections slide in the terminal shroud sub-assembly in the direction as shown.
5. Insert the 2 x M4 x 16 screws using a pozi drive screwdriver.

**NOTE**

To remove the terminal shrouds, please reverse the process above.

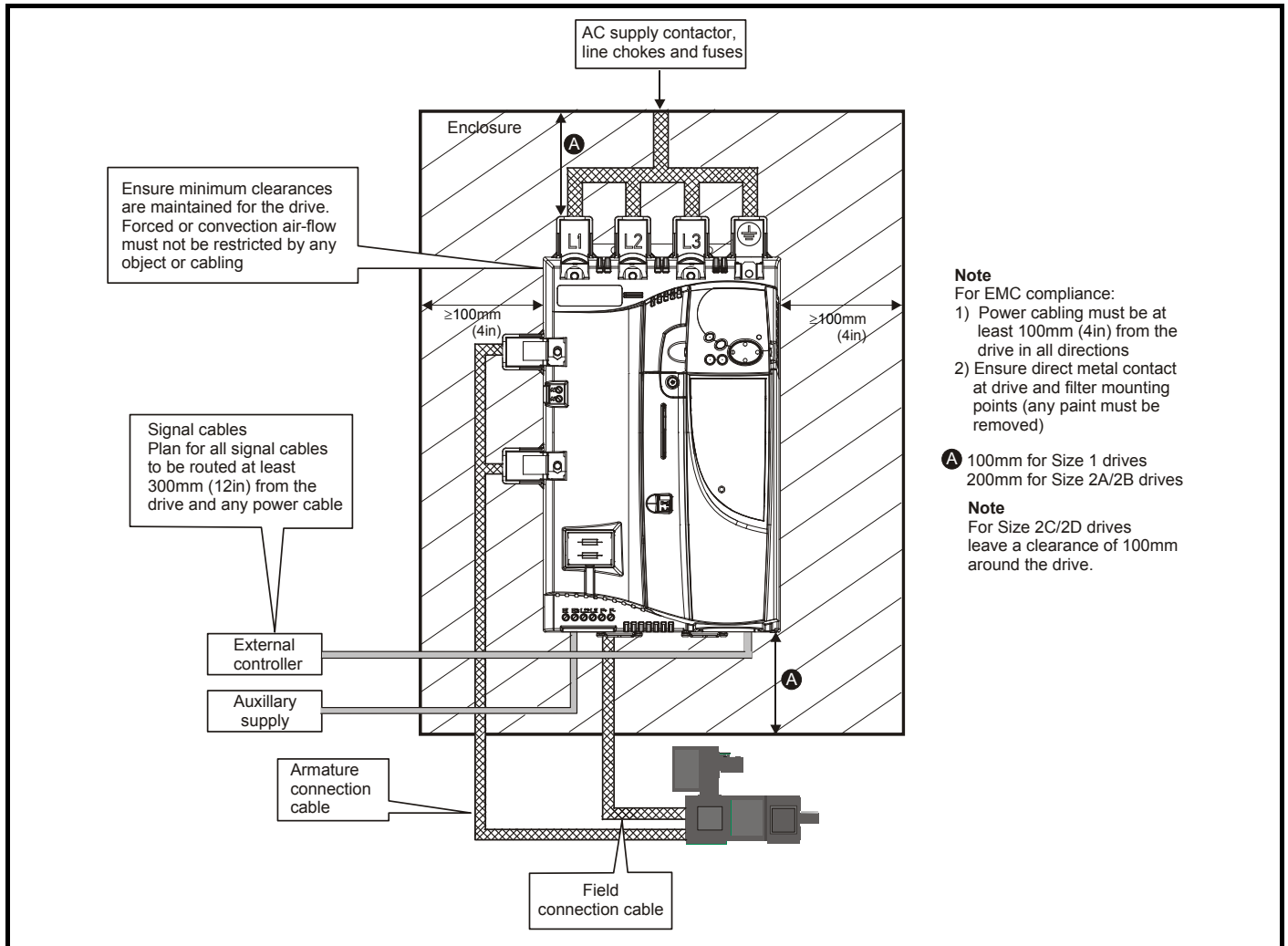


## 3.6 Enclosure

### 3.6.1 Enclosure layout

Please observe the clearances in the diagram below taking into account any appropriate notes for other devices / auxiliary equipment when planning the installation.

Figure 3-21 Enclosure layout



### 3.6.2 Enclosure sizing

Refer to Table 12-4 in section 12.1.4 *Power dissipation* on page 154 for drive losses.

Add the dissipation figures for each drive that is to be installed in the enclosure.

Add the power dissipation figures for each EMC filter that is to be installed in the enclosure.

Calculate the total heat dissipation (in Watts) of any other equipment to be installed in the enclosure.

Add the figures of all of the above to get a total heat dissipation figure (in Watts) for the equipment in the enclosure.

#### Calculating the size of a sealed enclosure

The enclosure transfers internally generated heat into the surrounding air by natural convection. The larger the surface area of the enclosure walls, the better is the dissipation capability. Only the surfaces of the enclosure that are not in contact with a wall or floor can dissipate heat.

Calculate the minimum required unobstructed surface area  $A_e$  for the enclosure from:

$$A_e = \frac{P}{k(T_{int} - T_{ext})}$$

Where:

- $A_e$  Unobstructed surface area in  $m^2$  ( $1 m^2 = 10.9 ft^2$ )
- $T_{ext}$  Maximum expected temperature in  $^{\circ}C$  outside the enclosure
- $T_{int}$  Maximum permissible temperature in  $^{\circ}C$  inside the enclosure
- $P$  Power in Watts dissipated by all heat sources in the enclosure
- $k$  Heat transmission coefficient of the enclosure material in  $W/m^2/^{\circ}C$

#### Example

To calculate the size of an enclosure for the following:

- Two MP25A4 models operating under full load conditions
- Maximum ambient temperature inside the enclosure:  $40^{\circ}C$
- Maximum ambient temperature outside the enclosure:  $30^{\circ}C$

Dissipation of each drive: 125 W

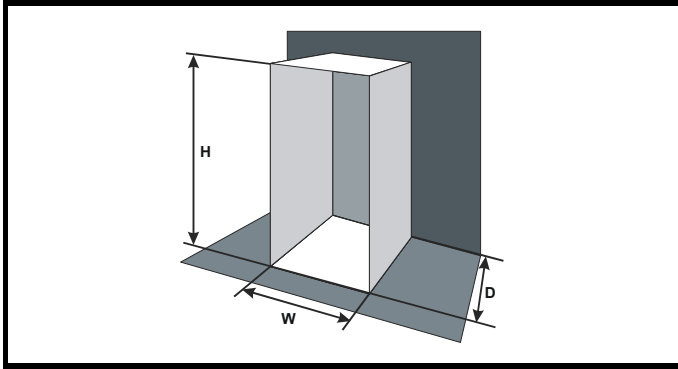
Dissipation from other heat generating equipment in the enclosure. 22 W (max).

Total dissipation:  $(2 \times 125) + 22 = 272 W$ .

The enclosure is to be made from painted 2 mm (0.079 in) sheet steel having a heat transmission coefficient of  $5.5 \text{ W/m}^2/\text{°C}$ . Only the top, front, and two sides of the enclosure are free to dissipate heat.

The value of  $5.5 \text{ W/m}^2/\text{°C}$  can generally be used with a sheet steel enclosure (exact values can be obtained by the supplier of the material). If in any doubt, allow for a greater margin in the temperature rise.

**Figure 3-22 Enclosure having front, sides and top panels free to dissipate heat**



Insert the following values:

$T_{\text{int}}$	40 °C
$T_{\text{ext}}$	30 °C
$k$	5.5
$P$	272 W

The minimum required heat conducting area is then:

$$A_e = \frac{272 \text{ W}}{5.5(40 - 30)}$$

$$= 4.945 \text{ m}^2 (53.90 \text{ ft}^2) \quad (1 \text{ m}^2 = 10.9 \text{ ft}^2)$$

Estimate two of the enclosure dimensions - the height (H) and depth (D), for instance. Calculate the width (W) from:

$$W = \frac{A_e - 2HD}{H + D}$$

Inserting  $H = 2\text{m}$  and  $D = 0.6\text{m}$ , obtain the minimum width:

$$W = \frac{4.945 - (2 \times 2 \times 0.6)}{2 + 0.6}$$

$$= 0.979 \text{ m (38.5 in)}$$

If the enclosure is too large for the space available, it can be made smaller only by attending to one or all of the following:

- Reducing the ambient temperature outside the enclosure, and/or applying forced-air cooling to the outside of the enclosure
- Reducing the number of drives in the enclosure
- Removing other heat-generating equipment

### Calculating the air-flow in a ventilated enclosure

The dimensions of the enclosure are required only for accommodating the equipment. The equipment is cooled by the forced air flow.

Calculate the minimum required volume of ventilating air from:

$$V = \frac{3kP}{T_{\text{int}} - T_{\text{ext}}}$$

Where:

$V$	Air-flow in $\text{m}^3$ per hour ( $1 \text{ m}^3/\text{hr} = 0.59 \text{ ft}^3/\text{min}$ )
$T_{\text{ext}}$	Maximum expected temperature in °C <i>outside</i> the enclosure
$T_{\text{int}}$	Maximum permissible temperature in °C <i>inside</i> the enclosure
$P$	Power in Watts dissipated by <i>all</i> heat sources in the enclosure
$k$	Ratio of $\frac{P_o}{P_i}$

Where:

$P_o$  is the air pressure at sea level

$P_i$  is the air pressure at the installation

Typically use a factor of 1.2 to 1.3, to allow also for pressure-drops in dirty air-filters.

### Example

To calculate the size of an enclosure for the following:

- Three MP45A4 models operating under full load conditions
- Maximum ambient temperature inside the enclosure: 40 °C
- Maximum ambient temperature outside the enclosure: 30 °C

Dissipation of each drive: 168W

Dissipation from other heat generating equipment. 45 W

Total dissipation:  $(3 \times 168) + 45 = 549 \text{ W}$

Insert the following values:

$T_{\text{int}}$	40 °C
$T_{\text{ext}}$	30 °C
$k$	1.3
$P$	549 W

Then:

$$V = \frac{3 \times 1.3 \times 549}{40 - 30}$$

$$= 214.1 \text{ m}^3/\text{hr (126.3 ft}^3/\text{min)} \quad (1 \text{ m}^3/\text{hr} = 0.59 \text{ ft}^3/\text{min)}$$

## 3.7 Heatsink fan operation

Mentor MP drives rated 75 A to 900 A are ventilated by internally supplied fans.

Ensure the minimum clearances around the drive are maintained to allow the air to flow freely. The air flow figures are listed below:

Size 1A - 0.5 cubic metres per minute.

Size 1B - 2.8 cubic metres per minute.

Size 2A - 7.8 cubic metres per minute.

Size 2B - 7.8 cubic metres per minute.

Mentor MP drives rated 1200 A and above are ventilated by externally supplied fans. Please refer to section 4.12 *Connecting the fan on size 2C and 2D drives* on page 55 for more information.


The air flow figures are listed below:

Size 2C - 22 cubic metres per minute.

Size 2D - 22 cubic metres per minute.

The drive controls the fan operation based on the temperature of the heatsink and the drives thermal model system.

## 3.8 IP rating (Ingress Protection)

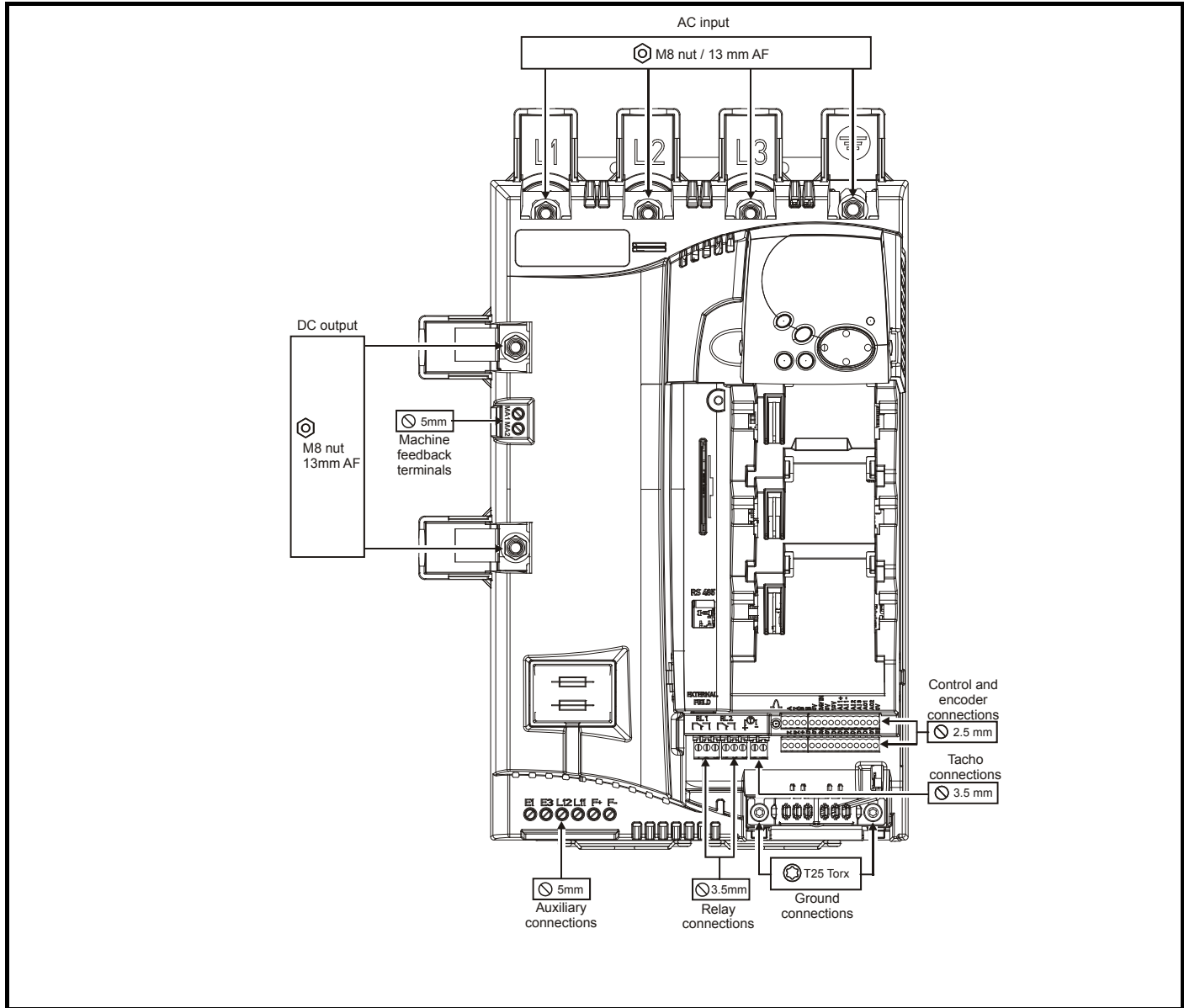
	<p>IP rating</p> <p>It is the installer's responsibility to ensure that any enclosure which allows access to drives from frame sizes 2A to 2D while the product is energized, provides protection against contact and ingress to the requirements of IP20.</p>
---	--

An explanation of IP rating is provided in section 12.1.13 *IP rating* on page 155.

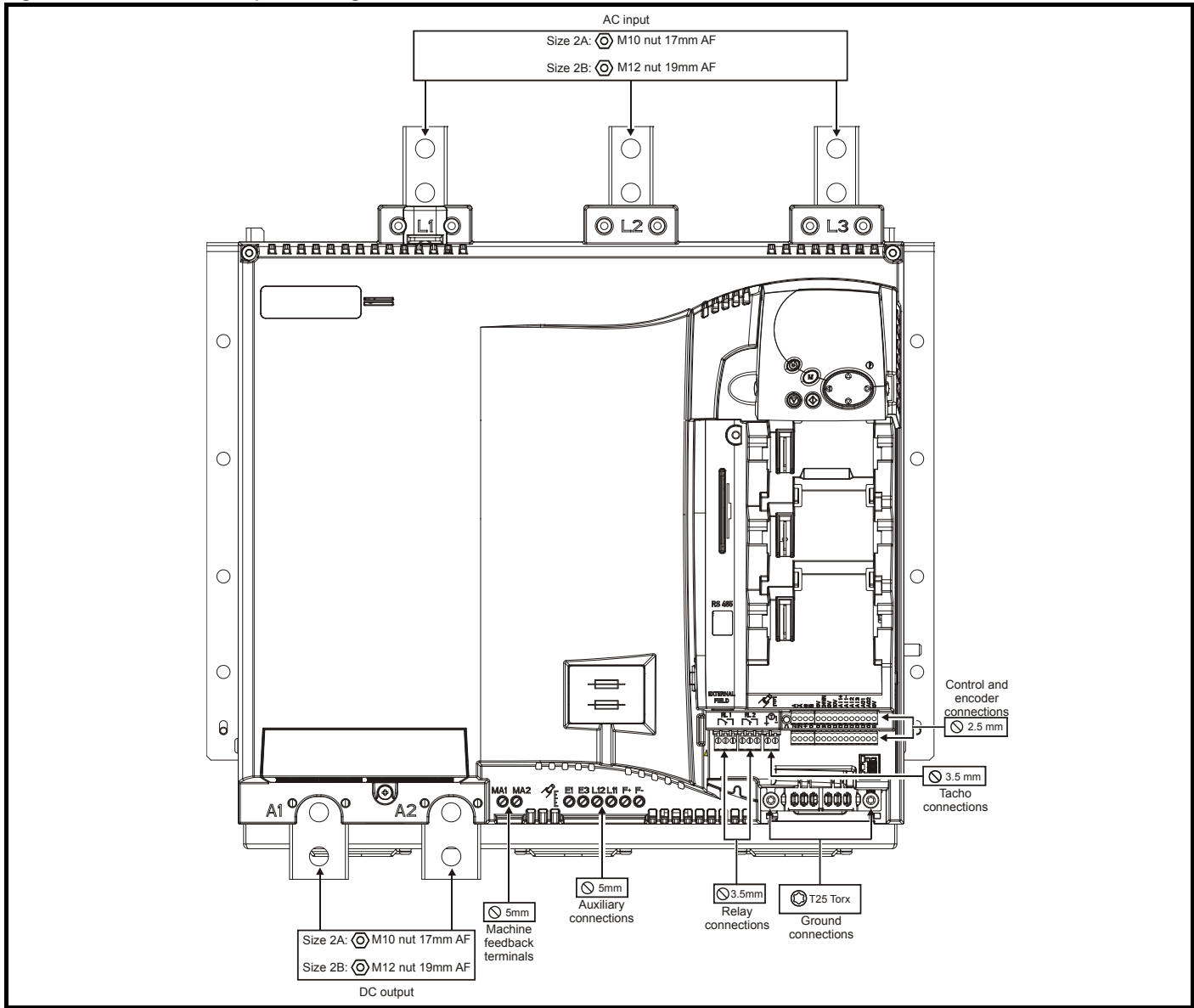
### 3.9 Electrical terminals

#### 3.9.1 Location of the power and ground terminals

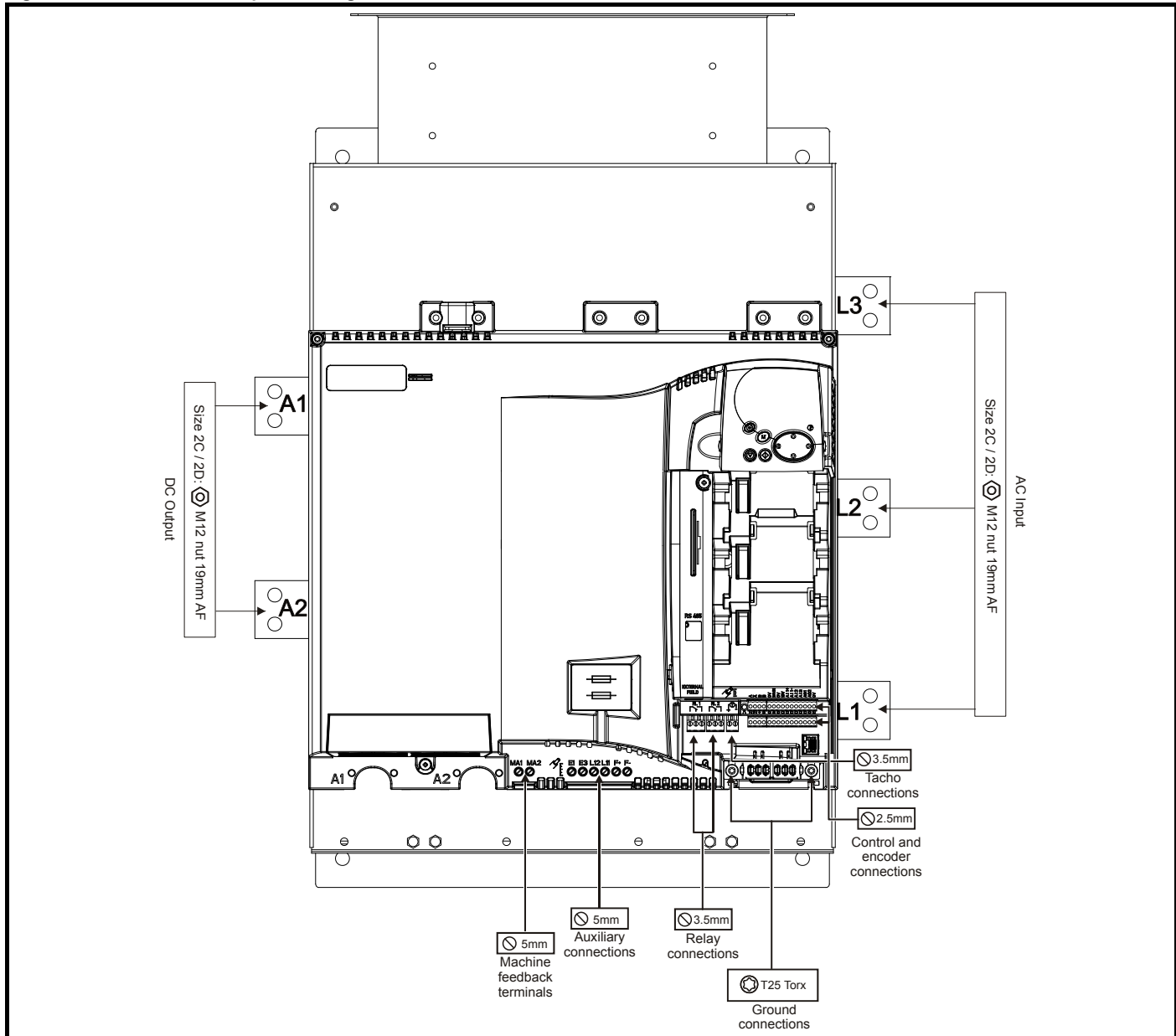
Figure 3-23 Location of the power and ground terminals on size 1 drives



**Figure 3-24 Location of the power and ground terminals on size 2A and 2B drives**



**Figure 3-25 Location of the power and ground terminals on size 2C and 2D drives**



### 3.9.2 Terminal sizes and torque settings

**WARNING** To avoid a fire hazard and maintain validity of the UL listing, adhere to the specified tightening torques for the power and ground terminals. Refer to the following tables.

### 3.9.3 Torque settings

**Table 3-1 Drive control, status relay and encoder terminal data**

Model	Connection type	Torque setting
All	Plug-in terminal block	0.5 N m (4.5 lb in)

**Table 3-2 Drive auxiliary and machine armature terminal data**

Model	Connection type	Torque setting
All	Terminal block	0.5 N m (4.5 lb in)

**Table 3-3 Drive power stage terminals on size 1 drives**

Model	Connection type	Torque setting
All	M8 stud	10 N m (89.0 lb in)

**Table 3-4 Drive power stage terminals on size 2 drives**

Model	Connection type	Torque setting
Size 2A	M10 stud	15 N m (133.0 lb in)
Size 2B	M12 stud	30 N m (266.0 lb in)
Size 2C		
Size 2D		

### 3.10 Routine maintenance

The drive should be installed in a cool, clean, well ventilated location. Contact of moisture and dust with the drive should be prevented.

Regular checks of the following should be carried out to ensure drive / installation reliability are maximized:

<b>Environment</b>	
Ambient temperature	Ensure the enclosure temperature remains at or below maximum specified
Dust	Ensure the drive remains dust free – check that the heatsink and drive fan are not gathering dust. The lifetime of the fan is reduced in dusty environments.
Moisture	Ensure the drive enclosure shows no signs of condensation
<b>Enclosure</b>	
Enclosure door filters	Ensure filters are not blocked and that air is free to flow
<b>Electrical</b>	
Screw connections	Ensure all screw terminals remain tight
Crimp terminals	Ensure all crimp terminals remains tight – check for any discoloration which could indicate overheating
Cables	Check all cables for signs of damage

## 4 Electrical installation

Many cable management features have been incorporated into the product and accessories, this chapter shows how to optimize them. Key features include:

- EMC compliance
- Product rating, fusing and cabling information
- External suppressor resistor details (selection / ratings)



**WARNING**

### Electric shock risk

The voltages present in the following locations can cause severe electric shock and may be lethal:

- AC supply cables and connections
  - DC cables, and connections
  - Many internal parts of the drive, and external option units
- Unless otherwise indicated, control terminals are single insulated and must not be touched.



**WARNING**

### Isolation device

The AC supply must be disconnected from the drive using an approved isolation device before any cover is removed from the drive or before any servicing work is performed.



**WARNING**

### STOP function

The STOP function does not remove dangerous voltages from the drive, the motor or any external option units.



**WARNING**

Drives are suitable for use on supplies of installation category III and lower, according to IEC 60664-1. This means they may be connected permanently to the supply at its origin in a building, but for outdoor installation additional over-voltage suppression (transient voltage surge suppression) must be provided to reduce category IV to category III.



**WARNING**

### Permanent magnet motors

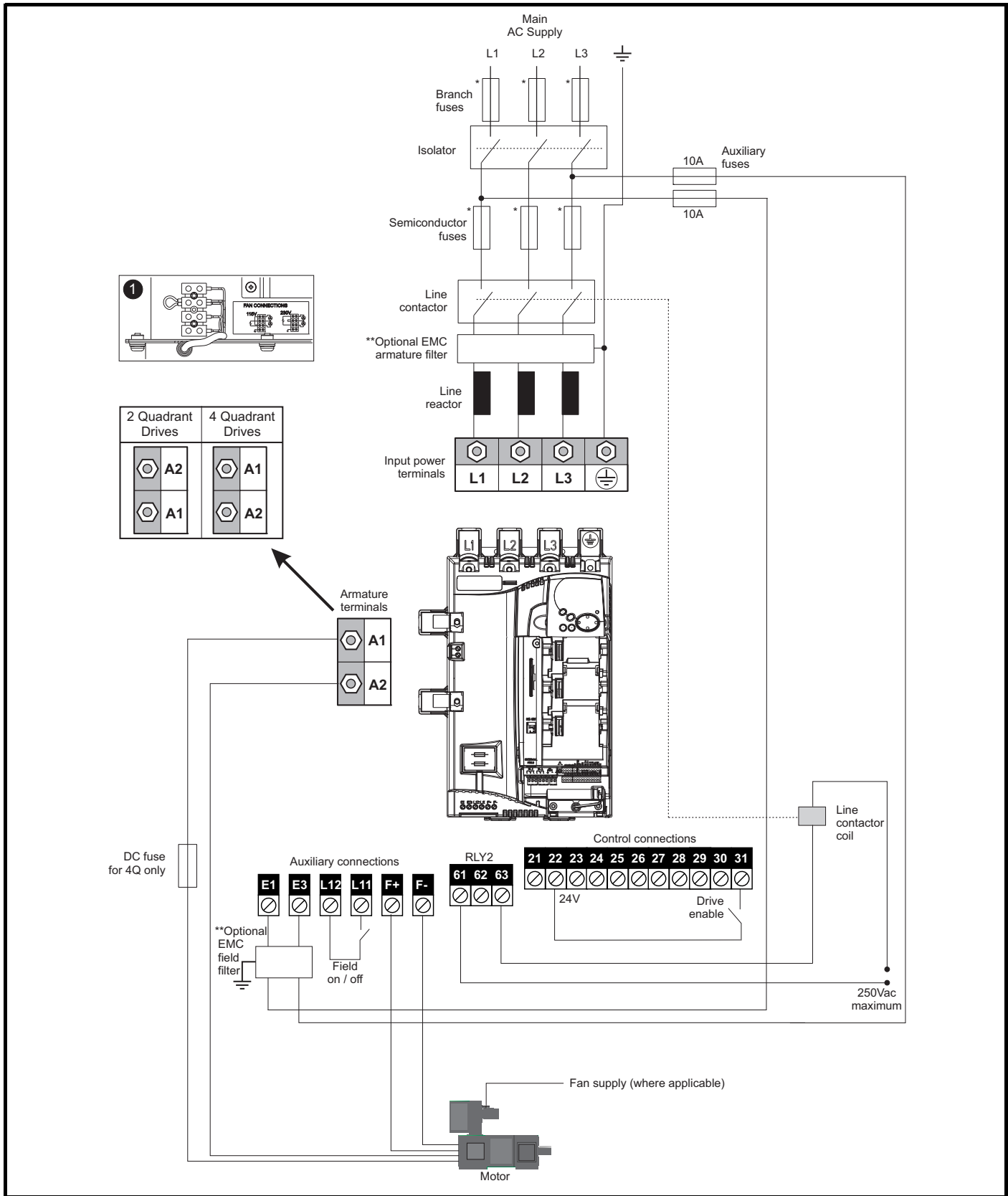
Permanent magnet motors generate electrical power if they are rotated, even when the supply to the drive is disconnected. If that happens then the drive will become energized through its motor terminals.

If the motor load is capable of rotating the motor when the supply is disconnected, then the motor must be isolated from the drive before gaining access to any live parts.

## 4.1 Electrical connections

Refer to Figure 4-1 and Figure 4-2 to understand the function of the different power connections

**Figure 4-1 Power connections for 480 V drive**



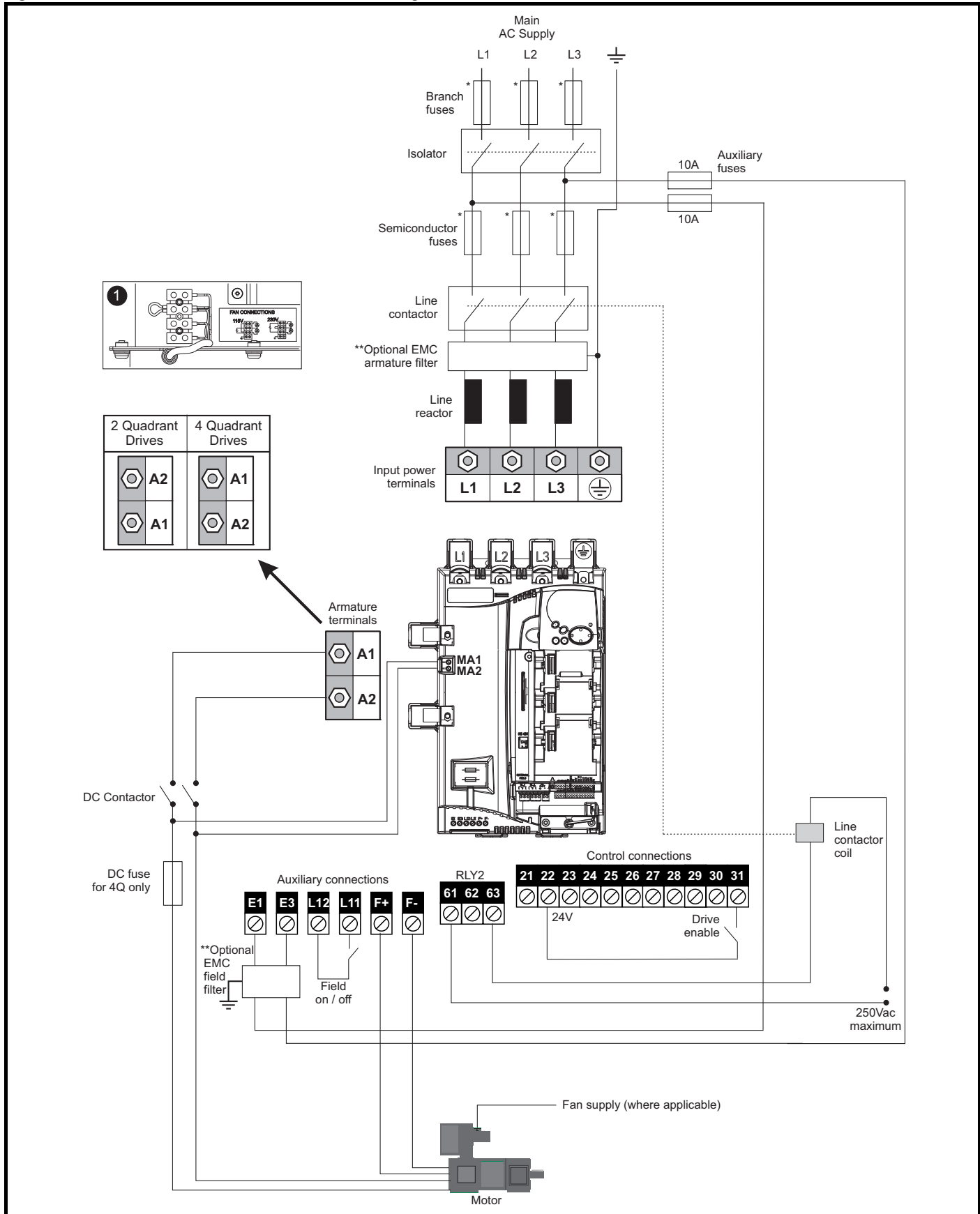
1. End user must provide 230 / 115 Vac supply for the internal fans on frame sizes C and D, see section 4.12 on page 55.

\* For fuse ratings refer to section 4.6 Cable and fuse size ratings on page 42.

\*\* For further information on EMC filters, see section 4.9.3 EMC filter information on page 53.



**Figure 4-2 Power connections for 480 V drive when using DC contactors**

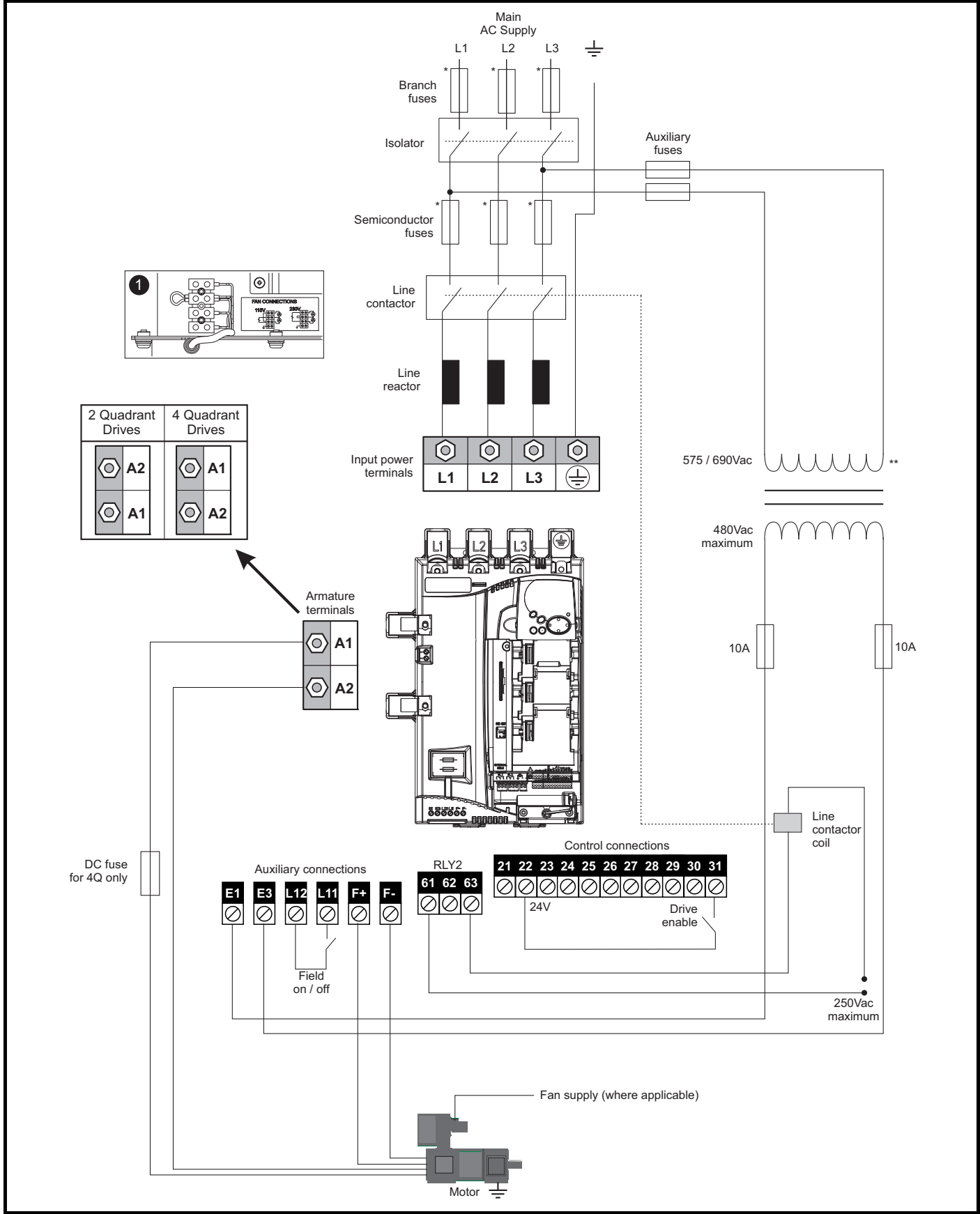


1. End user must provide 230 / 115 Vac supply for the internal fans on frame sizes C and D, see section 4.12 on page 55.

\* For fuse ratings refer to section 4.6 *Cable and fuse size ratings* on page 42.

\*\*For further information on EMC filters, see section 4.9.3 *EMC filter information* on page 53.

**Figure 4-3 Power connections for 575 V / 600 V / 690 V drives**



1. End user must provide 230 / 115 Vac supply for the internal fans on frame sizes C and D, see section 4.12 on page 55.

\* For fuse ratings refer to section 4.6 *Cable and fuse size ratings* on page 42.

\*\* The transformer must have zero phase delay.

## 4.2 Ground connections

The drive must be connected to the system ground of the AC supply. The ground wiring must conform to local regulations and codes of practice.



**Electrochemical corrosion of grounding terminals**  
Ensure that grounding terminals are protected against corrosion i.e. as could be caused by condensation.



**Ground loop impedance**  
The ground loop impedance must conform to the requirements of local safety regulations.  
The drive must be grounded by a connection capable of carrying the prospective fault current until the protective device (fuse, etc.) disconnects the AC supply.  
The ground connections must be inspected and tested at appropriate intervals.

Figure 4-4 Location of ground connection on size 1 drives

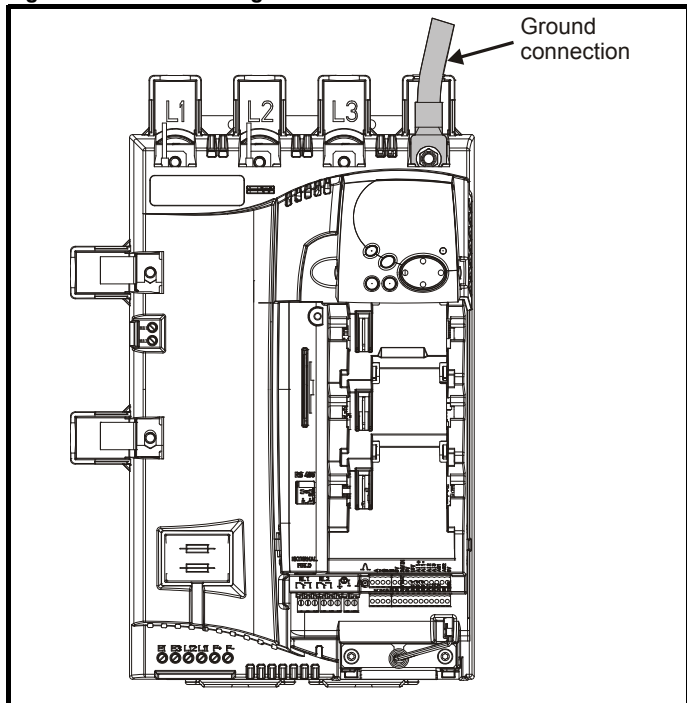


Table 4-1 Protective ground cable ratings

Input phase conductor size	Minimum ground conductor size
$\leq 10 \text{ mm}^2$	Either $10 \text{ mm}^2$ or two conductors of the same cross-sectional area as the input phase conductor
$> 10 \text{ mm}^2$ and $\leq 16 \text{ mm}^2$	The same cross-sectional area as the input phase conductor
$> 16 \text{ mm}^2$ and $\leq 35 \text{ mm}^2$	$16 \text{ mm}^2$
$> 35 \text{ mm}^2$	Half of the cross-sectional area of the input phase conductor

Figure 4-5 Location of ground connections on size 2A / 2B drives

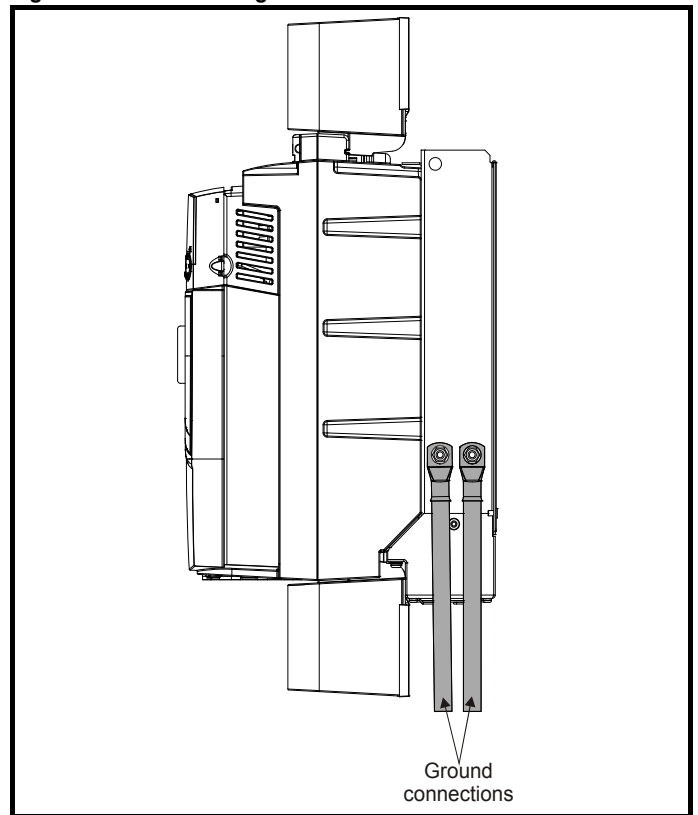
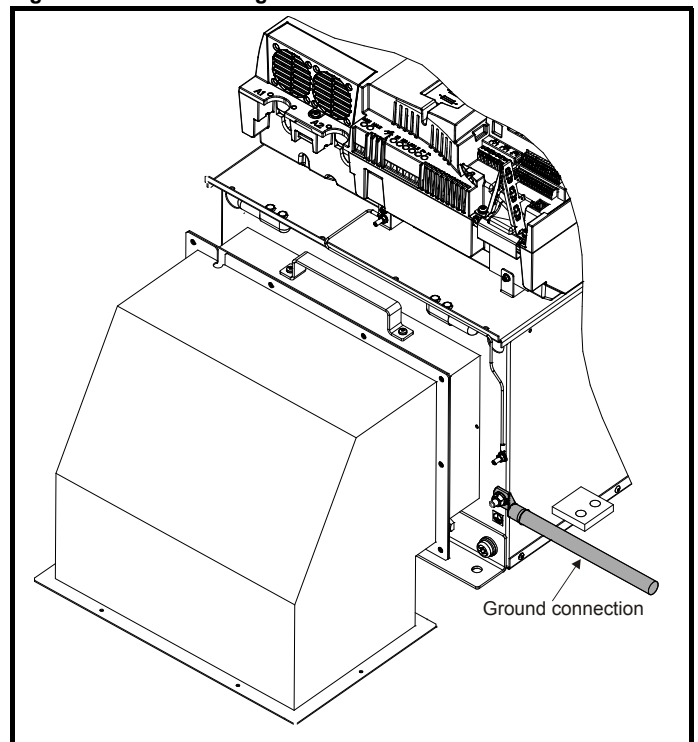


Figure 4-6 Location of ground connections on size 2C / 2D drives




### 4.3 AC supply requirements

The standard drive is rated for a nominal supply voltage up to 480 V rms.

An optional rating of 575 V rms is available for size 1 drives.

An optional rating of 575 V rms and 690 V rms is available for size 2 drives.

	<p>Grounded delta supplies exceeding 575 V are not permitted for drives up to and including 210 A. Grounded delta supplies exceeding 600 V are not permitted for drives rated 350 A and above.</p>
--	--

#### 4.3.1 Supply types

Drives rated for supply voltages of up to 575 V (rated up to 210 A) and 690 V (350 A and above), are suitable for use with any of the following supply types i.e. TN-S, TN-C-S, TT, IT.

Grounded delta supplies <575 V are permitted for drives rated up to and including 210 A. Grounded delta supplies <600 V are permitted for drives rated 350 A and above.

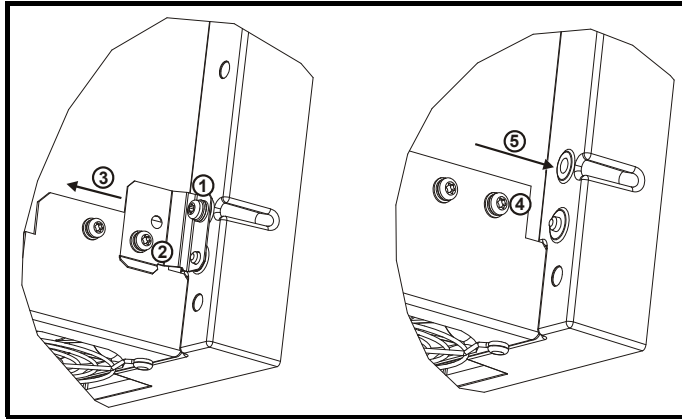
#### 4.3.2 Supply fault current

The maximum fault current level of the supply to all circuits is 100 kA subject to the capability of the semiconductor fuse fitted.

#### 4.3.3 MOV ground disconnect


The facility for disconnecting the jumper (link) between varistors and ground is provided for special circumstances, where a sustained high voltage may be present between lines and ground, for example during a high potential test or in certain situations with IT supplies and multiple generators. If the jumper (link) is disconnected then the immunity of the drive to high voltage impulses is reduced. It is then only suitable for use with supplies having overvoltage category II, i.e. not for connection at the origin of the low voltage supply within a building.

**Figure 4-7 Removing the MOV ground connection on size 1 drives**

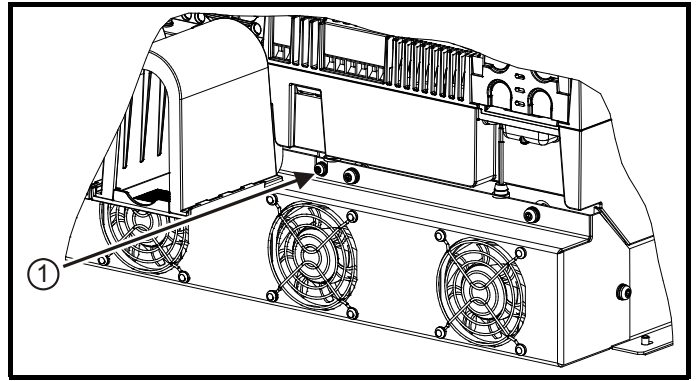


The method for disconnecting the MOV ground connection on size 1 drives is shown below:

1. Remove the M4 x 16 screw using T20 Torx driver.
2. Remove the M4 x 12 screw using T20 Torx driver.
3. Remove the plate.
4. Re-fit the M4 x 12 screw using T20 Torx driver and tighten to a torque of 0.6 N m (0.44 lb ft).
5. Fit a M4 x 16 **nylon screw** (not supplied) and tighten to a torque of 0.25 N m (0.18 lb ft).

	<p>The M4 x 16 screw (1) should not be re-used if the plate (3) is not re-installed. Instead a nylon screw should be used.</p>
--	--

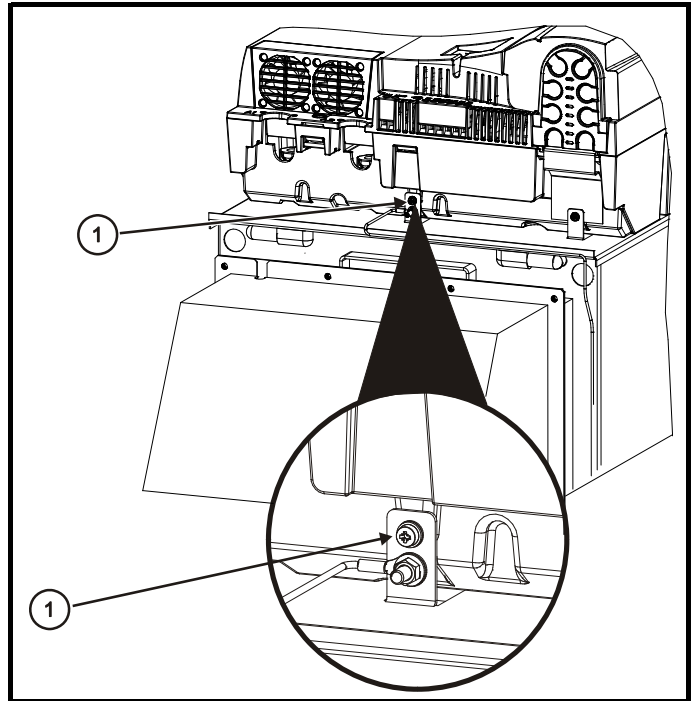
**Figure 4-8 Removing the MOV ground connection on size 2A / 2B drives**



The method for disconnecting the MOV ground connection on size 2A / 2B drives is shown below:

1. Remove the M4 x 30 screw using T20 Torx driver .  
If re-installing the M4 x 30 screw using T20 Torx driver, the screw must be tightened to a torque of 2.5 N m (1.84 lb ft).

**Figure 4-9 Removing the MOV ground connection on size 2C / 2D drives**



The method for disconnecting the MOV ground connection on size 2C / 2D drives is shown in Figure 4-9 above:

1. Remove the M4 x 30 screw using T20 Torx driver .  
If re-fitting the M4 x 30 screw using T20 Torx driver, the screw must be tightened to a torque of 2.5 N m (1.84 lb ft).

### 4.3.4 Main AC supply (L1, L2, L3)

**Table 4-2 Three phase AC supply**

Specification	Product voltage variant		
	480 V	575 V	690 V
Maximum nominal supply	480 V	575 V	690 V
Tolerance	+10 %		
Minimum nominal supply	24 V		
Tolerance	-20 %		

### 4.4 Line reactors

The Mentor MP, in common with all naturally commutated thyristor drives, causes voltage notches at the input supply terminals. In order to avoid disturbance to other equipment using the same supply, the addition of external line inductance is strongly recommended in order to restrict the depth of the notches imposed on the shared supply. This is generally not necessary where a dedicated transformer is used to supply the drive.

The following recommendations for added line inductance, have been calculated based on the power drive systems standard: EN 61800-3:2004 "Adjustable speed electrical power drive systems – Part 3: EMC requirements and specific test methods".

**NOTE**

The current ratings specified in Table 4-3 are for typical motor currents where the motor current ripple is no more than 50 % of drive rating.

**Table 4-3 Minimum required line inductance for a typical application (50 % ripple content)**

Drive rated current A	System voltage				Typical current rating A	Maximum current rating A
	400 V μH	480 V μH	575 V μH	690 V μH		
25	220	260	320		21	22
45	220	260	320		38	40
75	220	260	320		63	67
105	220	260	320		88	94
155	160	190	230		130	139
210	120	140	170		176	188
350	71	85	110	120	293	295
420	59	71			351	350
470			80	91	393	395
550	45	54			460	450
700	36	43	53	61	586	585
825			45	52	690	665
900	28	33			753	725
1200	21	25	31	36	1004	1050
1850	18	23	29	32	1570	1655

**NOTE**

1. The above assumes the supply has 1.5 % impedance.
2. Assumes a minimum supply rating of 5 kA and a maximum rating of 60 kA.

**Table 4-4 Part numbers for ordering Mentor MP Chokes**

Part number	Drive (Model)	Current / Inductance
4499-0021	MP25	21 A / 0,22 mH
4499-0038	MP45	38 A / 0,22 mH
4499-0063	MP75	63 A / 0,22 mH
4499-0088	MP105	88 A / 0,22 mH
4499-0130	MP155	130 A / 0,16 mH
4499-0180	MP210	180 A / 0,12 mH
4499-0290	MP350	290 A / 0,071 mH
4499-0350	MP420	350 A / 0,059 mH
4499-0460	MP550	460 A / 0,045 mH
4499-0590	MP700	590 A / 0,036 mH
4499-0690	MP825	690 A / 0,03 mH
4499-0750	MP900	750 A / 0,028 mH
4499-1000	MP1200	1000 A / 0,021 mH
4499-1548	MP1850	1548 A / 0,018 mH

### 4.4.1 Auxiliary AC supply and connections

**Table 4-5 Terminal functions**

Terminals	Function
E1, E3	Supply for control electronics and field controller.
L11, L12	Field on / off. When L11 and L12 are open the supply is disconnected to the field regulator so there will be no field current.
F+, F-	Field supply to the motor.
MA1, MA2	These terminals are used to provide feedback from the motor armature terminals. This is required when the user has a contactor in the main DC armature connection. When the contactor is opened the drive will still be receiving armature feedback. This allows the field regulator to function correctly when the contactor is open.

**Table 4-6 Line to line supply**

Specification	Value
Maximum nominal supply	480 V
Tolerance	+10 %
Minimum nominal supply	208 V
Tolerance	-10 %

Each drive has an onboard field controller with the following current ratings.

**Table 4-7 Field controller current ratings**

Model			Maximum auxiliary supply input current A	Maximum continuous field current rating A
MP25A4(R)	MP25A5(R)		13	8
MP45A4(R)	MP45A5(R)			
MP75A4(R)	MP75A5(R)			
MP105A4(R)	MP105A5(R)			
MP155A4(R)	MP155A5(R)			
MP210A4(R)	MP210A5(R)			
MP350A4(R)	MP350A5(R)	MP350A6(R)	23	20
MP420A4(R)				
	MP470A5(R)	MP470A6(R)		
MP550A4(R)				
MP700A4(R)	MP700A5(R)	MP700A6(R)		
MP825A4(R)	MP825A5(R)	MP825A6(R)		
MP900A4(R)				
MP1200A4	MP1200A5	MP1200A6		
MP1850A4	MP1850A5	MP1850A6		
MP1200A4R	MP1200A5R	MP1200A6R		
MP1850A4R	MP1850A5R	MP1850A6R		

#### 4.4.2 Supply requirements

Maximum supply in-balance: 2 % negative phase sequence (equivalent to 3 % voltage in-balance between phases)

Frequency range: 45 to 65 Hz (maximum rate of frequency change is 7 Hz/s).

### 4.5 Control 24 Vdc supply

The 24 Vdc input has three main functions.

- It can be used to supplement the drive's own internal 24 V when multiple SM-Universal Encoder Plus, SM-Encoder Output Plus, SM-I/O Plus, or SM-I/O 32 modules are being used and the current drawn by these modules is greater than the drive can supply. (If too much current is drawn from the drive, the drive will initiate a 'PS.24 V' trip).
- It can be used as a back-up power supply to keep the control circuits of the drive powered up when the line power supply is removed. This allows any fieldbus modules, application modules, encoders or serial communications to continue to operate.
- It can be used to commission the drive when the line power supply is not available, as the display operates correctly. However, the drive will be in the UV trip state unless the line power supply is enabled, therefore diagnostics may not be possible. (Power down save parameters are not saved when using the 24 V back-up power supply input).

The working voltage range of the 24 V power supply is as follows:

Maximum continuous operating voltage:	30.0 V
Minimum continuous operating voltage:	19.2 V
Nominal operating voltage:	24.0 V
Minimum start up voltage:	21.6 V
Maximum power supply requirement at 24 V:	60 W
Recommended fuse:	3 A, 50 Vdc

Minimum and maximum voltage values include ripple and noise. Ripple and noise values must not exceed 5 %.

### 4.6 Cable and fuse size ratings



The selection of the correct fuse is essential to ensure the safety of the installation

Maximum continuous input currents are given in section 2.2 *Current ratings* on page 8 to aid the selection of fuses and cabling. The maximum input current is dependent on the ripple content of the output current. A value of 100 % ripple has been assumed for the given ratings.

The cable sizing selected when installing a Mentor MP must comply with the local wiring regulations. The information provided in this section is provided for guidance purposes only.

The power terminals on Mentor MP frame size 1 drives have been designed to accommodate a maximum cable size of 150 mm<sup>2</sup> (350 kcmil) with a temperature of 90 °C (194 °F).

The power terminals on Mentor MP frame size 2A drives have been designed to accommodate a maximum cable size of 2 x 150 mm<sup>2</sup> (2 x 350 kcmil) with a temperature of 75 °C (167 °F).

The power terminals on Mentor MP frame size 2B drives have been designed to accommodate 2 x 240 mm<sup>2</sup> with a temperature of 90 °C (194 °F). The use of cables sized using the US national electrical code as shown in Table 4-10 requires the use of a terminal adaptor.

The power terminals on Mentor MP frame size 2C and 2D drives have been designed for use with busbars. The drive can be used with cables as shown in Table 4-10 with the use of a terminal adaptor.

The actual cable size depends on a number of factors including:

- Actual maximum continuous current
- Ambient temperature
- Cable support, method and grouping
- Cable voltage drop

In applications where the motor used is of a reduced rating, the cable sizing selected can be appropriate for that motor. To protect the motor and the output cabling the drive must be programmed with the correct motor rated current.

#### NOTE

When using reduced cable sizes, the branch circuit protection fuse rating needs to be reduced in line with the cable size selected.

The following table shows typical cable sizes based on USA and International standards, assuming 3 conductors per raceway/conduit, an ambient temperature of 40 °C (104 °F) and applications with high output current ripple content.

**Table 4-8 Typical cable sizes for size 1 drives**

Model		IEC 60364-5-52 <sup>[1]</sup>		UL508C/NEC <sup>[2]</sup>	
		Input	Output	Input	Output
MP25A4(R)	MP25A5(R)	2.5 mm <sup>2</sup>	4 mm <sup>2</sup>	8 AWG	8 AWG
MP45A4(R)	MP45A5(R)	10 mm <sup>2</sup>	10 mm <sup>2</sup>	4 AWG	4 AWG
MP75A4(R)	MP75A5(R)	16 mm <sup>2</sup>	25 mm <sup>2</sup>	1 AWG	1/0 AWG
MP105A4(R)	MP105A5(R)	25 mm <sup>2</sup>	35 mm <sup>2</sup>	1/0 AWG	1/0 AWG
MP155A4(R)	MP155A5(R)	50 mm <sup>2</sup>	70 mm <sup>2</sup>	3/0 AWG	4/0 AWG
MP210A4(R)	MP210A5(R)	95 mm <sup>2</sup>	95 mm <sup>2</sup>	300 kcmil	350 kcmil

#### NOTE

1. The maximum cable size is defined by the power terminal housing using 90 °C (194 °F) rated cables as per Table A.52-5 of the standard.
2. Assumes the use of 75 °C rated cables, as per Table 310.16 of the National Electrical Code.

The use of higher temperature rated cable would allow a reduction on the minimum recommended cable size for Mentor MP shown above.

For high temperature cable sizing, please refer to the data supplied by the manufacturer of the high temperature cable.

**Table 4-9 Auxiliary wiring for size 1 drives**

Frame size	Maximum input current	Continuous output current	IEC 60364-5-52 Table A52-4 Column B2		UL 508C	
			Column B2 derated by 0,87 of PVC at 40		E1, E3 size	F+, F-, L11 & L12 size
			E1, E3 size	F+, F-, L11 & L12 size		
A	A	mm <sup>2</sup>	mm <sup>2</sup>	mm <sup>2</sup>	mm <sup>2</sup>	
1	13	8	2.5	1.5	14 AWG	14 AWG

**Notes for IEC 60364:**

IEC 60364-5-52 use installation method B2, table A.52-4 for three loaded conductors, PVC insulation 30 °C and apply derating factor for 40 °C from table A.52-14 (0.87 for PVC).

**Notes for UL508C:**

Either 60 °C or 75 °C cable can be used. Ampacities as per table 40.3 as described in the UL508C standard.

**Table 4-10 Typical cable sizes for size 2 drives**

Model	Maximum input current	Continuous output current	IEC 60364-5-52 Table A52-12 Column 5 derated by 0.91 for 40 °C XLPE cables (IEC 60364-5-52 table A52-14) and 0.77 for cables bunching (IEC 60364-5-52 table A52-17 item 4)		US National Electrical Code			
			90 °C cables at 40 °C ambient		75 °C cable at 40 °C ambient			
			A	A	Input size mm <sup>2</sup>	Output size mm <sup>2</sup>	Input cables Kcmil	Output cables Kcmil
MP350A4(R)	MP350A5(R)	MP350A6(R)	295	350	120	150	350	400
MP420A4(R)			350	420	150	185	400	500
	MP470A5(R)	MP470A6(R)	395	470	185	240	500	600
MP550A4(R)			450	550	300	2 x 150	2 x 300	2 x 350
MP700A4(R)	MP700A5(R)	MP700A6(R)	585	700	2 x 150	2 x 185	2 x 500	2 x 600
MP825A4(R)	MP825A5(R)	MP825A6(R)	665	825	2 x 185	2 x 240	2 x 600	3 x 350
MP900A4(R)			725	900	2 x 185	2 x 240	3 x 350	3 x 400
MP1200A4(R)	MP1200A5(R)	MP1200A6(R)	1050	1200	2 x 300	3 x 240	3 x 600	4 x 400
MP1850A4(R)	MP1850A5(R)	MP1850A6(R)	1655	1850	4 x 240	4 x 300	*	*

\* Values are beyond the mechanical design of the drive. At this power level it may be prudent to consider bus-bars.

**Notes for IEC 60364:**

**NOTE**

- IEC 60364-5-52 table A 52-12 F method column 5 = Single core cable in free air.
- IEC 60364-5-52 table A52-14 correction factor for ambient air temperature others than 30 °C.
- IEC 60364-5-52 table A52-17 item 4 correction factor for groups of more than one circuit or more than one multi-core cable placed on a single layer on a perforated tray.

**NOTE**

**Notes for US National Electrical Code:**

- Table 310.17 allowable ampacities of single-insulated conducted rated 0 through 2000 V in free air, based on ambient air temperature of 30 °C (87 °F).
- Derating factor of 0.88 is applied for 40 °C to the 75 °C cable column. Table 310.17 is based on 30 °C (86 °F) ambient air temperature.
- NEC 2005 edition table 310.15(B)(2)(a) shows the adjustment factors for more than three current-carrying conductors in a race way or cable, for 4-6 current-carrying conductors 0.80 derating factor is applied.

**Table 4-11 Auxiliary wiring for size 2 drives**

Frame size	Maximum input current	Continuous output current	IEC 60364-5-52 Table A52-4 Column B2		UL 508C	
			Column B2 derated by 0,87 of PVC at 40		E1, E3 size	F+, F-, L11 & L12 size
			E1, E3 size	F+, F-, L11 & L12 size		
A	A	mm <sup>2</sup>	mm <sup>2</sup>	mm <sup>2</sup>	mm <sup>2</sup>	
2	23	20	6	4	10 AWG	10 AWG


**Notes for IEC 60364:**

IEC 60364-5-52 use installation method B2, table A.52-4 for three loaded conductors, PVC insulation 30 °C and apply derating factor for 40 °C from table A.52-14 (0.87 for PVC).



**Notes for UL508C:** Either 60 °C or 75 °C cable can be used. Ampacities as per table 40.3 as described in the UL508C standard.

### 4.6.1 Ferraz Shawmut fuses



**Fuses**  
The AC supply to the drive must be installed with suitable protection against overload and short-circuits. The following tables show the recommended fuses. Failure to observe this requirement will cause risk of fire.

**WARNING**

Ferraz Shawmut fuses are recommended for the Mentor MP.

**Table 4-12 Ferraz Shawmut semiconductor fusing for size 1 drives**

Model	International				USA				
	Description	Catalog No.	Ref No.	UL app	Description	Catalog No.	Ref No.	UL app	
Field fuses	10 x 38 mm Ferrule	FR10GB69V12.5	H330011	√	10 x 38 mm Ferrule	FR10GB69V12.5	H330011	√	
MP25A4	22 x 58 mm Ferrule	FR22GC69V32	A220915	√	A50QS Series round fuse	A50QS40-4	Y215583	√	
MP25A5									
MP45A4		FR22GC69V63	X220912	√	A50QS Series round fuse	A50QS70-4	B222664	√	
MP45A5									
MP75A4		FR22GC69V100	W220911	√	A50QS Series round fuse	A50QS125-4	K218417	√	
MP75A5									
MP25A4R		FR22GC69V32	A220915	√	A70QS Series round fuse	A70QS60-4	H219473		
MP25A5R									
MP45A4R		FR22GC69V63	X220912	√	A70QS Series round fuse	A70QS80-4	X212816		
MP45A5R									
MP75A4R		FR22GC69V100	W220911	√	A70QS Series round fuse	A70QS125-4	Q216375		
MP75A5R									
MP105A4		Size 30 Square body fuse	PC30UD69V160EF	M300092	√	A50QS Series round fuse	A50QS175-4	A222663	√
MP105A5									
MP155A4	PC30UD69V200EF		N300093	√	A50QS Series round fuse	A50QS250-4	W211251	√	
MP155A5									
MP210A4	PC30UD69V315EF		Q300095	√	A50QS Series round fuse	A50QS350-4	T215343	√	
MP210A5									
MP105A4R	Size 70 Square body fuse	PC70UD13C160EF	T300604	√	A70QS Series round fuse	A70QS175-4	A223192		
MP105A5R									
MP155A4R		PC70UD13C200EF	V300605	√	A70QS Series round fuse	A70QS250-4	L217406		
MP155A5R									
MP210A4R		PC70UD12C280EF	L300712	√	A70QS Series round fuse	A70QS350-4	M211266		
MP210A5R									

**NOTE**

A50QS series are only rated up to 500 Vac.



**Table 4-13 Ferraz Shawmut branch circuit protection fusing for size 1 drives**

Model		International				USA	
		Description	Catalog No.	Ref No.	UL app	Catalog No.	UL app
Auxiliary		21 x 57 mm Cylindrical	HSJ15	D235868		AJT10	√
MP25A4	MP25A5	22 x 58 mm Ferrule	FR22GG69V25	N212072		AJT30	√
MP45A4	MP45A5		FR22GG69V50	P214626		AJT45	√
MP75A4	MP75A5		FR22GG69V80	Q217180		AJT70	√
MP25A4R	MP25A5R		FR22GG69V25	N212072		AJT30	√
MP45A4R	MP45A5R		FR22GG69V50	P214626		AJT45	√
MP75A4R	MP75A5R		FR22GG69V80	Q217180		AJT70	√
MP105A4	MP105A5		NH 00 Knife Blade	NH00GG69V100	B228460		AJT125
MP155A4	MP155A5	NH 1 Knife Blade	NH1GG69V160	F228487		AJT175	√
MP210A4	MP210A5		NH1GG69V200	G228488		AJT225	√
MP105A4R	MP105A5R	NH 00 Knife Blade	NH00GG69V100	B228460		AJT125	√
MP155A4R	MP155A5R	NH 1 Knife Blade	NH1GG69V160	F228487		AJT175	√
MP210A4R	MP210A5R		NH1GG69V200	G228488		AJT225	√

**Table 4-14 Ferraz Shawmut DC Semiconductor protection fusing for size 1 drives**

Model	International				USA			
	Description	Catalog No.	Ref No.	UL app	Description	Catalog No.	Ref No.	UL app
MP25A4R	20 x 127 mm Cylindrical	FD20GB100V32T	F089498		A70QS Series round fuse	A70QS60-4	H219473	√
MP25A5R								
MP45A4R	36 x 127 mm Cylindrical	FD36GC100V80T	A083651		A70QS Series round fuse	A70QS80-4	X212816	√
MP45A5R								
MP75A4R	20 x 127 mm Cylindrical	FD20GC100V63T x 2 connected in parallel	F083656		A70QS Series round fuse	A70QS125-4	Q216375	√
MP75A5R								
MP105A4R	Size 120 Square body	D120GC75V160TF	R085253		A70QS Series round fuse	A70QS175-4	A223192	√
MP105A5R								
MP155A4R	Size 121 Square body	D121GC75V250TF	Q085252		A70QS Series round fuse	A70QS250-4	L217406	√
MP155A5R								
MP210A4R	Size 122 Square body	D122GC75V315TF	M085249		A70QS Series round fuse	A70QS350-4	M211266	√
MP210A5R								

**NOTE**

The above DC fuse recommendations are not required for UL conformity of the Mentor MP drive. Any installations required to meet NEC and/or UL508a panel requirements, must use recognized fuses that meet the requirements of the standard being applied. The UL columns above indicate whether the recommended fuse is a UL recognized component and not its conformance to either NEC or UL508a.

DC fusing is required on four quadrant (R) drives only.

**Table 4-15 Ferraz Shawmut semiconductor fusing for size 2 drives**

Model	International				USA			
	Description	Catalog No.	Ref No.	UL app	Description	Catalog No.	Ref No.	UL app
Field fuses (all size 2)	10 x 38 mm Ferrule	FR10GR69V25	F1014581	√	10 x 38 mm Ferrule	FR10GR69V25	F1014581	√
		FR10GB69V25	L330014			FR10GB69V25	L330014	
MP350A4	Square body fuses	PC30UD69V500TF	W300399	√	American round fuses	A50QS450-4	E216871	√
MP350A4R		PC71UD11V500TF	F300523	√		A70QS450-4	F214848	√
MP350A5		PC31UD69V500TF	T300006	√		A70QS450-4	F214848	√
MP350A6		PC31UD69V500TF	T300006			A70QS450-4	F214848	
MP350A5R		PC72UD13C500TF	D300498	√		A70QS450-4	F214848	√
MP350A6R		PC72UD13C500TF	D300498			A70QS450-4	F214848	
MP420A4		PC32UD69V630TF	M300069	√		A50QS600-4	Q219457	√
MP420A4R		PC272UD13C630TF	W300721	√		A70QS600-4	Y219993	√
MP470A5		PC272UD13C700TF	X300722	√		A70QS600-4	Y219993	√
MP470A6		PC272UD13C700TF	X300722			2 x A70QS400 in parallel	J214345 (x2)	
MP470A5R		PC272UD13C700TF	X300722	√				
MP470A6R		PC272UD13C700TF	X300722					
MP550A4		PC33UD69V700TF	Y300079	√		A50QS700-4	N223181	√
MP550A4R		PC272UD13C700TF	X300722	√		A70QS700-4	E202772	√
MP700A4		PC32UD69V1000TF	S300074	√		A70QS700-4	E202772	√
		PC72UD10C900TF	G300869	√		A50QS900-4	R212282	√
MP700A4R		PC32UD69V1000TF	S300074	√		2 x A70QS500-4 in parallel	A218431 (x2)	
MP700A5		PC32UD69V1000TF	S300074	√				
MP700A6		PC32UD69V1000TF	S300074			2 x A70QS500 in parallel	A218431 (x2)	
MP700A5R		PC73UD12C900TF	T300512	√				
MP700A6R	PC73UD12C900TF	T300512						
MP825A4	PC32UD69V1100TF	M300759	√	A50QS1200-4	C217904	√		
MP825A5	PC33UD69V1100TF	C300083	√	2 x A70QS600-4 in parallel	Y219993 (x2)			
MP825A6	PC33UD69V1100TF	C300083						
MP825A4R	PC73UD95V800TFB	W300514	√	2 x A70QS600-4 in parallel	Y219993 (x2)			
MP825A5R	PC73UD95V800TFB	W300514						
MP825A6R	PC73UD95V800TFB	W300514						
MP900A4	PC33UD69V1250TF	D300084	√	A50QS1200-4	C217904	√		
MP900A4R	PC73UD95V800TFB	W300514	√	2 x A70QS600-4 in parallel	Y219993 (x2)			
MP1200A4	PC33UD60V1600TF	Z300586		2 x A70QS600-4 in parallel	Y219993 (x2)			
	A075URD44PPASF2400	K235184	√	2 x A50QS800-4 in parallel	C202287 (x2)			
				2 x A70QS800-4 in parallel	Z213830 (x2)			

Model	International				USA						
	Description	Catalog No.	Ref No.	UL app	Description	Catalog No.	Ref No.	UL app			
MP1200A4R	Square body fuses	PC273UD11C16CTF	J302228		American round fuses	2 x A70QS800-4 in parallel	Z213830 (x2)				
		A075URD44PPASF2400	K235184	√							
MP1200A5		PC232UD69V16CTD	W300215								
		A075URD44PPASF2400	K235184	√							
MP1200A6		PC232UD69V16CTD	W300215								
		PC273UD11C16CTF	J302228								
MP1200A5R		A075URD44PPASF2400	K235184	√							
		PC273UD11C16CTF	J302228								
MP1200A6R		A075URD44PPASF2400**	K235184	√							
MP1850A4									2 x A50QS1000-4 in parallel.	B217391 (x2)	
MP1850A4R									3 x A70QS700-4 in parallel.	*E202772 (x3)	
MP1850A5									*3 x A70QS700-4 in parallel	*E202772 (x3)	
MP1850A6											
MP1850A5R											
MP1850A6R											

**NOTE**

A50QS series are only rated up to 500 Vac.

\*Application overload limited to infrequent overloads to avoid fuse wear out

\*\*Fuse limits applications to those operating at rated current. No cyclic overloads permitted.

**Table 4-16 Ferraz Shawmut branch circuit protection fusing for size 2 drives**

Model	International				USA					
	Description	Catalog No.	Ref No.	UL app	Description	Catalog No.	Ref No.	UL app		
Auxiliary	25 A 600 Vac High Speed Class J	HSJ205	G235871J	√	25 A 600 Vac High Speed Class J	AJT25R	X21160J	√		
MP350A4(R)	MP350A5(R) MP350A6(R)	General purpose IEC (square body)	NH2GG69V355	Y228503	General purpose US (round body)	A6D400R	B216776	√		
MP420A4(R)	NH3GG69V400		D228508	A6D500R		P217294	√			
MP470A5(R)	NH4GG69V630-8 NH4AGG69V630-8		E215537 W222107	A6D600R		T217804	√			
MP470A6(R)	NH4GG69V630-8		E215537							
MP550A4 (R)	NH4AGG69V630-8		W222107	A4BQ800		Z219373	√			
MP700A4(R)	MP700A5(R) MP700A6(R)		NH4GG69V800-8					K216554		
MP825A4(R)	NH4AGG69V800-8		M222858					A4BQ1000	P216282	√
MP825A5(R)	NH4GG69V800-8 NH4AGG69V800-8		K216554 M222858							
MP825A6(R)										
MP900A4(R)								A4BQ1200	R216790	√
MP1200A4(R)	MP1200A5(R) MP1200A6(R)		General Purpose IEC (round body)	MF76GG69V1250		E302753	A4BQ2000	B223101	√	
MP1850A4(R)	MP1850A5(R) MP1850A6(R)			MF114GG69V2000		G302755				

**NOTE**

USA fuses are only rated up to 600 Vac.

**Table 4-17 Ferraz Shawmut DC protection fusing for size 2 drives**

Model	International				USA				
	Description	Catalog No.	Ref No.	UL recog	Description	Catalog No.	Ref No.	UL recog	
MP350A4R	Square Body fuse	D123GB75V630TF	C098557		American round fuse	A70QS600-4	Y219993	✓	
MP350A5R						A100P600-4	A217373	✓	
MP350A6R						A70QS800-4	Z213830	✓	
MP420A4R		D123GB75V800TF	J220946		American round fuses 2 in parallel	A100P1000-4 (x2)	Y217371 (x2)		
MP470A5R		D2122GD75V900TF	T220955			A70QS450-4 (x2)	F214848 (x2)	✓	
MP470A6R						A70QS600-4 (x2)	Y219993 (x2)	✓	
MP550A4R		D2123GB75V12CTF	D098558			American round fuse	A100P1200-4	N218397	
MP700A4R						American round fuses 2 in parallel	A70QS800-4 (x2)	Z213830 (x2)	
MP700A5R							American round fuse	A100P1200-4	N218397
MP700A6R						American round fuses 2 in parallel	A70QS800-4 (x2)	Z213830 (x2)	
MP825A4R							American round fuse	A100P1200-4	N218397
MP825A5R						American round fuses 3 in parallel	A70QS600-4 (x3)	Y219993 (x3)	
MP825A6R		A70QS700-4 (x3)	E202772 (x3)						
MP900A4R		D2123GB75V14CTF	B090483		American round fuses 3 in parallel	A100P700-4 (x3)	T223163 (x3)		
MP1200A4R		Square body fuses 3 in parallel	PC73UD13C630TF (x3)	Q300509 (x3)		American round fuses 3 in parallel	A70QS600-4 (x5)	Y219993 (x5)	
MP1200A5R							A100P600-4 (x5)	A217373 (x5)	
MP1200A6R	A70QS600-4 (x5)						Y219993 (x5)		
MP1850A4R	Square body fuses 4 in parallel	PC73UD13C700TF (x4)	R300510 (x4)		American round fuses 5 in parallel	A70QS600-4 (x5)	Y219993 (x5)		
MP1850A5R						A100P600-4 (x5)	A217373 (x5)		
MP1850A6R						A70QS600-4 (x5)	Y219993 (x5)		

**NOTE**

The above DC fuse recommendations are not required for UL conformity of the Mentor MP drive. Any installations required to meet NEC and/or UL508a panel requirements, must use recognized fuses that meet the requirements of the standard being applied. The UL columns above indicate whether the recommended fuse is a UL recognized component and not its conformance to either NEC or UL508a.

The use of the A100P series fuses is limited to applications with L/R time constants of 30 ms or less. DC fusing is only required on four quadrant (R) drives.

**4.6.2 Alternative fusing**

Please refer to section 12.2.2 *Alternative fusing* on page 164.

**Table 4-18 Mentor MP size 1 drive thyristor I<sup>2</sup>t rating for semiconductor fusing**

Model		Thyristor I <sup>2</sup> t (A <sup>2</sup> s)	Latching current IL (mA)	Holding current IH (mA)
Field regulator		400		
MP25A4	MP25A5	1030	450	200
MP45A4	MP45A5	3600		
MP75A4	MP75A5	15000		
MP25A4(R)	MP25A5(R)	1030		
MP45A4(R)	MP45A5(R)	3600		
MP75A4(R)	MP75A5(R)	15000		
MP105A4	MP105A5	80000	300	200
MP155A4	MP155A5			
MP210A4	MP210A5			
MP105A4(R)	MP105A5(R)			
MP155A4(R)	MP155A5(R)			
MP210A4(R)	MP210A5(R)			

**Table 4-19 Mentor MP size 2 drive thyristor I<sup>2</sup>t ratings for semiconductor fusing**

Model	Thyristor I <sup>2</sup> t (A <sup>2</sup> s)	Latching current IL (mA)	Holding current IH (mA)
Field regulator	400		
MP350A4(R) MP550A4(R) MP420A4(R)	320000	200	150
MP350A6(R) MP470A6(R) MP470A5(R)	281000	300 - 2000	150 - 500
MP700A4(R) MP900A4(R) MP825A4(R)	1050000		
MP700A6(R) MP825A6(R) MP825A5(R)	1200000		
MP1200A4(R) MP1200A6(R) MP1200A5(R) MP1850A4(R) MP1850A6(R) MP1850A5(R)	2720000	2000	1000

When using Mentor MP to control a high impedance load such as a high current motor field winding, it becomes necessary to connect a resistor across the A1 / A2 terminals to ensure sufficient current flows.

The required resistor value can be calculated as follows:

1. Determine the required output voltage
2. Calculate  $R = V / I_L$
3. Calculate  $P = I_L^2 \times R$  to find the power rating

Example:

If  $V = 200$  V and the required output current is 210 A,  
then  $R = 200$  V / 300 mA = 666  $\Omega$   
and  $P = 300$  mA<sup>2</sup> x 666 = 60 W

### 4.6.3 Internal field fuses

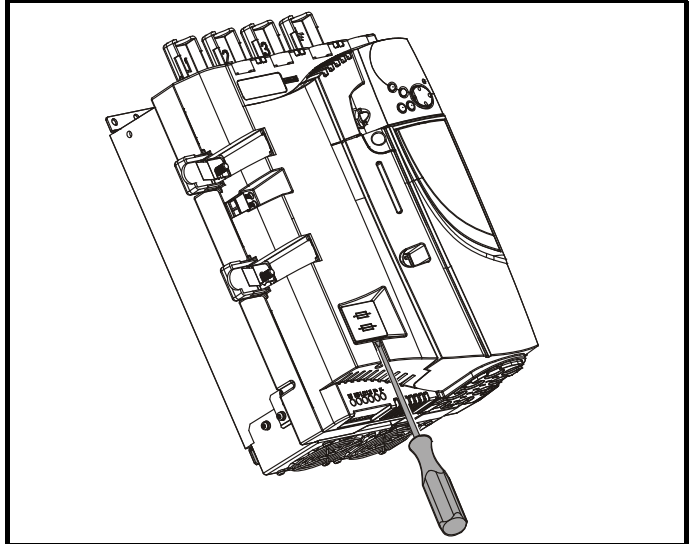
The internal field fuses provide protection to the field controller. The fuses can rupture if there is a fault in the field circuit. The user should check the internal field fuses if the drive is tripping field loss (FdL) and the field controller is enabled.



Isolate the power before removing the internal field fuses.

**WARNING**

**Figure 4-10 Removing the internal field fuses**



Insert a flat-head screwdriver into the groove as shown above and lever downwards to remove the fuse cover. Refer to section 4.6.1 *Ferraz Shawmut fuses* on page 44 for fuse types.

## 4.7 External suppressor resistor

The Mentor MP range of drives provide internal suppression of the voltage overshoots created by commutation of the thyristors in the power stage during the operation of the product. The internal suppression is suitable for typical applications using recommended line reactors as defined in section 4.4 *Line reactors* on page 41. The Mentor MP drives provide the facility to allow for extra suppression for applications at the boundaries of the drive's operating area. Applications which may require an external suppression resistor to be installed have some or all the following characteristics:

1. Supplies rated  $\geq 10$  kA with less than the recommend line reactance.
2. High line-to-line voltage

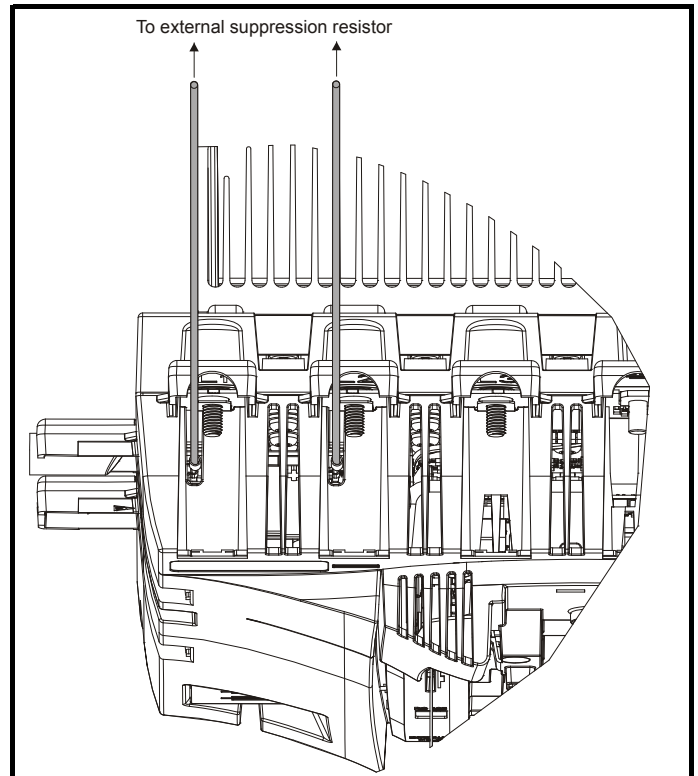
The recommended external suppressor resistor selections are shown in Table 4-20.

**Table 4-20 Recommended external suppressor resistors**

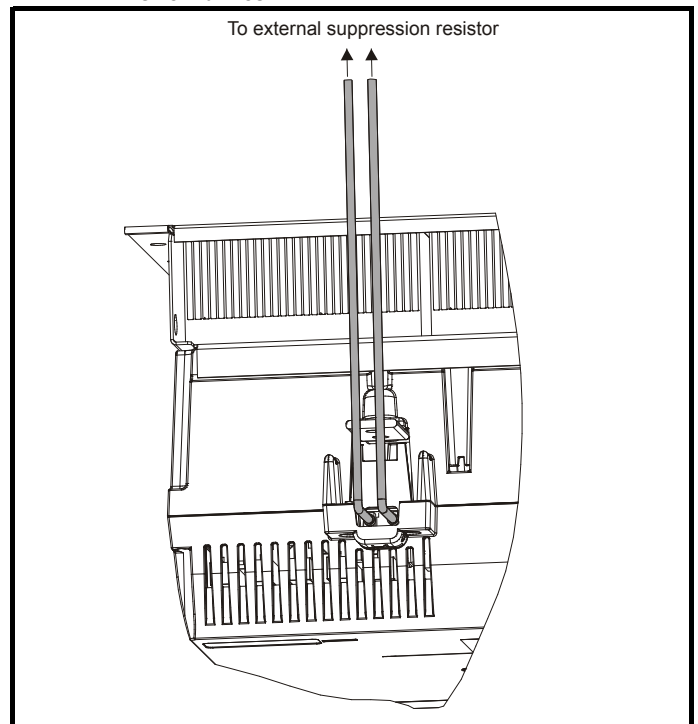
Model	Resistance k $\Omega$	Power rating W	Voltage rating V	Isolation voltage V rms
MP25A4(R)	8.2	150	1100	2500
MP45A4(R)				
MP75A4(R)				
MP105A4(R)				
MP155A4(R)				
MP210A4(R)				
MP25A5(R)	9.9	200	1400	2500
MP45A5(R)				
MP75A5(R)				
MP105A5(R)				
MP155A5(R)				
MP210A5(R)				
MP350A4(R)	4.1	300	1100	2500
MP420A4(R)				
MP550A4(R)				
MP700A4(R)				
MP825A4(R)				
MP900A4(R)				
MP1200A4(R)				
MP1850A4(R)				
MP350A5(R)	8.6	300	1600	2500
MP350A6(R)				
MP470A5(R)				
MP470A6(R)				
MP700A5(R)				
MP700A6(R)				
MP825A5(R)				
MP825A6(R)				
MP1200A5(R)				
MP1200A6(R)				
MP1850A5(R)				
MP1850A6(R)				

The following diagram shows the location of the external suppressor resistor terminals above the L1 and L2 terminals:

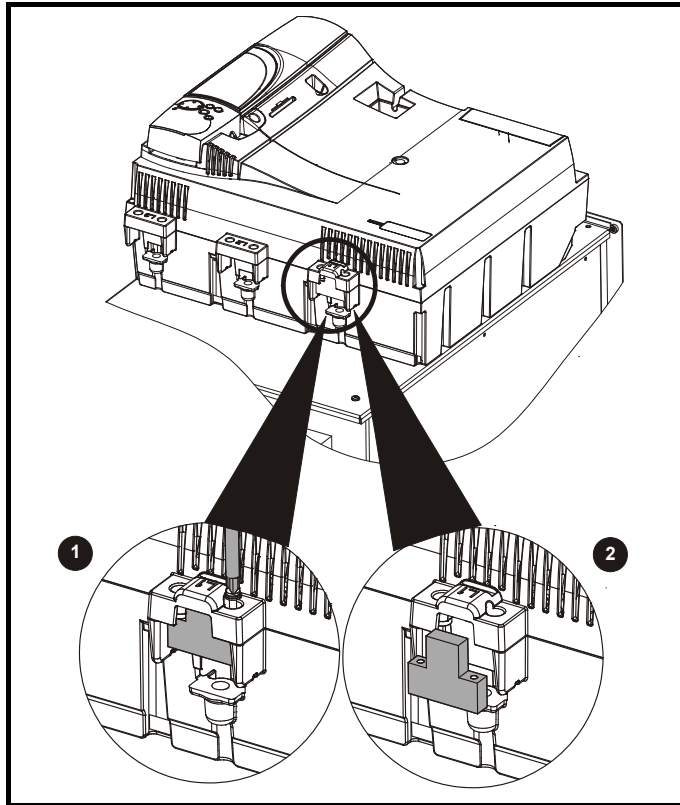
**Figure 4-11 Location of external suppressor resistor terminals on size 1 drives**



**Figure 4-12 Location of external suppressor resistor terminals on size 2 drives**



**Figure 4-13 Removal of bucket suppressor terminals cover on size 2C and 2D**



1. Remove the 2 x M4 x 16 screws using a pozi drive screwdriver.
2. Remove the bucket suppressor terminal cover.

Shielded cable should be used for bucket suppressor connections. For UL applications the cable should comply with UL1063 in accordance with UL508a.

For applications where the external suppressor resistance is chosen to be less than the recommended value for reasons of economy, it is essential that the resistance is not less than the minimum resistance shown in Table 4-21. However selecting a resistance less than the recommended value requires a more complex installation. The power rating of the resistor can be selected by the user according to the dissipation required for the application, up to a maximum of the values specified in Table 4-21.

**Table 4-21 Minimum allowable external suppression resistance**

Model		Resistance $\Omega$
MP25A4(R)	MP25A5(R)	500 (maximum 150 W)
MP45A4(R)	MP45A5(R)	
MP75A4(R)	MP75A5(R)	
MP105A4(R)	MP105A5(R)	
MP155A4(R)	MP155A5(R)	
MP210A4(R)	MP210A5(R)	
MP350A4(R)	MP350A5(R) MP350A6(R)	500 (maximum 300 W)
MP420A4(R)	MP470A5(R) MP470A6(R)	
MP550A4(R)		
MP700A4(R)	MP700A5(R) MP700A6(R)	
MP825A4(R)	MP825A5(R) MP825A6(R)	
MP900A4(R)		
MP1200A4(R)	MP1200A5(R) MP1200A6(R)	
MP1850A4(R)	MP1850A5(R) MP1850A6(R)	



**Overload Protection**

When using an external suppressor resistor of a resistance or power rating less than the recommended rating, it is essential that an overload protection device is incorporated in the resistor circuit (refer to Figure 4-14).

**WARNING**

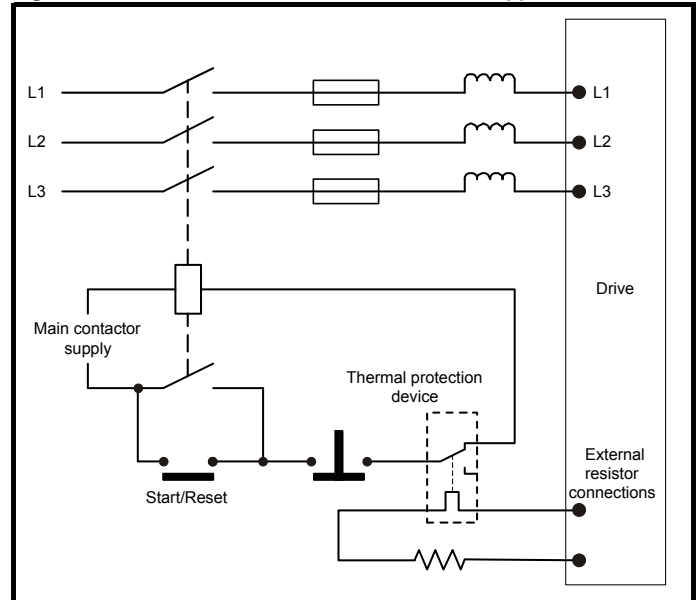


**External suppressor resistor protection parameter settings**

The software provided by the Mentor MP provides overload protection. Failure to correctly configure Pr 11.62, Pr 11.63 and Pr 11.64, as described in the *Mentor MP Advanced User Guide* could lead to the resistor being overloaded.

**WARNING**

**Figure 4-14 Protection circuit for an external suppression resistor**



## 4.8 Ground leakage

The ground leakage current depends on whether an external EMC filter is installed. Ground leakage currents for external EMC filters can be obtained from the manufacturers data sheet for the filter being used.


**With no external EMC filter:**

<1 mA

### 4.8.1 Use of residual current device (RCD)

There are three common types of ELCB / RCD:

1. AC - detects AC fault currents
2. A - detects AC and pulsating DC fault currents (provided the DC current reaches zero at least once every half cycle)
3. B - detects AC, pulsating DC and smooth DC fault currents
  - Type's A and AC should never be used with Mentor MP drives.
  - Type B must be used with all Mentor MP drives.



Only type B ELCB / RCD are suitable for use with Mentor MP drives.

**WARNING**

If an external EMC filter is used, a delay of at least 50 ms should be incorporated to ensure spurious trips are not seen. The leakage current is likely to exceed the trip level if all of the phases are not energized simultaneously.

**NOTE**  
The installer of the drive is responsible for ensuring compliance with the EMC regulations that apply where the drive is to be used.

## 4.9 EMC (Electromagnetic compatibility)

The Mentor MP meets immunity requirements (specified in Table 12-44 *Immunity compliance* on page 179) with no special precautions.

**NOTE**  
Some special measures may be required in certain applications where the control cables are long or pass outside the building. See section 4.9.4 *Surge immunity of control circuits - long cables and connections outside a building* on page 53.

Radio frequency noise emission can occur from any of the power connections i.e. main and auxiliary A.C connections, armature and field output terminals.

For many applications in heavy industrial environments the noise emission is not sufficient to cause interference to other equipment.

When radio frequency emission must be limited the method used should be chosen to suit the situation.

### 4.9.1 Power drive systems standard

Compliance with the EMC standard for power drive systems (PDS) IEC 61800-3, EN 61800-3:2004 category C3

To meet this standard a standard armature filter and a standard field filter must be installed. See Table 4-22 *Mentor MP and EMC filter cross references* on page 53 for EMC filter cross references.

Shielded cables must be used for the field and armature and the shields must be clamped to ground at both ends. The standard is met for cable lengths up to 100 m.

### 4.9.2 Generic standard and PDS category C2

Compliance with the generic emission standards for industrial environments category IEC 61000-6-4 and EN 61000-6-4:2007, and the PDS standard category C2.

To meet this standard a standard field filter and a high performance armature filter must be installed. See Table 4-22 *Mentor MP and EMC filter cross references* on page 53 for EMC filter cross references.

Shielded cables must be used for the field and armature and the shields must be clamped to ground at both ends. The standard is met for cable lengths up to 100 m.



### 4.9.3 EMC filter information

Refer to Figure 4-1 on page 36 for the location of the optional EMC filter. See Table 4-22 for EMC filters that can be sourced directly from Epcos and Schaffner.



It is essential that line reactors be connected between the filter terminals and the power input terminals, as shown in Figure 4-1. Failure to observe this requirement could result in destruction of the thyristors.

**CAUTION**

**Table 4-22 Mentor MP and EMC filter cross references**

Model	Manufacturers part number				
	Schaffner armature standard	Schaffner armature high performance	Epcos armature high performance	Schaffner standard field filter	Epcos standard field filter
MP25A4(R)	FN3270H-80-35	FN3258-75-52	B84143-A66-R105	FN3280H-8-29	W62400-T1262D004
MP45A4(R)			*B84143-A90-R105		
MP75A4(R)					
MP105A4(R)	FN3270H-200-99	FN3258H-180-40	B84143BO250S080	FN3280H-25-33	
MP155A4(R)					
MP210A4(R)					
MP350A4(R)		FN3359-800-99		FN3280H-25-33	
MP420A4(R)					
MP550A4(R)					
MP700A4(R)					
MP825A4(R)					
MP900A4(R)					
MP1200A4(R)					
MP1850A4(R)					
		FN3359-1600-99			

\* This filter is required if the input current to the Mentor MP will be greater than 66 Amperes.

**Table 4-23 Emission compliance**

Model	Filter		
	None	Field: Standard Armature: Standard	Field: Standard Armature: High performance
MP25A4(R)	C4	C3	C2
MP45A4(R)			
MP75A4(R)			
MP105A4(R)			
MP155A4(R)			
MP210A4(R)			
MP350A4(R)			
MP420A4(R)			
MP550A4(R)			
MP700A4(R)			
MP825A4(R)			
MP900A4(R)			
MP1200A4(R)			
MP1850A4(R)			

**Key** (shown in decreasing order of permitted emission level):

- C4 EN 61800-3:2004 second environment, restricted distribution (Additional measures may be required to prevent interference)
- C3 EN 61800-3:2004 second environment, unrestricted distribution
- C2 Industrial generic standard EN 61000-6-4:2007  
EN 61800-3:2004 first environment restricted distribution (The following caution is required by EN 61800-3:2004)

C1 Residential generic standard EN 61000-6-3:2007  
EN 61800-3:2004 first environment unrestricted distribution  
EN 61800-3:2004 defines the following:

- The first environment is one that includes residential premises. It also includes establishments directly connected without intermediate transformers to a low-voltage power supply network which supplies buildings used for residential purposes.
- The second environment is one that includes all establishments other than those directly connected to a low-voltage power supply network which supplies buildings used for residential purposes.
- Restricted distribution is defined as a mode of sales distribution in which the manufacturer restricts the supply of equipment to suppliers, customers or users who separately or jointly have technical competence in the EMC requirements of the application of drives.

### 4.9.4 Surge immunity of control circuits - long cables and connections outside a building

The input/output ports for the control circuits are designed for general use within machines and small systems without any special precautions. In applications where they may be exposed to high-energy voltage surges, some special measures may be required to prevent malfunction or damage. Surges may be caused by lightning or severe power faults in association with grounding arrangements which permit high transient voltages between nominally grounded points. This is a particular risk where the circuits extend outside the protection of a building.



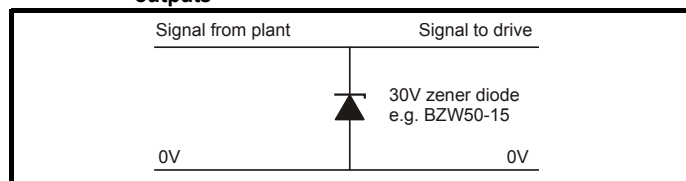
This is a product of the restricted distribution class according to IEC 61800-3. In a residential environment this product may cause radio interference in which case the user may be required to take adequate measures.

**CAUTION**

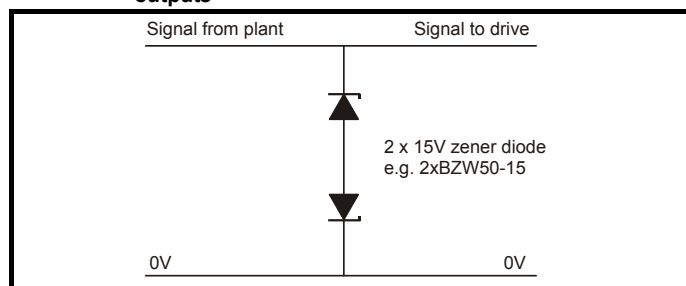
As a general rule, if the circuits are to pass outside the building where the drive is located, or if cable runs within a building exceed 30 m, some additional precautions are advisable. One of the following techniques should be used:

- Galvanic isolation, i.e. do not connect the control 0 V terminal to ground. Avoid loops in the control wiring, i.e. ensure every control wire is accompanied by its return (0 V) wire.
- Shielded cable with additional power ground bonding. The cable shield may be connected to ground at both ends, but in addition the ground conductors at both ends of the cable must be bonded together by a power ground cable (equipotential bonding cable) with cross-sectional area of at least 10 mm<sup>2</sup>, or 10 times the area of the signal cable shield, or to suit the electrical safety requirements of the plant. This ensures that fault or surge current passes mainly through the ground cable and not in the signal cable shield. If the building or plant has a well-designed common bonded network this precaution is not necessary.
- Additional over-voltage suppression - for the analog and digital inputs and outputs, a zener diode network or a commercially available surge suppressor may be connected in parallel with the input circuit as shown in Figure 4-15 and Figure 4-16.

**Figure 4-15 Surge suppression for digital and unipolar inputs and outputs**



**Figure 4-16 Surge suppression for analog and bipolar inputs and outputs**



Surge suppression devices are available as rail-mounting modules, e.g. from Phoenix Contact:

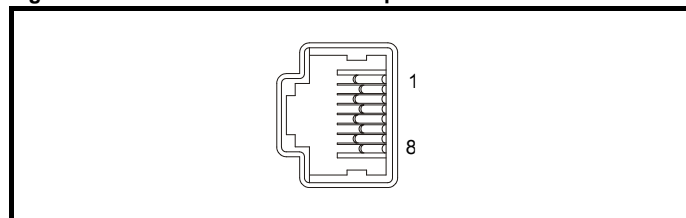
- Unipolar TT-UKK5-D/24 DC
- Bipolar TT-UKK5-D/24 AC

These devices are not suitable for encoder signals or fast digital data networks because the capacitance of the diodes adversely affects the signal. Most encoders have galvanic isolation of the signal circuit from the motor frame, in which case no precautions are required. For data networks, follow the specific recommendations for the particular network.

## 4.10 Serial communications connections

The Mentor MP has a serial communications port (serial port) as standard supporting two wire EIA(RS)-485 communications. See Table 4-24 for the connection details for the RJ45 connector.

**Figure 4-17 Serial communications port**



**Table 4-24 RJ45 connections**

Pin	Function
1	120 Ω Termination resistor
2	RX TX
3	0 V isolated
4	+24 V (100 mA)
5	0 V isolated
6	TX enable
7	RX\ TX\
8	RX\ TX\ (if termination resistors are required, jumper (link) to pin 1)
Shell	0 V isolated

The communications port applies a two-unit load to the communications network. Connectors 2, 3, 7 and shield must always be made to the serial communications port. Shielded cable must be used at all times.

### 4.10.1 Isolation of the serial communications port

The serial PC communications port is double insulated and meets the requirements for SELV in EN 50178:1998.

In order to meet the requirements for SELV in IEC 60950 (IT equipment) it is necessary for the control computer to be grounded. Alternatively, when a lap-top or similar device is used which has no provision for grounding, an isolation device must be incorporated in the communications lead.

**WARNING**

An isolated serial communications lead has been designed to connect the drive to IT equipment (such as laptop computers), and is available from the supplier of the drive. See Table 4-25 for details.

**Table 4-25 Isolated serial comms lead details**

Part number	Description
4500-0087	CT EIA232 Comms cable
4500-0096	CT USB Comms cable

The "isolated serial communications" lead has reinforced insulation as defined in IEC 60950 for altitudes up to 3,000 m.

#### NOTE

When using the CT EIA232 Comms cable the available baud rate is limited to 19.2 k baud.

### 4.10.2 Multi-drop network

The drive can be used on a 2 wire EIA485 multi-drop network using the drive's serial communications port when the following guidelines are adhered to.

#### Connections

The network should be a daisy chain arrangement and not a star, although short stubs to the drive are allowed.

The minimum connections are pins 2 (RX TX), 3 (isolated 0 V), 7 (RX\ TX\ ) and the shield.

Pin 4 (+24 V) on each drive can be connected together but there is no power sharing mechanism between drives and therefore the maximum power available is the same as a single drive. (If pin 4 is not linked to the other drives on the network and has an individual load then the maximum power can be taken from pin 4 of each drive.)

#### Termination resistors

If a drive is on the end of the network chain then pins 1 and 8 should be linked together. This will connect an internal 120 Ω termination resistor between RXTX and RX\TX\ . (If the end unit is not a drive or the user wishes to use their own termination resistor, a 120 Ω termination resistor should be connected between RXTX and RX\TX\ at the end unit.)

If the host is connected to a single drive then termination resistors should not be used unless the baud rate is high.

## CT Comms cable

The CT Comms cable can be used on a multi-drop network but should only be used occasionally for diagnostic and set up purposes. The network must also be made up entirely of Mentor MPs.

If the CT Comms cable is to be used, then pin 6 (TX enable) should be connected on all drives and pin 4 (+24 V) should be linked to at least one drive in order to supply power to the converter in the cable. Only one CT Comms cable can be used on a network.

### 4.11 Shield connections

These instructions must be followed to ensure suppression of radio-frequency emission and good noise immunity in the encoder circuit. It is recommended that the instructions for the connection of the encoder cable be followed closely and, to use the grounding bracket and grounding clamp supplied with the drive, to terminate the shields at the drive.

#### 4.11.1 Motor cables

Use of a motor cable with an overall shield for the armature and field circuits may be needed if there is a critical EMC emissions requirement. Connect the shield of the motor cable to the ground terminal of the motor frame using a jumper (link) that is as short as possible and not exceeding 50 mm (2 in) long. A full 360° termination of the shield to the terminal housing of the motor is beneficial.

#### 4.11.2 Encoder cable

To obtain the maximum benefit from shielding, use cable with an overall shield and separate shields on individual twisted pairs. Refer to section 4.15 *Connecting an encoder* on page 60.

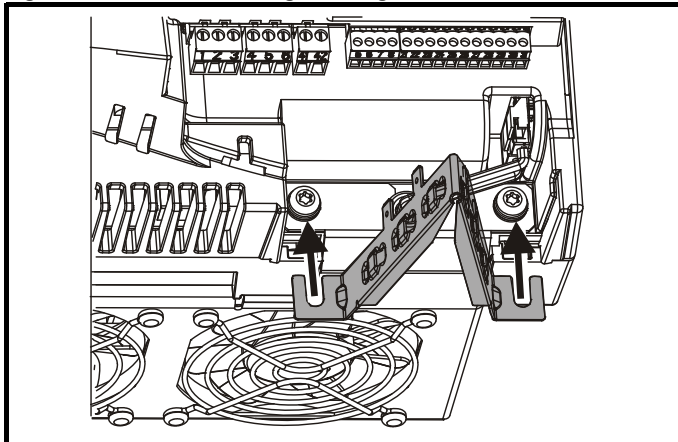
#### 4.11.3 Control cables

It is recommended that signal cables should be shielded. This is essential for encoder cables, and strongly recommended for analog signal cables. For digital signals it is not necessary to use shielded cables within a panel, but this is recommended for external circuits, especially for inputs where a momentary signal causes a change of state (i.e. latching inputs).

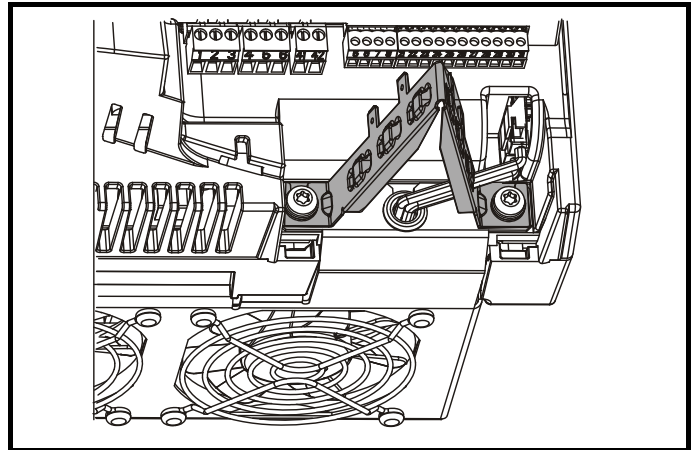
#### 4.11.4 Grounding hardware

The drive is supplied with a grounding bracket, to facilitate EMC compliance. This provides a convenient method for direct grounding of cable shields without the use of "pig-tails". Cable shields can be bared and clamped to the grounding bracket using metal clips, clamps or cable ties. Note that the shield must in all cases be continued through the clamp to the intended drive terminal in accordance with the connection details for the specific signal.

**Figure 4-18 Installation of grounding bracket**

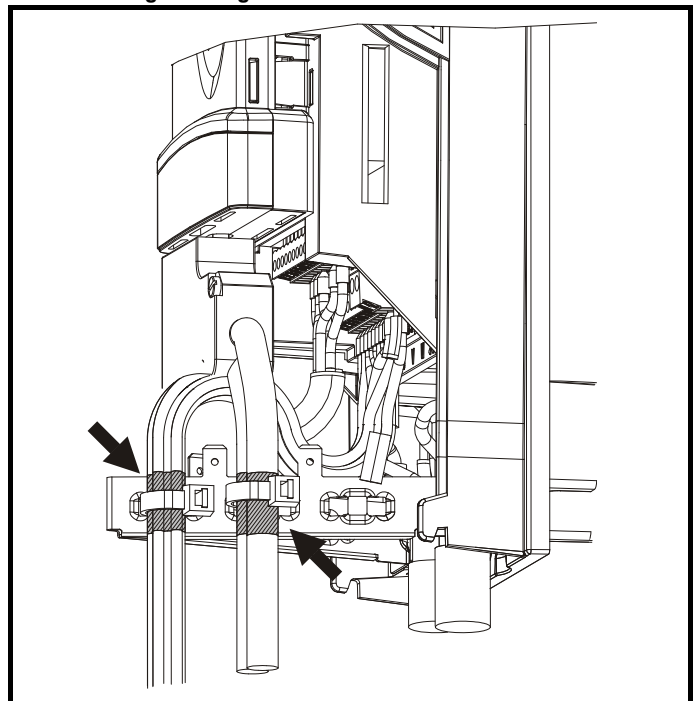


Loosen the ground connection (2 x M5 x 10) screws using T25 Torx driver and slide the grounding bracket in the direction shown. Once in place, re-tighten the ground connection M5 x 10 screws to 3 N m (2.21 lb ft).



A faston tab is located on the grounding bracket for the purpose of connecting the drive 0 V to ground should the user wish to do so.

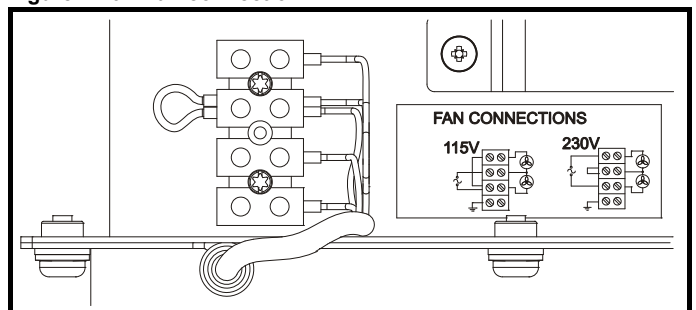
**Figure 4-19 Grounding of signal cable shields using the grounding bracket**



### 4.12 Connecting the fan on size 2C and 2D drives

A supply needs to be connected to the dual fan unit enclosed within the lower duct on Mentor MP size 2C and 2D. The fans can be configured for a 230 Vac (factory setting) or 115 Vac supply as shown below on the label next to the fan connections. When connecting the fan supply, the screws should be tightened with a maximum torque of 1.2 N m (0.88 lb ft) to 2 N m (1.47 lb ft).

**Figure 4-20 Fan connection**



**Table 4-26 Fan supply specification**

Fan configuration	Supply specification
230 V	230 V ± 10 %
115 V	115 V ± 10 %

Cabling should be 300 V rated. Rated for at least 3 A continuous in line with local wiring regulations. Cabling should be protected 3 A non time delay fuses i.e. gG, Class CC or Class J and rated for at least 300 V, in accordance with local wiring regulations.

## 4.13 Control connections

Refer to Figure 4-21 to understand the connection of the different control connections.

### 4.13.1 General

**Table 4-27 The control connections consist of:**

Function	Qty	Control parameters available	Terminal number
Differential analog input	1	Destination, offset, invert, scaling	5,6
Single ended analog input	2	Mode, offset, scaling, invert, destination	7,8
Analog output	2	Source, mode, scaling,	9,10
Digital input	3	Destination, invert, logic select	27, 28, 29
Digital input / output	3	Input / output mode select, destination / source, invert, logic select	24, 25, 26
Relay	2	Source, invert	51, 52, 53 61, 62, 63
Drive enable	1	Logic select	31
+10 V User output	1		4
+24 V User output	1		22
0 V common	6		1, 3, 11, 21, 23, 30
+24 V External input	1		2

**Key:**

**Destination parameter:** Indicates the parameter which is being controlled by the terminal / function

**Source parameter:** Indicates the parameter being output by the terminal

**Mode parameter:** Analog - indicates the mode of operation of the terminal, i.e. voltage 0-10 V, current 4-20 mA etc.

Digital - indicates the mode of operation of the terminal, i.e. positive / negative logic, open collector.

All analog terminal functions can be programmed in menu 7.

All digital terminal functions (including the relays) can be programmed in menu 8.

The setting of Pr **6.04** can cause the function of digital inputs T25 to T27 to change. For more information, refer to the *Mentor MP Advanced User Guide*.



If the control circuits are to be connected to other circuits classified as Safety Extra Low Voltage (SELV) (e.g. to a personal computer), an additional isolating barrier must be included in order to maintain the SELV classification.



If any of the digital inputs (including the drive enable input) are connected in parallel with an inductive load (i.e. contactor or motor brake) then suitable suppression (i.e. diode or varistor) should be used on the coil of the load. If no suppression is used then over voltage spikes can cause damage to the digital inputs on the drive.



The control circuits are isolated from the power circuits in the drive by basic insulation (single insulation) only. The installer must ensure that the external control circuits are insulated from human contact by at least one layer of insulation (supplementary insulation) rated for use at the AC supply voltage.



Status relay contacts are over-voltage category II.

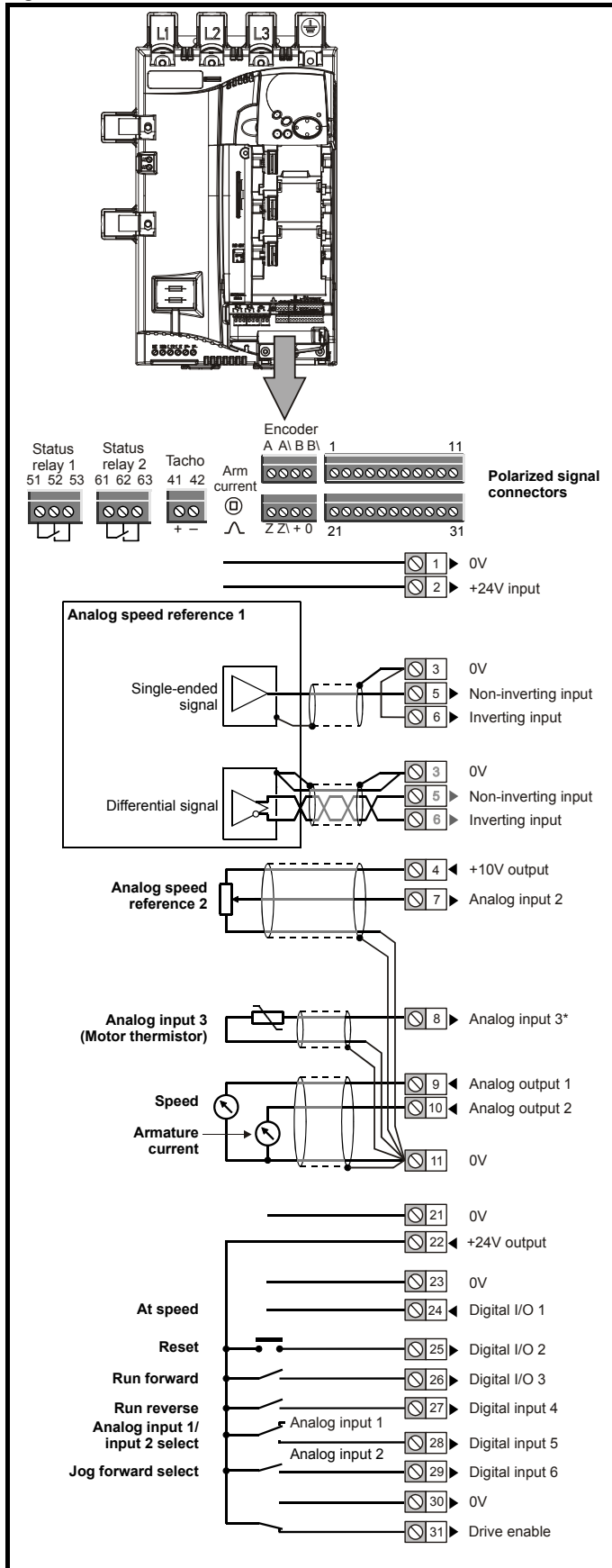


A fuse or other over-current protection should be installed to the relay circuit.

**Table 4-28 Control connection recommended cable sizes**

Terminal	Minimum cable size	Maximum cable size
Machine armature	0.5 mm <sup>2</sup> 20 AWG	5 mm <sup>2</sup> 10 AWG
Auxiliary		1.31 mm <sup>2</sup> 16 AWG
Control I/O		
Encoder		
Tachogenerator		2.5 mm <sup>2</sup> 12 AWG
Status relays		

Figure 4-21 Default terminal functions



\* Thermistor disabled by USA defaults.

## 4.14 General

### 4.14.1 Control terminal specification

<b>1</b>	<b>0 V common</b>
<b>Function</b>	<b>Common connection for all external devices</b>

<b>2</b>	<b>+24 V external input</b>
<b>Function</b>	<b>To supply the control circuit without providing a supply to the power stage</b>
Nominal voltage	+24.0 Vdc
Minimum continuous operating voltage	+19.2 Vdc
Maximum continuous operating voltage	+30.0 Vdc
Minimum start-up voltage	21.6 Vdc
Recommended power supply	60 W 24 Vdc nominal
Recommended fuse	3 A, 50 Vdc

<b>3</b>	<b>0 V common</b>
<b>Function</b>	<b>Common connection for all external devices</b>

<b>4</b>	<b>+10 V user output</b>
<b>Function</b>	<b>Supply for external analog devices</b>
Voltage tolerance	±1 %
Nominal output current	10 mA
Protection	Current limit and trip @12 mA

<b>5</b>	<b>Precision reference analog input 1</b>
<b>6</b>	<b>Non-inverting input</b>
<b>6</b>	<b>Inverting input</b>
<b>Default function</b>	<b>Speed reference</b>
Type of input	Bipolar differential analog (For single-ended use, connect terminal 6 to terminal 3)
Full scale voltage range	±10.0 V ±1.5 %
Absolute maximum voltage range	+30 V, -18 V relative to 0 V
Working common mode voltage range	±16 V
Input resistance	94 k Ω
Resolution	14-bit plus sign
Monotonic	Yes
Dead band	None
Jumps	None
Maximum offset	±5 mV
Maximum non linearity	±0.05 % of Full scale voltage range
Maximum gain asymmetry	±0.2 %
Input filter bandwidth single pole	~1 kHz
Sampling period	250 μs if configured with the destination as Pr 1.36, Pr 1.37, Pr 3.19 and Pr 4.08. 4 ms for all other destinations

7 Analog input 2	
<b>Default function</b>	<b>Speed reference</b>
Type of input	Unipolar voltage and current
Mode controlled by...	Pr 7.11
<b>Operating in Voltage mode</b>	
Full scale voltage range	$\pm 10.0 \text{ V} \pm 0.5 \%$
Maximum offset	$\pm 33 \text{ mV}$
Absolute maximum voltage	$\pm 36 \text{ V}$ relative to 0 V
Input resistance	$>94 \text{ k}\Omega$
<b>Operating in current mode</b>	
Current ranges	0 to 20 mA $\pm 5 \%$ , 20 to 0 mA $\pm 5 \%$ , 4 to 20 mA $\pm 5 \%$ , 20 to 4 mA $\pm 5 \%$
Maximum offset	120 $\mu\text{A}$
Absolute maximum voltage	$\pm 36 \text{ V}$
Equivalent input resistance	$\sim 100 \Omega$
<b>Common to all modes</b>	
Resolution	10 bit plus sign
Sampling period	250 $\mu\text{s}$ if configured with the destination as Pr 1.36, Pr 1.37, Pr 3.19 and Pr 4.08. 4 ms for all other destinations

8 Analog input 3	
<b>Default function</b>	<b>Thermistor</b>
Type of input	Unipolar voltage, unipolar current and thermistor
Input mode controlled by...	Pr 7.15 (in01, 0.81)
<b>Operating in Voltage mode</b>	
Voltage range	$\pm 10.0 \text{ V} \pm 0.5 \%$
Maximum offset	$\pm 33 \text{ mV}$
Absolute maximum voltage range	$\pm 36 \text{ V}$ relative to 0 V
Input resistance	$>94 \text{ k}\Omega$
<b>Operating in current mode</b>	
Current ranges	0 to 20 mA $\pm 5 \%$ , 20 to 0 mA $\pm 5 \%$ , 4 to 20 mA $\pm 5 \%$ , 20 to 4 mA $\pm 5 \%$
Maximum offset	120 $\mu\text{A}$
Absolute maximum voltage	$\pm 36 \text{ V}$ max
Equivalent input resistance	$\sim 100 \Omega$
<b>Operating in thermistor input mode</b>	
Internal pull-up voltage	$<5 \text{ V}$
Trip threshold resistance	$3.3 \text{ k}\Omega \pm 10 \%$
Reset resistance	$1.8 \text{ k}\Omega \pm 10 \%$
Short-circuit detection resistance	$50 \Omega \pm 40 \%$
<b>Common to all modes</b>	
Resolution	10 bit + sign
Sampling period	250 $\mu\text{s}$ if configured with the destination as Pr 1.36, Pr 1.37, Pr 3.19 and Pr 4.08. 4 ms for all other destinations

9 Analog output 1	
10 Analog output 2	
<b>Terminal 9 default function</b>	<b>Speed feedback</b>
<b>Terminal 10 default function</b>	<b>Current feedback</b>
Type of output	Bipolar single-ended voltage or unipolar single-ended current
Mode controlled by...	
<b>Operating in Voltage mode (default)</b>	
Full scale voltage range	$\pm 10 \text{ V} \pm 5 \%$
Maximum offset	$\pm 40 \text{ mV}$
Maximum output current	$\pm 35 \text{ mA}$
Load resistance	1 $\text{k}\Omega$ min
Protection	35 mA max. Short circuit protection
<b>Operating in current mode</b>	
Current ranges	0 to 20 mA $\pm 5 \%$ 4 to 20 mA $\pm 5 \%$
Maximum offset	350 $\mu\text{A}$
Open circuit voltage	+15 V
Load resistance	600 $\Omega$ max
<b>Common to all modes</b>	
Resolution	10-bit plus sign
Sampling period	250 $\mu\text{s}$ if configured with the destination as Pr 1.36, Pr 1.37, Pr 3.19 and Pr 4.08. 4 ms for all other destinations

11 0 V common	
<b>Function</b>	<b>Common connection for all external devices</b>

21 0 V common	
<b>Function</b>	<b>Common connection for all external devices</b>

22 +24 V user output	
<b>Function</b>	<b>Supply for external digital devices</b>
Nominal output current	200 mA (including all digital I/O)
Maximum output current	240 mA (including all digital I/O)
Protection	Current limit and trip

23 0 V common	
<b>Function</b>	<b>Common connection for all external devices</b>




<b>24</b>	<b>Digital I/O 1</b>
<b>25</b>	<b>Digital I/O 2</b>
<b>26</b>	<b>Digital I/O 3</b>
<b>Terminal 24 default function</b>	<b>AT SPEED output</b>
<b>Terminal 25 default function</b>	<b>DRIVE RESET input</b>
<b>Terminal 26 default function</b>	<b>RUN FORWARD input</b>
Type	Positive or negative logic digital inputs, positive or negative logic push-pull outputs or open collector outputs
Input / output mode controlled by...	Pr 8.31, Pr 8.32 and Pr 8.33
<b>Operating as an input</b>	
Logic mode controlled by...	Pr 8.29
Absolute maximum applied voltage range	+30 V, -18 V relative to 0 V
Impedance	6 kΩ
Input thresholds	10.0 V ± 0.8 V
<b>Operating as an output</b>	
Open collector outputs selected	Pr 8.30
Nominal maximum output current	200 mA (total including terminal 22)
Maximum output current	240 mA (total including terminal 22)
<b>Common to all modes</b>	
Voltage range	0 V to +24 V
Sampling period	250 μs if configured with the destination as Pr 6.35 or Pr 6.36. 4 ms for all other destinations

<b>27</b>	<b>Digital input 4</b>
<b>28</b>	<b>Digital input 5</b>
<b>29</b>	<b>Digital input 6</b>
<b>Terminal 27 default function</b>	<b>RUN REVERSE input</b>
<b>Terminal 28 default function</b>	<b>LOCAL/REMOTE select</b>
<b>Terminal 29 default function</b>	<b>JOG SELECT input</b>
Type of input	Negative or positive logic digital inputs
Logic mode controlled by...	Pr 8.29
Voltage range	0 V to +24 V
Absolute maximum applied voltage range	+30 V, -18 V relative to 0 V
Impedance	6 k Ω
Input thresholds	10.0 V ± 0.8 V
Sampling period	250 μs if configured with the destination as Pr 6.35 or Pr 6.36. 4 ms for all other destinations

<b>30</b>	<b>0 V common</b>
<b>Function</b>	<b>Common connection for all external devices</b>

<b>31</b>	<b>Drive enable</b>
<b>Function</b>	<b>Drive enable</b>
Type	Positive or negative logic digital input
Absolute maximum applied voltage range	+30 V, -18 V relative to 0 V
Input threshold	10.0 V ± 0.8 V
Sampling period	4 ms

 <b>Drive commissioning output</b>	
<b>Function</b>	<b>Instantaneous armature current feedback</b>
Type of output	Unipolar single-ended voltage
Full scale voltage range	10 V ± 5 % (10 V = 2 x Motor rated current)
Maximum offset	7 mV
Protection	~25 mA max. Short circuit protection to ground (0 V).

Model			Full scale range of drive commissioning output
MP25A4(R)	MP25A5(R)		2.29 x Drive rated current (Pr 11.32)
MP45A4(R)	MP45A5(R)		2.30 x Drive rated current (Pr 11.32)
MP75A4(R)	MP75A5(R)		2.42 x Drive rated current (Pr 11.32)
MP105A4(R)	MP105A5(R)		2.29 x Drive rated current (Pr 11.32)
MP155A4(R)	MP155A5(R)		2.30 x Drive rated current (Pr 11.32)
MP210A4(R)	MP210A5(R)		2.41 x Drive rated current (Pr 11.32)
MP350A4(R)	MP350A5(R)	MP350A6(R)	2.73 x Drive rated current (Pr 11.32)
MP420A4(R)			2.27 x Drive rated current (Pr 11.32)
	MP470A5(R)	MP470A6(R)	3.34 x Drive rated current (Pr 11.32)
MP550A4(R)			2.85 x Drive rated current (Pr 11.32)
MP700A4(R)	MP700A5(R)	MP700A6(R)	2.24 x Drive rated current (Pr 11.32)
MP825A4(R)	MP825A5(R)	MP825A6(R)	2.46 x Drive rated current (Pr 11.32)
MP900A4(R)			2.25 x Drive rated current (Pr 11.32)
MP1200A4(R)	MP1200A5(R)	MP1200A6(R)	3.44 x Drive rated current (Pr 11.32)
MP1850A4(R)	MP1850A5(R)	MP1850A6(R)	2.23 x Drive rated current (Pr 11.32)

<b>41</b>	<b>Tachogenerator positive input</b>
<b>42</b>	<b>Tachogenerator negative input</b>
<b>Function</b>	<b>Speed feedback inputs for tachogenerator feedback device</b>
Maximum voltage	300 V
Feedback scaling controlled by	Pr 3.51 (Fb02, 0.72)
Sampling period	4 ms



Status relay contacts are over-voltage category II.

**WARNING**



A fuse or other over-current protection should be installed to the relay circuit.

**WARNING**

<b>51</b>	<b>Relay 1 common</b>
<b>52</b>	<b>Relay 1 normally closed</b>
<b>53</b>	<b>Relay 1 normally open</b>
<b>Default function</b>	
<b>Drive OK indicator</b>	
Contact voltage rating	240 Vac, installation over-voltage category II
Contact maximum current rating	5 A AC 240 V 5 A DC 30 V resistive load 0.5 A DC 30 V inductive load (L/R = 40 ms)
Contact minimum recommended rating	12 V, 100 mA
Default contact position	Closed when power on and drive OK
Sampling period	4 ms

<b>61</b>	<b>Relay 2 common</b>
<b>62</b>	<b>Relay 2 normally closed</b>
<b>63</b>	<b>Relay 2 normally open</b>
<b>Default function</b>	
<b>Contactor enable</b>	
Contact voltage rating	240 Vac, installation over-voltage category II
Contact maximum current rating	5 A AC 240 V 5 A DC 30 V resistive load 0.5 A DC 30 V inductive load (L/R = 40 ms)
Contact minimum recommended rating	12 V, 100 mA
Default contact position	Closed when AC or DC contactor is required to be closed.
Sampling period	4 ms

**NOTE**

The relays are not UL rated when used with inductive loads.

**Feedback device connections**

**Ab, Fd, Fr encoders**

<b>A</b>	<b>Channel A, Frequency or Forward inputs</b>
<b>A\</b>	<b>Channel A\, Frequency\ or Forward\ inputs</b>
<b>B</b>	<b>Channel B, Direction or Reverse inputs</b>
<b>B\</b>	<b>Channel B\, Direction\ or Reverse\ inputs</b>
<b>Z</b>	<b>Marker pulse channel Z</b>
<b>Z\</b>	<b>Marker pulse channel Z\</b>
Type	EIA 485 differential receivers
Maximum input frequency	500 kHz
Line loading	<2 unit loads
Line termination components	100 Ω for 2 - 5 V range (switchable)
Working common mode range	+12 V to -7 V
Absolute maximum applied voltage relative to 0 V	± 25 V
Absolute maximum applied differential voltage	± 25 V

<b>+</b>	<b>+ supply</b>
<b>0V</b>	<b>0 V</b>

## 4.15 Connecting an encoder

Additional measures to prevent unwanted emission of radio frequency noise are only required where the installation is subject to specific requirements for radio frequency emission.

**Encoder connections:**

To ensure suppression of radio frequency emission, observe the following:

- Use an encoder with the correct impedance
- Use a cable with individually shielded twisted pairs.
- Connect the cable shields to 0 V at both the drive and the encoder, using the shortest possible links (pig-tails).
- The cable should not be interrupted. If interruptions are unavoidable, ensure the absolute minimum length of "pig-tail" in the shield connections at each interruption. Use a connection method that provides substantial metallic clamps for the cable shield terminations.

The above applies where the encoder body is isolated from the motor and where the encoder circuit is isolated from the encoder body. Where there is no isolation between the encoder circuits and motor body, and in case of doubt, the following additional requirements must be observed to give the best possible noise immunity.

- The shields must be directly clamped to the encoder and to the drives grounding bracket. This may be achieved by clamping of the individual shields or by providing an additional overall shield that is clamped.

**NOTE**

The recommendations of the encoder manufacturer should also be adhered to for the encoder connections.

**NOTE**

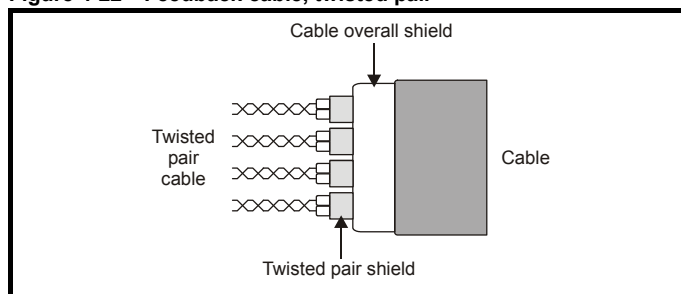
In order to obtain maximum noise immunity for any application, double shielded cable should be used as shown.

In some cases single shielding of each pair of differential signals cables, or a single overall shield with individual shield on the thermistor connections is sufficient. In these cases all the shields should be connected to ground and 0 V at both ends.

If the 0 V is required to be left floating a cable with individual shields and an overall shield must be used.

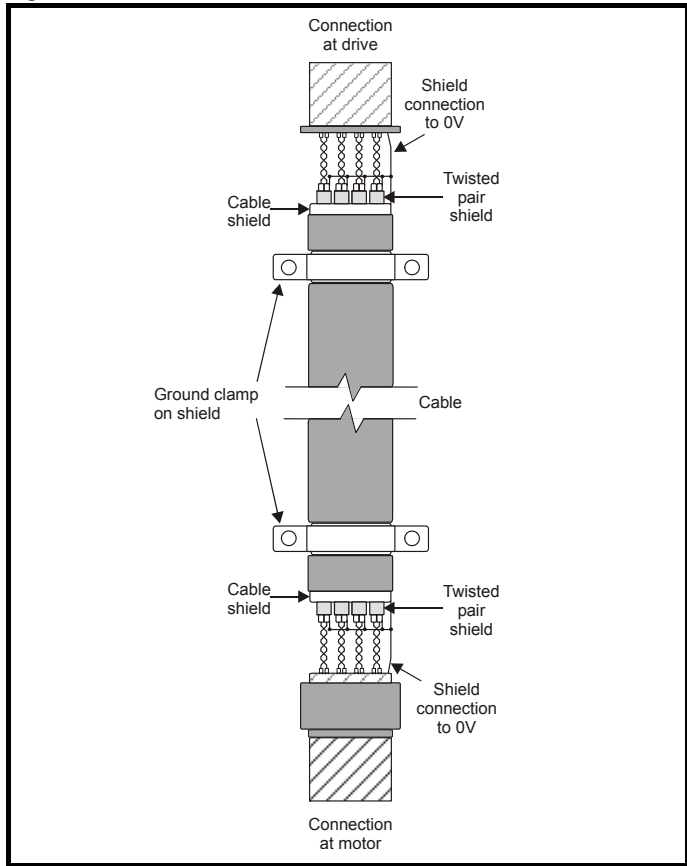
Figure 4-22 and Figure 4-23 illustrate the preferred construction of cable and the method of clamping. The outer sheath of the cable should be stripped back enough to allow the clamp to be installed. The shield must not be broken or opened at this point. The clamps should be installed close to the drive or feedback device, with the ground connections made to a ground plate or similar metallic ground surface.

**Figure 4-22 Feedback cable, twisted pair**





**Figure 4-23 Feedback cable connections**



**Table 4-29 Encoder types**

<b>Pr 3.38 (Fb07, 0.77) setting</b>	<b>Description</b>
<b>Ab (0)</b>	Quadrature incremental encoder with or without marker pulse
<b>Fd (1)</b>	Incremental encoder with frequency pulses and direction, with or without marker pulse
<b>Fr (2)</b>	Incremental encoder with forward pulses and reverse pulses, with or without marker pulse

## 5 Getting started

This chapter introduces the user interfaces, menu structure and security level of the drive.

### 5.1 Understanding the display

There are two types of keypad available for the Mentor MP. The SM-Keypad has an LED display, and the MP-Keypad has an LCD display.

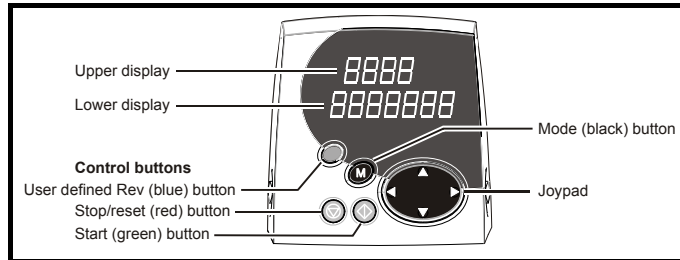
#### 5.1.1 SM-Keypad (LED)

The display consists of two horizontal rows of 7 segment LED displays.

The upper display shows the drive status or the current menu and parameter number being viewed.

The lower display shows the parameter value or the specific trip type.

Figure 5-1 SM-Keypad



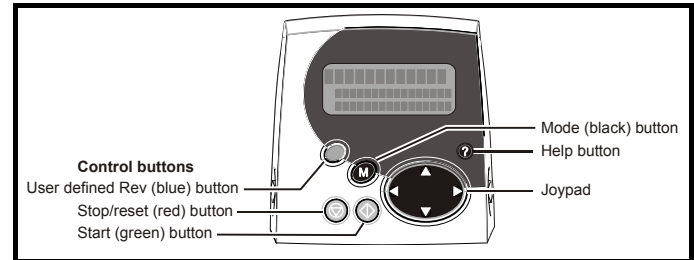
#### 5.1.2 MP-Keypad (LCD)

The display consists of three lines of text.

The top line shows the drive status or the current menu and parameter number being viewed on the left, and the parameter value or the specific trip type on the right.

The lower two lines show the parameter name or the help text.

Figure 5-2 MP-Keypad



#### NOTE

The red stop button is also used to reset the drive.

The SM-Keypad and the MP-Keypad can indicate when a SMARTCARD access is taking place or when the second motor map is active (menu 21). These are indicated on the displays as follows.

	SM-Keypad	MP-Keypad
SMARTCARD access taking place	The decimal point after the fourth digit in the upper display will flash.	The symbol 'CC' will appear in the lower left hand corner of the display
Second motor map active	The decimal point after the third digit in the upper display will flash.	The symbol 'Mot2' will appear in the lower left hand corner of the display
Solutions Module parameters displayed		The symbol 'Opx' will appear in the left hand corner of the display

### 5.2 Keypad operation

Control buttons

The keypad consists of:

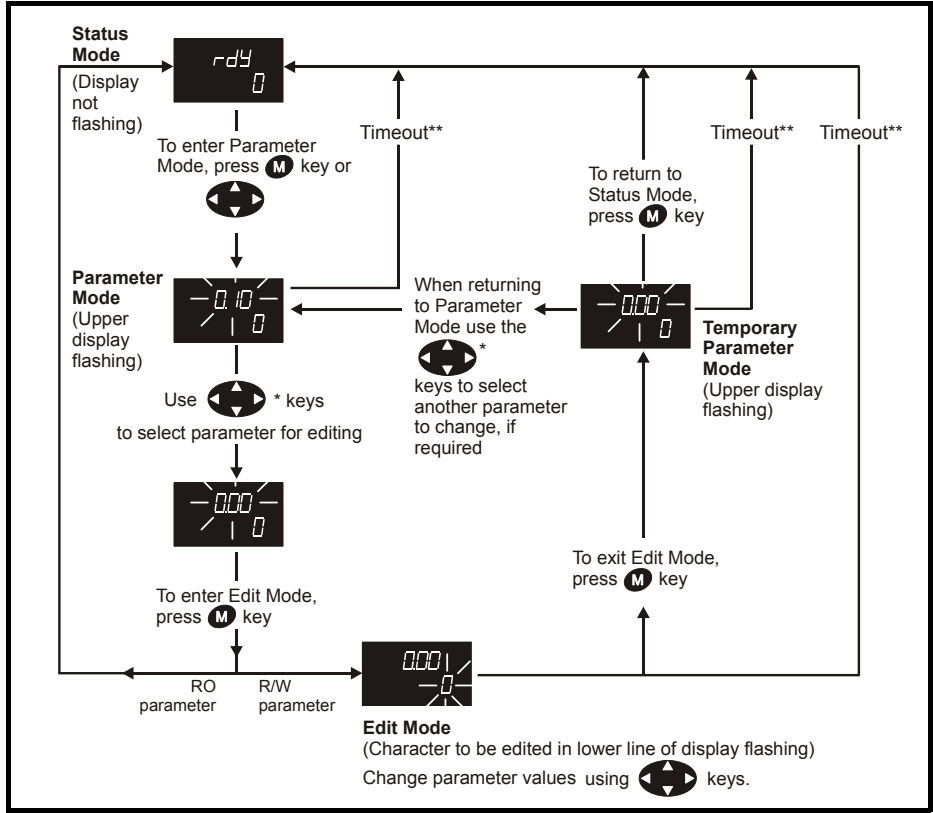
1. Joypad - used to navigate the parameter structure and change parameter values.
2. Mode button - used to change between the display modes – parameter view, parameter edit, status.
3. Three control buttons - used to control the drive if keypad mode is selected.
4. Help button (MP-Keypad only) - displays text briefly describing the selected parameter.

The Help button toggles between other display modes and parameter help mode. The up and down functions on the joypad scroll the help text to allow the whole string to be viewed. The right and left functions on the joypad have no function when help text is being viewed.

The display examples in this section show the SM-Keypad, seven segment, LED display. The examples are the same for the MP-Keypad, The exceptions is that the information displayed on the lower row on the SM-Keypad is displayed on the right hand side of the top row on the MP-Keypad.

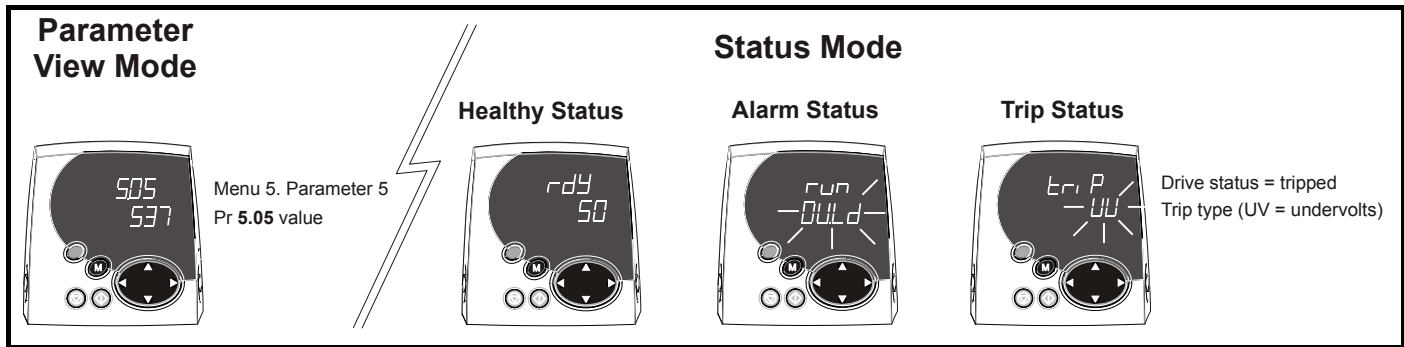
The display examples in this section show the SM-Keypad 7 segment LED display. The examples are the same for the MP-Keypad except that the information displayed on the lower row on the SM-Keypad is displayed on the right hand side of the top row on the MP-Keypad.

**Figure 5-3 Display modes**



\* Can only be used to move between menus if L2 access has been enabled Pr 11.44 (SE14, 0.35)  
 \*\*Time-out defined by Pr 11.41 (default value = 240 s).

**Figure 5-4 Mode examples**



**WARNING** Do not change parameter values without careful consideration; incorrect values may cause damage or a safety hazard.

**NOTE** When changing the values of parameters, make a note of the new values in case they need to be entered again.

**NOTE** For new parameter-values to apply after the AC supply to the drive is interrupted, new values must be saved (section 5.8 Saving parameters on page 67).

### 5.3 Menu 0 (sub block)

Menu 0 can be accessed by 2 methods:

1. Pr 11.44 (SE14, 0.35) = 0. Sub block mode.
2. Pr 11.44 (SE14, 0.35) <>0. Linear mode.

Menu 23 contains the parameters to allow menu 0 to be customized in sub block mode. The first sub block is a user defined area (USER) which is configured by the parameters in menu 22. As default there are no parameters configured to the user sub block and so it is empty. The next 7 sub blocks are pre-defined. Access to the pre-defined blocks is enabled or disabled by Pr 23.03 to Pr 23.09.

Movement between sub blocks is achieved with the left and right keys.

Pr 23.01 contains all the sub block headers.

Table 5-1 and Figure 5-5 show the result of the direction keys when Pr 11.44 (SE14, 0.35) is set to L1 (0). When Pr 11.44 (SE14, 0.35) is not 0 the left and right keys will allow access to the advance parameter set and menu 0 will become a linear menu.

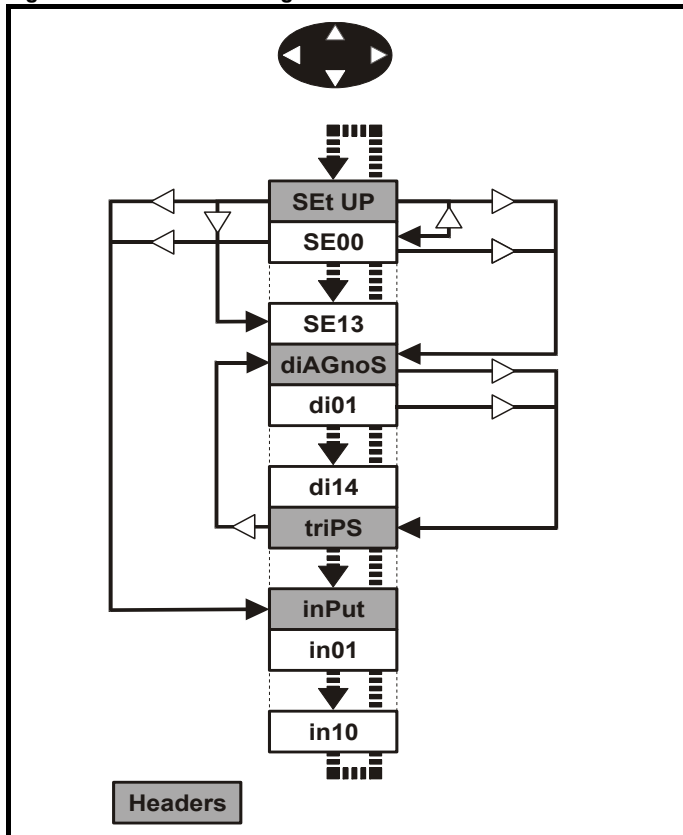
**Table 5-1 Keypad navigation**

Starting location	Action	Finishing location
Header	Right	Next header
	Left	Previous header
	Up	First parameter in header block
	Down	Last parameter in header block
Parameter	Right	Next header
	Left	Previous header
	Up	Next parameter in header block
	Down	Previous parameter in header block

When moving to the user block header, the user block header is only displayed if there are some valid parameters in the block. When moving between pre-defined header blocks the pre-defined header block is only displayed if the pre-defined block is enabled.

When moving between parameters within a block, only valid parameters are displayed.

**Figure 5-5 Sub block navigation**



### Coding

The coding defines the attributes of the parameter as follows.

Coding	Attribute
{X.XX}	Copied Menu 0 or advanced parameter
Bit	1 bit parameter: 'On' or 'OFF' on the display
Bi	Bipolar parameter
Uni	Unipolar parameter
Txt	Text: the parameter uses text strings instead of numbers.
SP	Spare: not used
FI	Filtered: some parameters which can have rapidly changing values are filtered when displayed on the drive keypad for easy viewing.
DE	Destination pointer parameter: This parameter can be used to set up the location (i.e. menu/parameter number) where the destination data is to be routed.
VM	Variable maximum: the maximum of this parameter can vary.
DP	Decimal place: indicates the number of decimal places used by this parameter.
ND	No default: when defaults are loaded (except when the drive is manufactured or on EEPROM failure) this parameter is not modified.
RA	Rating dependant: this parameter is likely to have different values and ranges with drives of different voltage and current ratings. Parameters with this attribute will not be transferred to the destination drive by a SMARTCARD when the rating of the destination drive is different from the source drive if the drive voltage ratings are different or the file is a parameter file. However, the value will be transferred if only the current rating is different and the file is a differences from default type file.
NC	Not copied: not transferred to or from SMARTCARD during copying.
NV	Not visible: not visible on the keypad.
PT	Protected: cannot be used as a destination.
US	User save: saved in drive EEPROM when the user initiates a parameter save.
RW	Read/write: can be written by the user.
RO	Read only: can only be read by the user
BU	Bit default one/unsigned: Bit parameters with this flag set to one have a default of one (all other bit parameters have a default of zero. Non-bit parameters are unipolar if this flag is one.
PS	Power-down save: parameter automatically saved in drive EEPROM when the under volts (UV) trip occurs. Power-down save parameters are also saved in the drive when the user initiates a parameter save.

23.01		Sub block headers	
RO	Txt	NC	BU
↕	USER (0), SEt UP (1), diAGnoS (2), triPS (3), SP LOOP (4), SintEr (5), Fb SP (6), inPut (7)		⇒ USER (0)

Defines the sub block headers. Can be used by the MP-Keypad to display the same strings as the SM-Keypad.

<b>23.02</b>	<b>Binary sum of pre-defined sub block enables</b>										
RO		NC						PT		BU	
↕	0 to 127						⇒	0			

The OR of Pr 23.03 to Pr 23.09. To be used by the MP-Keypad.

Parameter	Value
23.03	1
23.04	2
23.05	4
23.06	8
23.07	16
23.08	32
23.09	64

<b>23.03 - 23.09</b>	<b>Pre-defined sub block enable</b>										
RW	Bit								US	BU	
↕	0 to 1						⇒	1			

When this parameter is set to 1 the associated pre-defined sub block is accessible. When this parameter is 0 the associated pre-defined block is bypassed.

Parameter	Description	Display
23.03	Set up	SEt UP
23.04	Diagnostic	diAGnoS
23.05	Trips	triPS
23.06	Speed loop	SP LOOP
23.07	Serial interface	SintEr
23.08	Speed feedback	Fb SP
23.09	IO	InPut

## 5.4 Pre-defined sub blocks

Menu 0	Parameter	Description	Display
0.01 to 0.20		Configured by Pr 22.01 to Pr 22.20	

### Set-up

Menu 0	Parameter	Description	Display
0.21	1.00	Parameter 0	SE00
0.22	1.07	Minimum reference clamp	SE01
0.23	1.06	Maximum reference clamp	SE02
0.24	2.11	Acceleration rate	SE03
0.25	2.21	Deceleration rate	SE04
0.26	1.14	Reference selector	SE05
0.27	5.09	Armature rated voltage	SE06
0.28	5.07	Motor rated current	SE07
0.29	5.08	Base speed	SE08
0.30	11.42	Parameter copying	SE09
0.31	5.70	Rated field current	SE10
0.32	5.73	Rated field voltage	SE11
0.33	5.77	Enable field control	SE12
0.34	5.12	Autotune	SE13
0.35	11.44	Security status	SE14

## Diagnostic

Menu 0	Parameter	Description	Display
0.36	1.01	Speed reference selected	di01
0.37	1.03	Pre-ramp reference	di02
0.38	2.01	Post ramp reference	di03
0.39	3.01	Final speed reference	di04
0.40	3.02	Speed feedback	di05
0.41	3.04	Speed controller output	di06
0.42	4.03	Torque demand	di07
0.43	4.01	Current magnitude	di08
0.44	5.56	Field current feedback	di09
0.45	5.02	Armature voltage	di10
0.46	1.11	Reference enabled indicator	di11
0.47	1.12	Reverse selected indicator	di12
0.48	1.13	Jog selected indicator	di13
0.49	11.29	Software version	di14
0.50	0.00	Spare	

## Trips

Menu 0	Parameter	Description	Display
0.51	10.20	Trip 0	tr01
0.52	10.21	Trip 1	tr02
0.53	10.22	Trip 2	tr03
0.54	10.23	Trip 3	tr04
0.55	10.24	Trip 4	tr05
0.56	10.25	Trip 5	tr06
0.57	10.26	Trip 6	tr07
0.58	10.27	Trip 7	tr08
0.59	10.28	Trip 8	tr09
0.60	10.29	Trip 9	tr10

## Speed loop

Menu 0	Parameter	Description	Display
0.61	3.10	Speed controller proportional gain	SP01
0.62	3.11	Speed controller integral gain	SP02
0.63	3.12	Speed controller differential feedback gain	SP03
0.64	0.00	Spare	
0.65	0.00	Spare	

## Serial interface

Menu 0	Parameter	Description	Display
0.66	11.25	Baud rate	SI01
0.67	11.23	Serial address	SI02
0.68	0.00	Spare	
0.69	0.00	Spare	
0.70	0.00	Spare	

## Speed feedback

Menu 0	Parameter	Description	Display
0.71	3.26	Speed feedback selector	Fb01
0.72	3.51	Tachometer rating (V/1000 rpm)	Fb02
0.73	3.53	Tachometer input mode	Fb03
0.74	3.52	Tachometer speed feedback	Fb04
0.75	3.34	Drive encoder lines per revolution	Fb05
0.76	3.36	Encoder supply	Fb06
0.77	3.38	Encoder type	Fb07
0.78	3.39	Encoder termination select	Fb08
0.79	3.27	Encoder speed feedback	Fb09
0.80	0.00	Spare	

## IO

Menu 0	Parameter	Description	Display
0.81	7.15	Analog input 3 mode	in01
0.82	7.01	Analog input 1	in02
0.83	7.02	Analog input 2	in03
0.84	7.03	Analog input 3	in04
0.85	8.01	I/O state 1	in05
0.86	8.02	I/O state 2	in06
0.87	8.03	I/O state 3	in07
0.88	8.04	I state 4	in08
0.89	8.05	I state 5	in09
0.90	8.06	I state 6	in10

For more information on the sub block function please refer to the *Mentor MP Advanced User Guide*.

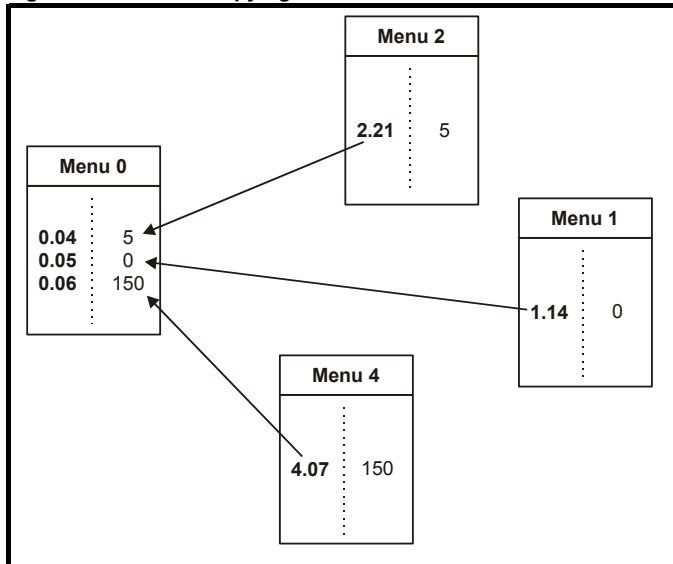
## 5.5 Menu 0 (linear)

Menu 0 is used to bring together various commonly used parameters for basic easy set up of the drive.

Appropriate parameters are copied from the advanced menus into menu 0 and thus exist in both locations.

For further information, refer to section 5.3 *Menu 0 (sub block)* on page 64.

**Figure 5-6 Menu 0 copying**



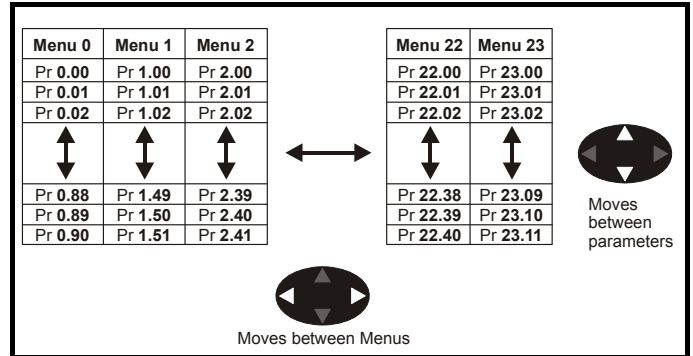
## 5.6 Menu structure

The drive parameter structure consists of menus and parameters.

The drive initially powers up in sub menu mode. Once Level 2 access (L2) has been enabled (refer to Pr 11.44 (SE14, 0.35)) the left and right buttons are used to navigate between numbered menus.

For further information, refer to section 5.13 *Parameter access level and security* on page 68.

**Figure 5-7 Menu structure**



The menus and parameters roll over in both directions.

For example:

- If the last parameter is displayed, a further press will cause the display to roll-over and show the first parameter.
- When changing between menus the drive remembers which parameter was last viewed in a particular menu and will display that parameter. The menus and parameters roll over in both directions.

## 5.7 Advanced menus

The advanced menus consist of groups or parameters appropriate to a specific function or feature of the drive. Menus 0 to 23 can be viewed on both keypads. Menus 40 and 41 are specific to the MP-Keypad (LCD). Menus 70 to 91 can be viewed with an MP-Keypad (LCD) only when an SM-Applications module is installed.

**Table 5-2 Advanced menu descriptions**

Menu	Description	LED	LCD
0	Commonly used basic set up parameters for quick / easy programming	✓	✓
1	Speed reference	✓	✓
2	Ramps	✓	✓
3	Speed feedback and speed control	✓	✓
4	Torque and current control	✓	✓
5	Motor control including field regulator	✓	✓
6	Sequencer and clock	✓	✓
7	Analog I/O	✓	✓
8	Digital I/O	✓	✓
9	Programmable logic, motorized pot and binary sum	✓	✓
10	Status and trips	✓	✓
11	General drive set-up	✓	✓
12	Threshold detectors and variable selectors	✓	✓
13	Position control	✓	✓
14	User PID controller	✓	✓
15	Solutions Module set-up	✓	✓
16	Solutions Module set-up	✓	✓
17	Solutions Module set-up	✓	✓
18	Application menu 1	✓	✓
19	Application menu 2	✓	✓
20	Application menu 3	✓	✓
21	Second motor parameters	✓	✓
22	Menu 0 set-up - user area	✓	✓
23	Menu 0 sub block control	✓	✓
40	Keypad configuration menu	X	✓
41	User filter menu	X	✓
70	PLC registers	X	✓
71	PLC registers	X	✓
72	PLC registers	X	✓
73	PLC registers	X	✓
74	PLC registers	X	✓
75	PLC registers	X	✓
85	Timer function parameters	X	✓
86	Digital I/O parameters	X	✓
88	Status parameters	X	✓
90	General parameters	X	✓
91	Fast access parameters	X	✓

**Key:** ✓ = Available  
X = Not available

**Table 5-3 Menu 40 parameter descriptions**

Parameter	Range(⇅)
40.00	Parameter 0 0 to 32767
40.01	Language selection English (0), Custom (1), French (2), German (3), Spanish (4), Italian (5)
40.02	Software version 999999
40.03	Save to flash Idle (0), Save (1), Restore (2), Default (3)
40.04	LCD contrast 0 to 31
40.05	Drive and attribute database upload was bypassed Updated (0), Bypass (1)
40.06	Browsing favourites control Normal (0), Filter (1)
40.07	Keypad security code 0 to 999
40.08	Communication channel selection Disable (0), Slot1 (1), Slot2 (2), Slot3 (3), Slave (4), Direct (5)
40.09	Hardware key code 0 to 999
40.10	Drive node ID (Address) 0 to 255
40.11	Flash ROM memory size 4Mbit (0), 8Mbit (1)
40.19	String database version number 0 to 999999
40.20	Screen saver strings and enable None (0), Default (1), User (2)
40.21	Screen saver interval 0 to 600
40.22	Turbo browse time interval 0 to 200 ms
40.23	Product identification Unidrive SP (0), Commander SK (1), Mentor MP (2), Affinity (4), Digitax ST (5)

**Table 5-4 Menu 41 parameter descriptions**

Parameter	Range(⇅)
41.00	Parameter 0 0 to 32767
41.01 to 41.50	Browsing filter source F01 to F50 Pr 0.00 to Pr 22.99
41.51	Browsing favourites control Normal (0), Filter (1)

## 5.8 Saving parameters

When changing a parameter in Menu 0, the new value is saved when pressing the **M** Mode button to return to parameter view mode from parameter edit mode.

If parameters have been changed in the advanced menus, then the change will not be saved automatically. A save function must be carried out.

### Procedure

- Enter SAVE in Pr **xx.00**
- Either:
  - Press the red  reset button
  - Toggle the reset digital input, or
  - Carry out a drive reset through serial communications by setting Pr **10.38** to 100 (ensure that Pr **xx.00** returns to 0).

## 5.9 Restoring parameter defaults


Restoring parameter defaults by this method saves the default values in the drive's memory. (Pr **11.44** (SE14, 0.35) and Pr **11.30** are not affected by this procedure).

### Procedure

- Ensure the drive is not enabled, i.e. terminal 31 is open or Pr **6.15** is OFF (0)
- Select Eur or USA in Pr **xx.00**.



3. Either:

- Press the red  reset button
- Toggle the reset digital input, or
- Carry out a drive reset through serial communications by setting Pr 10.38 to 100 (ensure that Pr. xx.00 returns to 0).

## 5.10 Differences between European and USA defaults

Pr	Description	Default
2.06	S ramp enable	Eur: OFF (0), USA: On (1)
3.51	Tachometer voltage rating (Fb02, 0.72)	Eur: 60.00, USA: 50.00
5.09, 21.09	Armature rated voltage (SE06, 0.27)	480 V drive Eur: 440, USA:500
5.28	Field weakening compensation disable	Eur: OFF (0), USA On (1)
5.59, 21.08	Back emf set point	480V drive Eur: 440, USA:500
5.65	Economy timeout	Eur: OFF (0), USA: On (1)
5.70, 21.24	Rated field current (SE10, 0.31)	Size 1: Eur: 2.00, USA: 8.00 Size 2A & B Eur: 3.00, USA: 20.00 Size 2C & D Eur: 5.00, USA 20.00
5.73, 21.23	Rated field voltage (SE11, 0.32)	Eur: 360, USA: 300
5.75	Field voltage mode	Eur: OFF (0), USA: On (1)
7.15	Analog input 3 mode (in01, 0.81)	Eur: th (8), USA: VOLT (6)

## 5.11 Displaying parameters with non-default values only

Select dIS.dEfl in Pr xx.00, the only parameters that will be visible to the user will be those containing a non-default value. This function does not require a drive reset to become active. To deactivate this function, return to Pr xx.00 and enter a value of 0.

Please note that this function can be affected by the access level enabled. You must refer to section 5.13 *Parameter access level and security* for more information regarding access level.

## 5.12 Displaying destination parameters only

Select dIS.dESt in Pr xx.00, the only parameters that will be visible to the user will be destination parameters. This function does not require a drive reset to become active. To deactivate this function, return to Pr xx.00 and enter a value of 0.

Please note that this function can be affected by the access level enabled You must refer to section 5.13 *Parameter access level and security* for further information regarding access levels.

## 5.13 Parameter access level and security

The parameter access levels determine whether the user has access to Menu 0 (in sub block mode) only or to all of the advanced menus (Menus 1 to 23), in addition to Menu 0 (in linear mode).

The user security determines whether the access to the user is read only or read write.

The user security and the parameter access level can operate independently of each other as shown in Table 5-5 .

**Table 5-5 User security and parameter access levels**

Parameter access level	User security	Menu 0 status	Advanced menus status
L1	Open	Sub block RW	Not visible
L1	Closed	Sub block RO	Not visible
L2	Open	Linear RW	RW
L2	Closed	Linear RO	RO

RW = Read / write access RO = Read only access

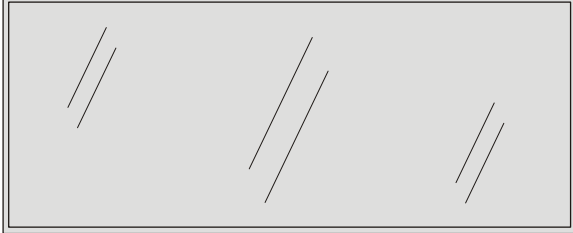
The default settings of the drive are parameter access level L1 and User Security Open, i.e. read / write access to Menu 0 with the advanced menus, not visible

### 5.13.1 User security

The user security, when set, prevents write access to any of the parameters (other than Pr 11.44 (SE14, 0.35) Access Level) in any menu.

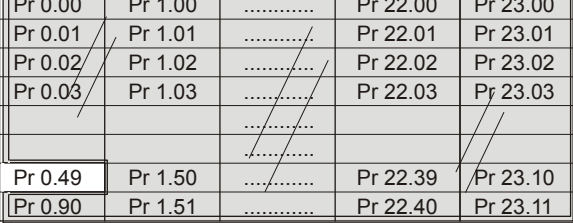
**Figure 5-8 User security open**

**User security open - All parameters: Read / Write access**




Pr 0.00	Pr 1.00	.....	Pr 22.00	Pr 23.00
Pr 0.01	Pr 1.01	.....	Pr 22.01	Pr 23.01
Pr 0.02	Pr 1.02	.....	Pr 22.02	Pr 23.02
Pr 0.03	Pr 1.03	.....	Pr 22.03	Pr 23.03
		.....		
		.....		
Pr 0.89	Pr 1.50	.....	Pr 22.39	Pr 23.10
Pr 0.90	Pr 1.51	.....	Pr 22.40	Pr 23.11

**User security closed - All parameters: Read Only access (except Pr 11.44 (SE14, 0.35))**





Pr 0.00	Pr 1.00	.....	Pr 22.00	Pr 23.00
Pr 0.01	Pr 1.01	.....	Pr 22.01	Pr 23.01
Pr 0.02	Pr 1.02	.....	Pr 22.02	Pr 23.02
Pr 0.03	Pr 1.03	.....	Pr 22.03	Pr 23.03
		.....		
		.....		
Pr 0.49	Pr 1.50	.....	Pr 22.39	Pr 23.10
Pr 0.90	Pr 1.51	.....	Pr 22.40	Pr 23.11


### 5.13.2 Setting user security

Enter a value between 1 and 999 in Pr 11.30 and press the  button; the security code has now been set to this value. To activate the security, the access level must be set to Loc in Pr 11.44 (SE14, 0.35). When the drive is reset, the security code will have been activated and the drive returns to access level L1. The value of Pr 11.30 will return to 0 in order to hide the security code. At this point, the only parameter that can be changed by the user is the access level Pr 11.44 (SE14, 0.35).

### 5.13.3 Unlocking user security

Select a read write parameter to be edited and press the  button; the upper display will now show CodE.

Use the arrow buttons to set the security code and press the  button. With the correct security code entered, the display will revert to the parameter selected in edit mode. If an incorrect security code is entered the display will revert to parameter view mode.

To lock the user security again, set Pr 11.44 (SE14, 0.35) to Loc and press the  reset button.



### 5.13.4 Disabling user security

Unlock the previously set security code as detailed above. Set Pr 11.30 to 0 and press the **M** button. The user security has now been disabled, and will not have to be unlocked each time the drive is powered up to allow read / write access to the parameters.

## 5.14 Serial communications

### 5.14.1 Introduction

The Mentor MP has a standard 2-wire EIA485 interface (serial communications interface) which enables all drive set-up, operation and monitoring to be carried out with a PC or controller if required. Therefore, it is possible to control the drive entirely by serial communications without the need for a keypad or other control cabling. The drive supports two protocols selected by parameter configuration:

- Modbus RTU
- CT ANSI

Modbus RTU has been set as the default protocol, as it is used with the PC-tools commissioning/start-up software as provided at [www.controltechniques.com](http://www.controltechniques.com).

The serial communications port of the drive is a RJ45 socket, which is isolated from the power stage and the other control terminals (see section 4.10 *Serial communications connections* on page 54 for connection and isolation details).

The communications port applies a 2 unit load to the communications network.

#### USB/EIA232 to EIA485 Communications

An external USB/EIA232 hardware interface such as a PC cannot be used directly with the 2-wire EIA485 interface of the drive. Therefore a suitable converter is required.

Suitable USB to EIA485 and EIA232 to EIA485 isolated converters are available from Control Techniques as follows:

- CT USB Comms cable (CT Part No. 4500-0096)
- CT EIA232 Comms cable (CT Part No. 4500-0087)

When using one of the above converters or any other suitable converter with the Mentor MP, it is recommended that no terminating resistors be connected on the network. It may be necessary to 'link out' the terminating resistor within the converter depending on which type is used. The information on how to link out the terminating resistor will normally be contained in the user information supplied with the converter.

### 5.14.2 Serial communications set-up parameters

The following parameters need to be set according to the system requirements.

<b>11.24</b>		<b>Serial mode</b>											
RW	Txt												US
⇅		AnSI (0), rTU (1), Lcd (2)										⇒	rTU (1)

This parameter defines the communications protocol used by the 485 comms port on the drive. This parameter can be changed via the drive keypad, via a Solutions Module or via the comms interface itself. If it is changed via the comms interface, the response to the command uses the original protocol. The master should wait at least 20 ms before sending a new message using the new protocol. (Note: ANSI uses 7 data bits, 1 stop bit and even parity; Modbus RTU uses 8 data bits, 2 stops bits and no parity).

Comms value	String	Communications mode
0	AnSI	ANSI
1	rTU	Modbus RTU protocol
2	Lcd	Modbus RTU protocol, but with a MP-Keypad only

### ANSIx3.28 protocol

Full details of the CT ANSI communications protocol are in the *Mentor MP Advanced User Guide*.

### Modbus RTU protocol

Full details of the CT implementation of Modbus RTU are given in the *Mentor MP Advanced User Guide*.

### Modbus RTU protocol, but with an MP-Keypad only

This setting is used for disabling communications access when the MP-Keypad is used as a hardware key.

<b>Si01</b>		<b>Baud rate</b>											
RW	Txt												US
⇅		300 (0), 600 (1), 1200 (2), 2400 (3), 4800 (4), 9600 (5), 19200 (6), 38400 (7), 57600 (8)*, 115200 (9)*										⇒	19200 (6)

Used in all comms modes to define the baud rate.

Parameter value	String/baud rate
0	300
1	600
2	1200
3	2400
4	4800
5	9600
6	19200
7	38400
8*	57600
9*	115200

\* Only applicable to Modbus RTU mode

This parameter can be changed via the drive keypad, via a Solutions Module or via the comms interface itself. If it is changed via the comms interface, the response to the command uses the original baud rate. The master should wait at least 20 ms before sending a new message using the new baud rate.

#### NOTE

When using the CT EIA232 Comms cable the available baud rate is limited to 19.2k baud.

<b>Si02</b>		<b>Serial address</b>											
RW	Txt												US
⇅		0 to 247										⇒	1

Used to define the unique address for the drive for the serial interface. The drive is always a slave.

### ANSI

When the ANSI protocol is used the first digit is the group and the second digit is the address within a group. The maximum permitted group number is 9 and the maximum permitted address within a group is 9. Therefore, Pr 11.23 (Si02, 0.67) is limited to 99 in this mode. The value 00 is used to globally address all slaves on the system, and x0 is used to address all slaves of group x, therefore these addresses should not be set in this parameter.

### Modbus RTU

When the Modbus RTU protocol is used addresses between 0 and 247 are permitted. Address 0 is used to globally address all slaves, and so this address should not be set in this parameter.

## 6 Basic parameters

The pre-defined sub blocks contain commonly used parameters for basic set-up of the Mentor MP. All parameters in the pre-defined sub blocks appear in other menus in the drive. (Denoted by {x.xx} in Table 6-1.)

**Table 6-1 Pre-defined sub block parameters**

Parameter		Range(⇅)	Default(⇨)	Type						
SE00	Parameter zero	{0.21, x.00}	0 to 32,767	0	RW	Uni				
SE01	Minimum reference clamp	{0.22, 1.07}	±SPEED_LIMIT_MAX rpm	0.0	RW	Bi			PT	US
SE02	Maximum reference clamp	{0.23, 1.06}	SPEED_LIMIT_MAX rpm	1000.0	RW	Bi				US
SE03	Acceleration rate	{0.24, 2.11}	0 to MAX_RAMP_RATE s/(SE02 [Pr 0.23, 1.06] or Pr 2.39)	5.000	RW	Uni				US
SE04	Deceleration rate	{0.25, 2.21}	0 to MAX_RAMP_RATE s/(SE02 [Pr 0.23, 1.06] or Pr 2.39)	5.000	RW	Uni				US
SE05	Reference selector	{0.26, 1.14}	A1.A2 (0), A1.Pr (1), A2.Pr (2), Pr (3), PAD (4), Prc (5), PAD rEF (6)	A1.A2 (0)	RW	Txt				US
SE06	Armature rated voltage	{0.27, 5.09}	0 to ARMATURE_VOLTAGE_MAX Vdc	For 480 V drive: 440 Eur 500 USA For 575 V drive: 630 Eur 630 USA For 690 V drive: 760 Eur 760 USA	RW	Uni	RA			US
SE07	Motor rated current	{0.28, 5.07}	0 to RATED_CURRENT_MAX A	RATED_CURRENT_MAX	RW	Uni	RA			US
SE08	Base speed	{0.29, 5.08}	0.0 to 10,000.0 rpm	1000.0	RW	Uni				US
SE09	Parameter copying	{0.30, 11.42}	nonE (0), rEAd (1), ProG (2), Auto (3), boot (4)	nonE (0)	RW	Txt			*	NC
SE10	Rated field current	{0.31, 5.70}	0 to FIELD_CURRENT_SET_MAX	Size 1: Eur 2A, USA 8 A Size 2A/B: Eur 3A, USA 20 A Size 2C/D: Eur 5A, USA 20 A	RW	Uni			PT	US
SE11	Rated field voltage	{0.32, 5.73}	0 to 500 Vdc	Eur: 360, USA: 300	RW	Uni			PT	US
SE12	Enable field control	{0.33, 5.77}	OFF (0) or On (1)	OFF (0)	RW	Txt				US
SE13	Autotune	{0.34, 5.12}	0 to 3	0	RW	Uni			NC	
SE14	Security status	{0.35, 11.44}	L1 (0), L2 (1), Loc (2)	L1 (0)	RW	Txt			PT	US
di01	Speed reference selected	{0.36, 1.01}	±MAX_SPEED_REF rpm		RO	Bi			NC	PT
di02	Pre-ramp reference	{0.37, 1.03}	±MAX_SPEED_REF rpm		RO	Bi			NC	PT
di03	Post ramp reference	{0.38, 2.01}	±SPEED_MAX rpm		RO	Bi			NC	PT
di04	Final speed reference	{0.39, 3.01}	±SPEED_MAX rpm		RO	Bi	FI		NC	PT
di05	Speed feedback	{0.40, 3.02}	±SPEED_MAX rpm		RO	Bi	FI		NC	PT
di06	Speed controller output	{0.41, 3.04}	±TORQUE_PRODUCT_CURRENT_MAX %		RO	Bi	FI		NC	PT
di07	Torque demand	{0.42, 4.03}	±TORQUE_PROD_CURRENT_MAX %		RO	Bi	FI		NC	PT
di08	Current magnitude	{0.43, 4.01}	0 to DRIVE_CURRENT_MAX A		RO	Uni	FI		NC	PT
di09	Field current feedback	{0.44, 5.56}	±50.00 A		RO	Bi	FI		NC	PT
di10	Armature voltage	{0.45, 5.02}	±ARMATURE_VOLTAGE_MAX V		RO	Bi	FI		NC	PT
di11	Reference enabled indicator	{0.46, 1.11}	OFF (0) or On (1)		RO	Bit			NC	PT
di12	Reverse selected indicator	{0.47, 1.12}	OFF (0) or On (1)		RO	Bit			NC	PT
di13	Jog selected indicator	{0.48, 1.13}	OFF (0) or On (1)		RO	Bit			NC	PT
di14	Software version	{0.49, 11.29}	1.00 to 99.99		RO	Uni			NC	PT
tr01	Trip 0	{0.51, 10.20}			RO	Txt			NC	PT
tr02	Trip 1	{0.52, 10.21}			RO	Txt			NC	PT
tr03	Trip 2	{0.53, 10.22}			RO	Txt			NC	PT
tr04	Trip 3	{0.54, 10.23}			RO	Txt			NC	PT
tr05	Trip 4	{0.55, 10.24}			RO	Txt			NC	PT
tr06	Trip 5	{0.56, 10.25}	0 to 229		RO	Txt			NC	PT
tr07	Trip 6	{0.57, 10.26}			RO	Txt			NC	PT
tr08	Trip 7	{0.58, 10.27}			RO	Txt			NC	PT
tr09	Trip 8	{0.59, 10.28}			RO	Txt			NC	PT
tr10	Trip 9	{0.60, 10.29}			RO	Txt			NC	PT
SP01	(Kp1) Speed controller proportional gains	{0.61, 3.10}	0.0000 to 6.5535 (1 / (rad/s))	0.0300	RW	Uni				US
SP02	(Ki1) Speed controller integral gains	{0.62, 3.11}	0.00 to 655.35 (s / (rad/s))	0.10	RW	Uni				US
SP03	(Kd1) Speed controller differential feedback gains	{0.63, 3.12}	0.00000 to 0.65535 (1/s / (rad/s))	0.00000	RW	Uni				US
Si01	Serial comms baud rate	{0.66, 11.25}	300 (0), 600 (1), 1200 (2), 2400 (3), 4800 (4), 9600 (5), 19200 (6), 38400 (7), 57600 (8)** , 115200 (9)**	19200 (6)	RW	Txt				US
Si02	Serial comms address	{0.67, 11.23}	0 to 247	1	RW	Uni				US
Fb01	Speed feedback selector	{0.71, 3.26}	drv (0), Slot1 (1), Slot2 (2), Slot3 (3), tACHO (4), Est SPEED (5)	Est SPEED (5)	RW	Txt				US
Fb02	Tachometer voltage rating	{0.72, 3.51}	0 to 300.00 V/1000 rpm	Eur: 60.00, USA: 50.00	RW	Uni				US
Fb03	Tachometer input mode	{0.73, 3.53}	DC (0), DC Filtr (1), AC (2)	DC (0)	RW	Txt				US
Fb04	Tachometer speed feedback	{0.74, 3.52}	±SPEED_MAX rpm		RO	Bi	FI		NC	PT
Fb05	Drive encoder lines per revolution	{0.75, 3.34}	1 to 50,000	1,024	RW	Uni				US

Parameter		Range(↕)	Default(⇒)	Type					
Fb06	Drive encoder supply voltage {0.76, 3.36}	5 V (0), 8 V (1), 15 V (2), 24 V (3)	5 V (0)	RW	Txt				US
Fb07	Drive encoder type {0.77, 3.38}	Ab (0), Fd (1), Fr (2)	Ab (0)	RW	Txt				US
Fb08	Drive encoder termination select {0.78, 3.39}	0 to 2	1	RW	Uni				US
Fb09	Drive encoder speed feedback {0.79, 3.27}	±10,000.0 rpm		RW	Bi	FI	NC	PT	US
in01	Analog input 3 mode {0.81, 7.15}	0-20 (0), 20-0 (1), 4-20.tr (2), 20-4.tr (3), 4-20 (4), 20-4 (5), VOLt (6), th.SC (7), th (8), th.diSp (9)	th (8)	RW	Txt				US
in02	Analog input 1 {0.82, 7.01}	±100.00 %		RO	Bi		NC	PT	
in03	Analog input 2 {0.83, 7.02}	±100.0 %		RO	Bi		NC	PT	
in04	Analog input 3 {0.84, 7.03}	±100.0 %		RO	Bi		NC	PT	
in05	T24 digital I/O 1 state {0.85, 8.01}			RO	Bit		NC	PT	
in06	T25 digital I/O 2 state {0.86, 8.02}			RO	Bit		NC	PT	
in07	T26 digital I/O 3 state {0.87, 8.03}			RO	Bit		NC	PT	
in08	T27 digital input 4 state {0.88, 8.04}	OFF (0) or On (1)		RO	Bit		NC	PT	
in09	T28 digital input 5 state {0.89, 8.05}			RO	Bit		NC	PT	
in10	T29 digital input 6 state {0.90, 8.06}			RO	Bit		NC	PT	

\* Modes 1 and 2 are not user saved, Modes 0, 3 and 4 are user saved.

\*\* Only applicable to Modbus RTU mode.

Key:

Coding	Attribute
{X.XX}	Copied Menu 0 or advanced parameter
RW	Read/write: can be written by the user
RO	Read only: can only be read by the user
Bit	1 bit parameter: 'On' or 'OFF' on the display
Bi	Bipolar parameter
Uni	Unipolar parameter
Txt	Text: the parameter uses text strings instead of numbers.
FI	Filtered: some parameters which can have rapidly changing values are filtered when displayed on the drive keypad for easy viewing.
DE	Destination: This parameter selects the destination of an input or logic function.
RA	Rating dependent: this parameter is likely to have different values and ranges with drives of different voltage and current ratings. Parameters with this attribute will not be transferred to the destination drive by SMARTCARDS when the rating of the destination drive is different from the source drive and the file is a parameter file. However, the value will be transferred if only the current rating is different and the file is a differences from default type file.
NC	Not copied: not transferred to or from SMARTCARDS during copying.
PT	Protected: cannot be used as a destination.
US	User save: parameter saved in drive EEPROM when the user initiates a parameter save.
PS	Power-down save: parameter automatically saved in drive EEPROM when the under volts (UV) trip occurs. Power-down save parameters are also saved in the drive when the user initiates a parameter save.

## 6.1 Full descriptions

### 6.1.1 Parameter x.00

SE00 {x.00}	Parameter zero								
RW	Uni								
↕		0 to 32,767				⇒	0		

Pr x.00 is available in all menus and has the following functions.

Value	String	Action
0	No Act	No action
1	SAUE	Save parameters
2	rEAd 1*	Transfer SMARTCARD data block 1 to the drive
3	PrOg 1*	Transfer drive parameters as difference from default to SMARTCARD block number 1
4	rEAd 2*	Transfer SMARTCARD data block 2 to the drive
5	PrOg 2*	Transfer drive parameters as difference from default to SMARTCARD block number 2
6	rEAd 3*	Transfer SMARTCARD data block 3 to the drive
7	PrOg 3*	Transfer drive parameters as difference from default to SMARTCARD block number 3
8	diS.diFF	Display non-default values only
9	diS.dESt	Display destination parameters only
10	Eur	Load European defaults
11	USA	Load USA defaults
12	rES OP	Reset all Solution Modules
1000	1000	Save parameters
1070	1070	Reset all Solution Modules
1233	1233	Load European defaults
1244	1244	Load USA defaults
1255	1255	Load European defaults (excluding menus 15 to 20)
1256	1256	Load USA defaults (excluding menus 15 to 20)
2001	2001*	Transfer drive parameter to a card and create a bootable difference from default SMARTCARD block with data block number 1 and clear parameter 11.42. If data block 1 exists it is over written.
3yyy	3yyy*	Transfer drive parameters to SMARTCARD block number yyy
4yyy	4yyy*	Transfer drive parameters as difference from default to SMARTCARD block number yyy
5yyy	5yyy*	Transfer Onboard Applications Lite ladder program to SMARTCARD block number yyy
6yyy	6yyy*	Transfer SMARTCARD data block yyy to the drive
7yyy	7yyy*	Erase SMARTCARD data block yyy
8yyy	8yyy*	Compare drive data with SMARTCARD block yyy
9555	9555*	Clear SMARTCARD warning suppression flag
9666	9666*	Set SMARTCARD warning suppression flag
9777	9777*	Clear SMARTCARD read-only flag
9888	9888*	Set SMARTCARD read-only flag
9999	9999*	Erase SMARTCARD
12000**	12000**	Display non-default values only
12001**	12001**	Display destination parameters only

\* See Chapter 9 SMARTCARD operation on page 88 for more information of these functions.

\*\* These functions do not require a drive reset to become active. All other functions require a drive reset to initiate the function.

### 6.1.2 Parameter x.00 reset

When an action is started by setting Pr x.00 to one of the above values and initiating a drive reset this parameter is cleared when the action is completed successfully. If the action is not started, e.g. because the drive is enabled and an attempt is made to load defaults, etc., Pr x.00 is not cleared and no trip is produced. If the action is started and then fails for some reason a trip is always produced and Pr x.00 is not cleared. It should be noted that parameter saves etc. can also be initiated with the copying parameter (Pr 11.42 (SE09, 0.30)). If actions that can be initiated by either parameter are started and then completed successfully Pr x.00 is cleared and Pr 11.42 (SE09, 0.30) is cleared if it has a value of less than 3.

It should be noted that there could be some conflict between the actions of Pr x.00 and Pr 11.42 (SE09, 0.30) *Parameter copying* when the drive is reset. If Pr 11.42 (SE09, 0.30) has a value of 1 or 2 and a valid action is required from the value of Pr x.00 then only the action required by Pr x.00 is performed. Pr x.00 and Pr 11.42 (SE09, 0.30) are then reset to zero. If Pr 11.42 (SE09, 0.30) has a value of 3 or 4 it will operate correctly causing parameters to be save to a SMARTCARD each time a parameter save is performed.

### 6.1.3 Set-up

<b>SE01</b> {0.22, 1.07}		<b>Minimum reference clamp</b>												
RW	Bi												PT	US
↕		±SPEED_LIMIT_MAX rpm										⇒	0.0	

(When the drive is jogging, this parameter has no effect.)

Set SE01 (Pr 0.22, 1.07) at the required minimum motor speed for both directions of rotation. The drive speed reference is scaled between SE01 (Pr 0.22, 1.07) and SE02 (Pr 0.23, 1.06).

<b>SE02</b> {0.23, 1.06}		<b>Maximum reference clamp</b>												
RW	Bi													US
↕		SPEED_LIMIT_MAX rpm										⇒	1000.0	

(The drive has additional over-speed protection.)

Set SE02 (Pr 0.23, 1.06) at the required maximum motor speed for both directions of rotation. The drive speed reference is scaled between SE01 (Pr 0.22, 1.07) and SE02 (Pr 0.23, 1.06).

<b>SE03</b> {0.24, 2.11}		<b>Acceleration rate</b>												
RW	Uni													US
↕		0 to MAX_RAMP_RATE s/(SE02 [Pr 0.23, 1.06] or Pr 2.39)										⇒	5.000	

Set SE03 (Pr 0.03, 2.11) at the required rate of acceleration.

Note that larger values produce lower acceleration. The rate applies in both directions of rotation.

<b>SE04</b> {0.25, 2.21}		<b>Deceleration rate</b>												
RW	Uni													US
↕		0 to MAX_RAMP_RATE s/(SE02 [Pr 0.23, 1.06] or Pr 2.39)										⇒	5.000	

Set Pr SE04 (Pr 0.25, 2.21) at the required rate of deceleration.

Note that larger values produce lower deceleration. The rate applies in both directions of rotation.

<b>SE05</b> {0.26, 1.14}		<b>Reference selector</b>												
RW	Txt													US
↕		A1.A2 (0), A1.Pr (1), A2.Pr (2), Pr (3), PAd (4), Prc (5), PAd rEF (6)										⇒	A1.A2 (0)	

Defines how the value of Pr 1.49 is derived as follows:

Value of Pr 1.14	Display String	Pr 1.49
0	A1.A2 (Analog ref 1. Analog ref 2)	*Selected by terminal input
1	A1.Pr (Analog ref 1. Preset speeds)	1
2	A2.Pr (Analog ref 2. Preset speeds)	2
3	Pr (Preset speeds)	3
4	Pad (Keypad reference)	4
5	Prc (Precision reference)	5
6	Pad rEF	6

\*Pr 1.41 to Pr 1.44 and Pr 1.52 can be controlled by digital inputs to force the value of Pr 1.49:

When all bits = 0, Pr 1.49 = 1

- Pr 1.41 = 1 then Pr 1.49 = 2
- Pr 1.42 = 1 then Pr 1.49 = 3
- Pr 1.43 = 1 then Pr 1.49 = 4
- Pr 1.44 = 1 then Pr 1.49 = 5
- Pr 1.52 = 1 then Pr 1.49 = 6

The bit parameters with lower numbers have priority over those with higher numbers.

Pr 1.49 and Pr 1.50 then define the reference as follows:

Pr 1.49	Pr 1.50	Reference
1	1	Analog reference 1 (Pr 1.36)
1	>1	Preset defined by Pr 1.50 (Pr 1.21 to Pr 1.28)
2	1	Analog reference 2 (Pr 1.37)
2	>1	Preset defined by Pr 1.50 (Pr 1.21 to Pr 1.28)
3	x	Preset defined by Pr 1.50 (Pr 1.21 to Pr 1.28)
4	x	Keypad reference (Pr 1.17)
5	x	Precision reference (Pr 1.18 and Pr 1.19)
6	x	Keypad reference only

x = any value

#### Keypad reference

If Keypad reference is selected the drive sequencer is controlled directly by the keypad keys and the keypad reference parameter (Pr 1.17) is selected. The sequencing bits, Pr 6.30 to Pr 6.34, have no effect and jog is disabled.

<b>SE06</b> {0.27, 5.09}		<b>Armature rated voltage</b>												
RW	Uni												RA	US
↕		0 to ARMATURE_VOLTAGE_MAX Vdc										⇒	For 480 V drive: 440 Eur, 500 USA For 575 V drive: 630 Eur, 630 USA For 690 V drive: 760 Eur, 760 USA	

<b>SE07</b> {0.28, 5.07}		<b>Motor rated current</b>											
RW	Uni					RA						US	
⇅	0 to RATED_CURRENT_MAX A					⇒	RATED_CURRENT_MAX						

The rated current should be set at the motor nameplate value for rated current. The value of this parameter is used in the following:

- Current limits
- Motor thermal protection

<b>SE08</b> {0.29, 5.08}		<b>Base speed</b>											
RW	Uni											US	
⇅	0.0 to 10,000.0 rpm					⇒	1000.0						

The rated speed defines the base speed of the motor. It is also to determine the speed used in the auto tuning inertia test (see **SE13** [Pr 0.34, 5.12]).

<b>SE09</b> {0.30, 11.42}		<b>Parameter copying</b>											
RW	Txt						NC		*				
⇅	nonE (0), rEAd (1), ProG (2), Auto (3), boot (4)					⇒	nonE (0)						

\* Modes 1 and 2 are not user saved, Modes 0, 3 and 4 are user saved.

If **SE09** (Pr 0.30, 11.42) is equal to 1 or 2 this value is not transferred to the EEPROM or the drive. If **SE09** (Pr 0.30, 11.42) is set to a 3 or 4 the value is transferred.

Pr String	Pr value	Comment
nonE	0	Inactive
rEAd	1	Read parameter set from the SMARTCARD
ProG	2	Programming a parameter set to the SMARTCARD
Auto	3	Auto save
boot	4	Boot mode

For further information, refer to Chapter 9 *SMARTCARD operation* on page 88.

<b>SE10</b> {0.31, 5.70}		<b>Rated field current</b>											
RW	Uni											PT	US
⇅	0 to FIELD_CURRENT_SET_MAX					⇒	Size 1: Eur 2A, USA 8A Size 2A/B: Eur 3A, USA 20A Size 2C/D: Eur 5A, USA 20A						

This parameter will be set to the field current of the motor and will define the rated field current for the field controller.

<b>SE11</b> {0.32, 5.73}		<b>Rated field voltage</b>											
RW	Uni											PT	US
⇅	0 to 500 Vdc					⇒	Eur: 360, USA: 300						

The maximum voltage the field controller is allowed to generate.

<b>SE12</b> {0.33, 5.77}		<b>Enable field control</b>											
RW	Txt											US	
⇅	OFF (0) or On (1)					⇒	OFF (0)						

When this parameter is set to 0 the internal and external field controllers are disabled. Setting the parameter to 1 enables the internal or external field controller.

<b>SE13</b> {0.34, 5.12}		<b>Autotune</b>											
RW	Uni											NC	
⇅	0 to 3					⇒	0						

If this parameter is set to a non-zero value, the drive is enabled and a run command is applied in either direction the drive performs an auto-tune test. All tests that rotate the motor are carried out in the forward direction if **di12** (Pr 0.47, 1.12) = 0 or the reverse direction if **di12** (Pr 0.47, 1.12) = 1. For example, if the test is initiated by applying run reverse (Pr 6.32 = 1) the test is performed in the reverse direction. The test will not start unless the drive is disabled before the test is initiated by applying the enable or run, i.e. it will not start if the drive is in the stop state. It is not possible to go into the stop state if **di12** (Pr 0.47, 1.12) has a non-zero value.

When the test is completed successfully the drive is disabled and will enter the inhibit state. The motor can only be restarted if the enable is removed either from the enable input, or Pr 6.15 is set to zero or from the control word (Pr 6.42) if it is active.

Value	Autotune function
0	None
1	Static autotune for current loop gains
2	Spinning autotune for motor saturation break points
3	Spinning autotune for inertia measurement

#### Static autotune for current loop gains

When this operation is performed, the drive will estimate the following, with respect to the selected motor map, and store the values:

- Motor constant* (Pr 5.15)
- Continuous proportional gain* (Pr 4.13)
- Continuous integral gain* (Pr 4.14)
- Discontinuous integral gain* (Pr 4.34)
- Back EMF set point* (Pr 5.59)
- Armature resistance* (Pr 5.61)
- Flux loop P gain* (Pr 5.71)
- Flux loop I gain* (Pr 5.72)

#### Spinning autotune for motor saturation break points

When this operation is performed, the drive will estimate the following, with respect to the selected motor map, and store the values:

- Motor saturation break points* (Pr 5.29, Pr 5.30), by spinning the motor at 25 % of it's base speed (Pr 5.08)
- Field current compensation factor* (Pr 5.74)

### Spinning autotune for inertia measurement

The drive can measure the total inertia of the load and motor. This is used to set the speed loop gains. See Pr 3.17 *Speed controller setup method* = 1 (bandwidth setup). During the inertia measurement test the drive attempts to accelerate the motor to  $\frac{3}{4}$  rated speed then back to a standstill. Several attempts may be made, starting with rated torque/16, and then increasing the torque progressively to  $x^{1/8}$ ,  $x^{1/4}$ ,  $x^{1/2}$ , and  $x$  1 rated torque if the motor cannot be accelerated to the required speed. If the required speed is not achieved on the final attempt the test is aborted and a tuNE 1 trip is initiated. If the test is successful the acceleration and deceleration times are used to calculate the motor and load inertia and a value is written to Pr 3.18 *Motor and load inertia*.

<b>SE14</b> {0.35, 11.44}	<b>Security status</b>												
RW	Txt									PT	US		
↕	L1 (0), L2 (1), Loc (2)						⇒	L1 (0)					

This parameter controls access via the drive keypad as follows:

Value	String	Action
0	L1	Only menu 0 can be accessed
1	L2	All menus can be accessed
2	Loc	Lock user security when drive is reset. (This parameter is set to L1 after reset.)

The keypad can adjust this parameter even when user security is set.

### 6.1.4 Diagnostic

<b>di01</b> {0.36, 1.01}	<b>Speed reference selected</b>												
RO	Bi									NC	PT		
↕	±MAX_SPEED_REF rpm						⇒						

<b>di02</b> {0.37, 1.03}	<b>Pre-ramp reference</b>												
RO	Bi									NC	PT		
↕	±MAX_SPEED_REF rpm						⇒						

<b>di03</b> {0.38, 2.01}	<b>Post ramp reference</b>												
RO	Bi									NC	PT		
↕	±SPEED_MAX rpm						⇒						

<b>di04</b> {0.39, 3.01}	<b>Final speed reference</b>												
RO	Bi	FI								NC	PT		
↕	±SPEED_MAX rpm						⇒						

This is the final speed demand at the input to the speed regulator formed by the sum of the ramp output and the hard speed reference (if the hard speed reference is enabled). If the drive is disabled this parameter will show 0.0.

<b>di05</b> {0.40, 3.02}	<b>Speed feedback</b>												
RO	Bi	FI								NC	PT		
↕	±SPEED_MAX rpm						⇒						

The speed feedback can be taken from the drive encoder port or tachometer or armature voltage or a position feedback module installed in any slot as selected with Fb01 (Pr 0.71, 3.26). di05 (Pr 0.40, 3.02) shows the level of the speed feedback selected for the speed controller. Display filtering is active when this parameter is viewed with one of the drive keypads. The value held in the drive parameter (accessible via comms or an option module) does not include this filter, but is a value that is obtained over a sliding 16 ms period to limit the ripple seen in this parameter value. The speed feedback value includes encoder quantization ripple given by the following equation:

$$\text{Ripple in di05 (Pr 0.40, 3.02)} = 60 / 16 \text{ ms} / (\text{ELPR} \times 4)$$

Where ELPR is the equivalent encoder lines per revolution as defined here:

Position feedback device	ELPR
Ab	number of lines per revolution
Fd, Fr	number of lines per revolution / 2

For example a 4096 line Ab type encoder gives a ripple level of 0.23 rpm.

**The 16 ms sliding window filter is always applied to the value shown in di05 (Pr 0.40, 3.02), but this sliding window filter is not normally applied to the actual speed feedback used by the speed controller or the drive encoder reference system (Pr 3.43 to Pr 3.46).** The user may apply a filter to the speed controller input and the drive encoder reference system input if required by setting Pr 3.42 to the required filter time. The encoder ripple seen by the speed controller is given by:

$$\text{Encoder speed ripple} = 60 / \text{Filter time} / (\text{ELPR} \times 4)$$

If Pr 3.42 is set to zero (no filter) the ripple seen by the speed controller and drive encoder reference system is given by:

$$\text{Encoder speed ripple} = 60 / 250\mu\text{s} / (\text{ELPR} \times 4)$$

**Figure 6-1 Speed feedback filter arrangement**

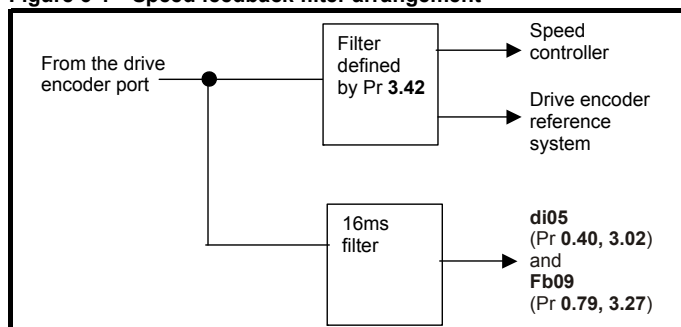


Figure 6-1 shows the filter arrangement. It should be noted that the same filtering is provided at the speed controller input and for di05 (Pr 0.40, 3.02) when the feedback is obtained from an option module, but the variable length window filter is controlled by Pr x.19.

It is not advisable to set the speed feedback filter too high unless it is specifically required for high inertia applications with high controller gains because the filter has a non-linear transfer function. It is preferable to use the current demand filters (see Pr 4.12 or Pr 4.23) as these are linear first order filters that provide filtering on noise generated from both the speed reference and the speed feedback. It should be noted that any filtering included within the speed controller feedback loop, either on the speed feedback or the current demand, introduces a delay and limits the maximum bandwidth of the controller for stable operation.

The speed ripple can be quite high, for example with a 4096 line encoder the speed ripple is 14.6 rpm, but this does not define the resolution of the speed feedback which is normally much better and depends on the length of the measuring period used to obtain the feedback. This is shown in the improved resolution of the value accessible in **di05** (Pr **0.40, 3.02**) which is measured over 16 ms, i.e. a resolution of 0.23 rpm with a 4096 line encoder. The speed controller itself accumulates all pulses from the encoder, and so the speed controller resolution is not limited by the feedback, but by the resolution of the speed reference. If a SINCOS encoder is used from an option the encoder speed ripple is reduced by a factor of  $2^{(2\text{-Interpolation bits})}$ . For example with the nominal 10 bits of interpolation information, the speed ripple is reduced by a factor of 256. This shows how a SINCOS encoder can reduce noise caused by encoder quantization without any filtering in the speed feedback or the current demand, so that high gains may be used to give high dynamic performance and a very stiff system.

<b>di06</b> {0.41, 3.04}	<b>Speed controller output</b>												
RO	Bi	FI					NC	PT					
⇕	±TORQUE_PRODUCT_CURRENT_MAX rpm											⇒	

The output of the speed regulator is a torque demand given as a percentage of rated motor torque. This is then modified to account for changes in motor flux if field weakening is active, and then used as the torque producing current reference.

<b>di07</b> {0.42, 4.03}	<b>Torque demand</b>												
RO	Bi	FI					NC	PT					
⇕	±TORQUE_PROD_CURRENT_MAX %											⇒	

The torque demand can be derived from the speed controller and/or the torque reference and offset. The units of the torque demand are a % of rated torque.

<b>di08</b> {0.43, 4.01}	<b>Current magnitude</b>												
RO	Uni	FI					NC	PT					
⇕	0 to DRIVE_CURRENT_MAX A											⇒	

The current feedback signal is derived from internal current transformers. It is used for closed loop control and indication of the armature current, and to initiate motor protection.

<b>di09</b> {0.44, 5.56}	<b>Field current feedback</b>												
RO	Bi	FI					NC	PT					
⇕	±50.00A											⇒	

Indicates the field current feedback in 0.01 amperes.

<b>di10</b> {0.45, 5.02}	<b>Armature voltage</b>												
RO	Bi	FI					NC	PT					
⇕	±ARMATURE_VOLTAGE_MAX V											⇒	

The average measured DC output voltage seen across the drive A1 and A2 terminals or the average measured DC output voltage seen across the motor. Selected by Pr **5.14**.

The armature voltage feedback has a resolution of 10-bits plus sign.

<b>di11</b> {0.46, 1.11}	<b>Reference enabled indicator</b>												
<b>di12</b> {0.47, 1.13}	<b>Reverse selected indicator</b>												
<b>di13</b> {0.48, 1.14}	<b>Jog selected indicator</b>												
RO	Bit						NC	PT					
⇕	OFF (0) or On (1)											⇒	

These parameters are controlled by the drive sequencer as defined in Menu 6. They select the appropriate reference as commanded by the drive logic. **di11** (Pr **0.46, 1.11**) will be active if a run command is given, the drive is enabled and the drive is ok. This parameter can be used as an interlock in a Onboard PLC or SM-Applications program to show that the drive is able to respond to a speed or torque demand.

<b>di14</b> {0.49, 11.29}	<b>Software version</b>												
RO	Uni						NC	PT					
⇕	1.00 to 99.99											⇒	

The parameter displays the software version of the drive.

### 6.1.5 Trips

<b>tr01</b> {0.51, 10.20}	<b>Trip 0</b>												
<b>tr02</b> {0.52, 10.21}	<b>Trip 1</b>												
<b>tr03</b> {0.53, 10.22}	<b>Trip 2</b>												
<b>tr04</b> {0.54, 10.23}	<b>Trip 3</b>												
<b>tr05</b> {0.55, 10.24}	<b>Trip 4</b>												
<b>tr06</b> {0.56, 10.25}	<b>Trip 5</b>												
<b>tr07</b> {0.57, 10.26}	<b>Trip 6</b>												
<b>tr08</b> {0.58, 10.27}	<b>Trip 7</b>												
<b>tr09</b> {0.59, 10.28}	<b>Trip 8</b>												
<b>tr10</b> {0.60, 10.29}	<b>Trip 9</b>												
RO	Txt						NC	PT					PS
⇕	0 to 229											⇒	

Contains the last 10 drive trips. **tr01** (Pr **0.51, 10.20**) is the most recent trip and **tr10** (Pr **0.60, 10.29**) the oldest. When a new trip occurs all the parameters move down one, the current trip is put in **tr01** (Pr **0.51, 10.20**) and the oldest trip is lost from the bottom of the log. Descriptions of the trips are given in Table 13-1 on page 181. All trips are stored, including HF trips numbered from 20 to 29. (HF trips with numbers from 1 to 16 are not stored in the trip log.) Any trip can be initiated by the actions described or by writing the relevant trip number to Pr **10.38**. If any trips shown as user trips are initiated the trip string is "txxx", where xxx is the trip number.

## 6.1.6 Speed loop

<b>SP01</b> {0.61, 3.10}		<b>(Kp1) Speed controller proportional gains</b>											
RW	Uni												US
↕		0.0000 to 6.5535 (1 / (rad/s))										⇒	0.0300

**SP01** (Pr 0.61/3.10) operates in the feed-forward path of the speed-control loop in the drive. See Figure 11-3 on page 110 for a schematic of the speed controller. For information on setting up the speed controller gains, refer to Chapter 8 *Optimization* on page 85.

<b>SP02</b> {0.62, 3.11}		<b>(Ki1) Speed controller integral gains</b>											
RW	Uni												US
↕		0.00 to 655.35 (s / (rad/s))										⇒	0.1

**SP02** (Pr 0.62, 3.11) operates in the feed-forward path of the speed-control loop in the drive. See Figure 11-3 on page 110 for a schematic of the speed controller. For information on setting up the speed controller gains, refer to Chapter 8 *Optimization* on page 85.

<b>SP03</b> {0.63, 3.12}		<b>(Kd1) Speed controller differential feedback gains</b>											
RW	Uni												US
↕		0.00000 to 0.65535 (1/s / (rad/s))										⇒	0.00000

**SP03** (Pr 0.63, 3.12) operates in the feed-forward path of the speed-control loop in the drive. See Figure 11-3 on page 110 for a schematic of the speed controller. For information on setting up the speed controller gains, refer to Chapter 8 *Optimization* on page 85.

## 6.1.7 Serial interface

<b>SI01</b> {0.61, 11.25}		<b>Serial comms baud rate</b>											
RW	Txt												US
↕		300 (0), 600 (1), 1200 (2), 2400 (3), 4800 (4), 9600 (5), 19200 (6), 38400 (7), 57600 (8)*, 115200 (9)*										⇒	19200 (6)

\* Only applicable to Modbus RTU mode

This parameter can be changed via the drive keypad, via a Solutions Module or via the comms interface itself. If it is changed via the comms interface, the response to the command uses the original baud rate. The master should wait at least 20 ms before send a new message using the new baud rate.

<b>SI02</b> {0.67, 11.23}		<b>Serial comms address</b>											
RW	Uni												US
↕		0 to 247										⇒	1

Used to define the unique address for the drive for the serial interface. The drive is always a slave.

### Modbus RTU

When the Modbus RTU protocol is used addresses between 0 and 247 are permitted. Address 0 is used to globally address all slaves, and so this address should not be set in this parameter

### ANSI

When the ANSI protocol is used the first digit is the group and the second digit is the address within a group.

The maximum permitted group number is 9 and the maximum permitted address within a group is nine.

Therefore, **SI02** (Pr 0.67, 11.23) is limited to 99 in this mode. The value 00 is used to globally address all slaves on the system, and x0 is used to address all slaves of group x, therefore these addresses should not be set in this parameter.

## 6.1.8 Speed feedback

<b>Fb01</b> {0.71, 3.26}		<b>Speed feedback selector</b>											
RW	Txt												US
↕		drv (0), Slot1 (1), Slot2 (2), Slot3 (3), tACHO (4), Est SPEED (5)										⇒	Est SPEED (5)

### 0, drv: Drive encoder

The position feedback from the encoder connected to the drive itself is used to derive the speed feedback for the speed controller and to calculate the motor rotor flux position.

### 1, Slot1: Solutions Module in slot 1

The position feedback from the Solutions Module in Solutions Module slot 1 is used to derive the speed feedback for the speed controller and to calculate the motor rotor flux position. If a position feedback category Solutions Module is not installed in slot 1 the drive produces an EnC9 trip.

### 2, Slot2: Solutions Module in slot 2

### 3, Slot3: Solutions Module in slot 3

### 4, tACHO: Tachometer

### 5, Est.SPEED: Estimated speed

<b>Fb02</b> {0.72, 3.51}		<b>Tachometer voltage rating</b>											
RW	Uni												US
↕		0 to 300.00 V/1000 rpm										⇒	Eur: 60.00, USA: 50.00

Defines the rating of the tachometer installed to the motor. This parameter should be set slightly above or below the nominal value if the user wishes to trim out the tolerance build ups in the feedback electronics.

<b>Fb03</b> {0.73, 3.53}		<b>Tachometer input mode</b>											
RW	Txt												US
↕		DC (0), DC Filt (1), AC (2)										⇒	DC (0)

The input electronics for the tachometer input can be configured in 3 ways.

Value	Text	Action
0	DC	DC tachometer
1	DC Filt	DC tachometer with input filter
2	AC	AC tachometer

<b>Fb04</b> {0.74, 3.52}		<b>Tachometer speed feedback</b>											
RO	Bi	FI						NC	PT				
↕		±SPEED_MAX rpm										⇒	

Provided the tachometer voltage rating parameter for the tachometer is correct this parameter shows the tachometer speed in rpm.



<b>Fb05</b> {0.75, 3.34}		<b>Drive encoder lines per revolution</b>											
RW	Uni												US
⇅	1 to 50,000						⇒	1,024					

When Ab, Fd, Fr are used the equivalent number of encoder lines per revolution must be set-up correctly in **Fb05** (Pr **0.75, 3.34**) to give the correct speed and position feedback. This is particularly important if the encoder is selected for speed feedback with **Fb01** (Pr **0.71, 3.26**). The equivalent number of encoder lines per revolution (ELPR) is defined as follows.:

<b>Position feedback device</b>		<b>ELPR</b>
Ab	number of lines per revolution	
Fd, Fr	number of lines per revolution / 2	

The incremental (A/B) signal frequency should not exceed 500 kHz. If **Fb05** (Pr **0.75, 3.34**) is changed the encoder is re-initialized.

<b>Fb06</b> {0.76, 3.36}		<b>Drive encoder supply voltage</b>											
RW	Txt												US
⇅	5 V (0), 8 V (1), 15 V (2), 24 V (3)						⇒	5 V (0)					

The encoder supply voltage present on the drive encoder connector is defined by this parameter as 0 (5 V), 1 (8 V), 2 (15 V) or 3 (24 V)

<b>Fb07</b> {0.77, 3.38}		<b>Drive encoder type</b>											
RW	Txt												US
⇅	Ab (0), Fd (1), Fr (2)						⇒	Ab (0)					

The following encoders can be connected to the drive encoder port.

**0, Ab:** Quadrature incremental encoder, with or without marker pulse.

**1, Fd:** Incremental encoder with frequency and direction outputs, with or without marker pulse.

**2, Fr:** Incremental encoder with forward and reverse outputs, with or without marker pulse.

<b>Fb08</b> {0.78, 3.39}		<b>Drive encoder termination select</b>											
RW	Uni												US
⇅	0 to 2						⇒	1					

The terminations may be enabled/disabled by this parameter as follows:

Encoder input	Fb08 {0.78, 3.39} = 0	Fb08 {0.78, 3.39} = 1	Fb08 {0.78, 3.39} = 2
A-A\	Disabled	Enabled	Enabled
B-B\	Disabled	Enabled	Enabled
Z-Z\	Disabled	Disabled	Enabled

<b>Fb09</b> {0.79, 3.27}		<b>Drive encoder speed feedback</b>											
RW	Bi	FI					NC	PT	US				
⇅	±10,000.0 rpm						⇒						

Provided the set-up parameters for the drive encoder are correct this parameter shows the encoder speed in rpm.

It should be noted that the value shown by this parameter is measured over a 16 ms sliding window period (in the same way as **di05** (Pr **0.40, 3.02**)), and so the ripple in this parameter accessible via comms or by an Solutions Module is as defined for **di05** (Pr **0.40, 3.02**).

The FI attribute for this parameter is set, and so further filtering is applied when this parameter is viewed with one of the drive keypads.

### 6.1.9 I/O

<b>in01</b> {0.81, 7.15}		<b>Analog input 3 mode</b>											
RW	Txt												US
⇅	0-20 (0), 20-0 (1), 4-20.tr (2), 20-4.tr (3), 4-20 (4), 20-4 (5), VOLt (6), th.SC (7), th (8), th.diSp (9)						⇒	Eur: th (8), USA: VOLt (6)					

The following modes are available for the analog input 3. In modes 2 and 3, a current loop loss trip is generated if the input current falls below 3 mA. In modes 4 and 5 the analog input level goes to 0.0 % if the input current falls below 3 mA.

Parameter value	Parameter string	Mode	Comments
0	0-20	0 - 20 mA	
1	20-0	20 - 0 mA	
2	4-20.tr	4 -20 mA with trip on loss	Trip if I < 3 mA
3	20-4.tr	20 - 4 mA with trip on loss	Trip if I < 3 mA
4	4-20	4 - 20 mA with no trip on loss	
5	20-4	20 - 4 mA with no trip on loss	0.0 % if I < 4 mA
6	VOLt	Voltage mode	
7	th.SC	Thermistor with short circuit detection	TH trip if R > 3 k 3 TH reset if R < 1 k 8 THS trip if R < 50 R
8	th	Thermistor without short circuit detection	TH trip if R > 3 k 3 TH reset if R < 1 k 8
9	th.diSp	Thermistor display only with no trip	

In modes 2 and 4 the destination parameter is at a value equivalent to 0.0 % when the input current is less than 4 mA. In modes 3 and 5 the destination parameter is at a value equivalent to 100.0 % when the input current is less than 4 mA.

<b>in02</b> {0.82, 7.01}		<b>Analog input 1</b>											
RO	Bi											NC	PT
⇅	±100.00 %						⇒						

<b>in03</b> {0.83, 7.02}		<b>Analog input 2</b>											
RO	Bi											NC	PT
⇅	±100.0 %						⇒						

<b>in04</b> <b>{0.84, 7.03}</b>		<b>Analog input 3</b>											
RO	Bi						NC	PT					
↕	±100.0 %					⇒							

When analog input 3 is in thermistor mode the display indicates the resistance of the thermistor as a percentage of 10 k Ω.


<b>in05</b> <b>{0.85, 8.01}</b>		<b>T24 digital I/O 1 state</b>											
<b>in06</b> <b>{0.86, 8.02}</b>		<b>T25 digital I/O 2 state</b>											
<b>in07</b> <b>{0.87, 8.03}</b>		<b>T26 digital I/O 3 state</b>											
<b>in08</b> <b>{0.88, 8.04}</b>		<b>T27 digital input 4 state</b>											
<b>in09</b> <b>{0.89, 8.05}</b>		<b>T28 digital input 5 state</b>											
<b>in10</b> <b>{0.90, 8.06}</b>		<b>T29 digital input 6 state</b>											
RO	Bit						NC	PT					
↕	OFF (0) or On (1)					⇒							

OFF (0) = Terminal inactive

On (1) = Terminal active


# 7 Running the motor

This chapter takes the new user through all the essential steps to running a motor for the first time, in each of the possible operating modes.




Ensure that no damage or safety hazard could arise from the motor starting unexpectedly.


**WARNING**




The values of the motor parameters affect the protection of the motor.  
The default values in the drive should not be relied upon. It is essential that the correct value is entered in Pr **5.07 (SE07, 0.28) Motor rated current**. This affects the thermal protection of the motor.

**CAUTION**



If the keypad mode has been used previously, ensure that the keypad reference has been set to 0 using the  buttons as if the drive is started using the keypad it will run to the speed defined by the keypad reference (Pr **1.17**).

**CAUTION**



If the intended maximum speed affects the safety of the machinery, additional independent over-speed protection must be used.



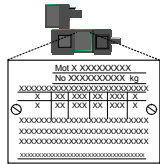

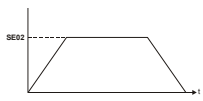
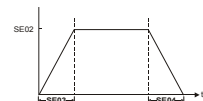
**WARNING**




**Table 7-1 Minimum control connection requirements for each control mode**

Drive control method	Requirements
Terminal mode	Drive enable Speed reference Run forward or run reverse command
Keypad mode	Drive enable
Serial communications	Drive enable Serial communications link



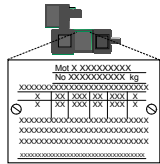

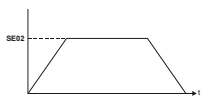
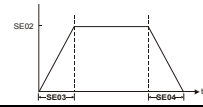
Refer to Figure 4-1 *Power connections for 480 V drive* on page 36 for minimum connections to get a motor running.



## 7.1 Quick start commissioning / start-up (from European defaults)

Action	Detail	
Before power-up	<p>Ensure:</p> <ul style="list-style-type: none"> <li>Drive Enable signal is not given (terminal 31)</li> <li>Run signal is not given</li> <li>Motor connected</li> <li>Tacho connected if one is being used</li> <li>Encoder connected if one is being used</li> </ul>	
Power-up the drive	<p>Ensure:</p> <ul style="list-style-type: none"> <li>Drive displays 'inh'</li> </ul> <p><b>NOTE</b></p> <p>The drive will trip 'th' (Motor thermistor trip) if no motor thermistor is connected to analog input 3 (terminal 8). If the motor protection is not connected to the drive, the 'th' trip can be disabled by setting Pr 7.15 (in01, 0.81) (analog input 3 mode) to VOLT.</p> <p>For drive trips, see Chapter 13 <i>Diagnostics</i> on page 181.</p>	
Enter motor nameplate details	<p>Enter:</p> <ul style="list-style-type: none"> <li>Armature rated voltage in Pr 5.09 (SE06, 0.27) (V)</li> <li>Motor rated current in Pr 5.07 (SE07, 0.28) (A)</li> <li>Motor rated speed (base speed) in Pr 5.08 (SE08, 0.29) (rpm)</li> <li>Field rated current in Pr 5.70 (SE10, 0.31) (A)</li> <li>Field rated voltage in Pr 5.73 (SE11, 0.32) (V)</li> </ul>	
Set motor feedback parameters	<p><b>Incremental encoder basic set-up</b></p> <p>Enter:</p> <ul style="list-style-type: none"> <li>Drive encoder type in Pr 3.38 (Fb07, 0.77) = Ab (0): Quadrature encoder</li> </ul> <div style="border: 1px solid black; padding: 5px;"> <p> Setting the encoder voltage supply too high for the encoder could result in damage to the feedback device.</p> <p><b>CAUTION</b></p> </div> <ul style="list-style-type: none"> <li>Encoder power supply in Pr 3.36 (Fb06, 0.76) = 5 V (0), 8 V (1), 15 V (2) or 24 V (3)</li> </ul> <p><b>NOTE</b></p> <p>If output voltage from the encoder is &gt;5 V, then the termination resistors must be disabled Pr 3.39 (Fb08, 0.78) to 0.</p> <ul style="list-style-type: none"> <li>Drive encoder lines per revolution (ELPR) in Pr 3.34 (Fb05, 0.75) (set according to encoder)</li> <li>Drive encoder termination resistor setting in Pr 3.39 (Fb08, 0.78) <ul style="list-style-type: none"> <li>0 = A-A\, B-B\, Z-Z\ termination resistors disabled</li> <li>1 = A-A\, B-B\, termination resistors enabled, Z-Z\ termination resistors disabled</li> <li>2 = A-A\, B-B\, Z-Z\ termination resistors enabled</li> </ul> </li> </ul> <p><b>Tachometer set-up</b></p> <p>Enter:</p> <ul style="list-style-type: none"> <li>Tachometer voltage rating Pr 3.51 (Fb02, 0.72) (V/1000 rpm)</li> <li>Tachometer input mode Pr 3.53 (Fb03, 0.73)</li> </ul>	
Set maximum speed	<p>Enter:</p> <ul style="list-style-type: none"> <li>Maximum speed in Pr 1.06 (SE02, 0.23) (rpm)</li> <li>Set Pr 5.64 = On If field weakening is required</li> </ul> <p><b>NOTE</b></p> <p>For field weakening in Estimated Speed Mode please refer to Chapter8 <i>Optimization</i> on page 85</p>	
Set acceleration / deceleration rates	<p>Enter:</p> <ul style="list-style-type: none"> <li>Acceleration rate in Pr 2.11 (SE03, 0.24) (time to accelerate to maximum speed)</li> <li>Deceleration rate in Pr 2.21 (SE04, 0.25) (time to decelerate from maximum speed)</li> </ul>	
Enable the field controller	<p><b>Field controller set-up</b></p> <ul style="list-style-type: none"> <li>Select field mode by setting Pr 5.78 = IntrnL (Internal field controller is used), Etrnl (External half control), E FULL (External in full control).</li> <li>Set Pr 5.77 (SE12, 0.33) = On to enable the field.</li> <li>Ensure that the L11-L12 connection is closed.</li> </ul>	

Action	Detail	
Static autotune	<p>Mentor MP is able to perform either a static, rotating or continuous autotune. The motor must be at a standstill before an autotune is enabled.</p> <p><b>Static autotune for current loop gains</b></p> <p>When this operation is performed the drive will perform an estimation of <i>Motor constant</i> (Pr 5.15), <i>Continuous proportional gain</i> (Pr 4.13), <i>Continuous integral gain</i> (Pr 4.14), <i>Discontinuous integral gain</i> (Pr 4.34), <i>Back EMF set point</i> (Pr 5.59), <i>Armature resistance</i> (Pr 5.61), <i>Flux loop P gain</i> (Pr 5.71) and <i>Flux loop I gain</i> (Pr 5.72) with respect to the selected motor map and store the values.</p> <p>To perform a static autotune:</p> <ul style="list-style-type: none"> <li>Set Pr 5.12 (SE13, 0.34) = 1</li> <li>Close the Drive Enable signal (terminal 31). The drive will display 'rdY'</li> <li>Close the run signal (terminal 26 or 27). The lower display will flash 'Auto' and 'tunE' alternatively, while the drive is performing the autotune</li> <li>Remove the enable signal when the autotune has finished</li> <li>Remove the run signal</li> </ul> <p>If a feedback device is used then it is recommended that a rotating autotune is performed in order to set up the field brake points and obtain a more accurate estimated speed value. Estimated speed value is compared with actual speed value and if the difference is more than the window specified by Pr 3.56 default 20 % the drive will trip FdL. If the application prohibits a rotating autotune then a manual attempt to set Pr 5.29, Pr 5.30 and Pr 5.74 should be made to optimize estimated speed value in order to prevent spurious FbL trips particularly during acceleration.</p>	
Checking speed feedback	<ul style="list-style-type: none"> <li>Close the enable signal. Close the run signal (terminal 26 or 27). Provide speed reference to run the drive up to a low speed, the drive will regulate its own estimated speed.</li> <li>Check that the feedback device is functioning correctly: <ul style="list-style-type: none"> <li>For encoder speed feedback - Check encoder speed feedback Pr 3.27 (Fb09, 0.79).</li> <li>For tachometer speed feedback - Check tachometer speed feedback Pr 3.52 (Fb04, 0.74).</li> </ul> </li> <li>When the feedback device being used is seen to be functioning correctly, stop the drive and select the correct feedback device using Pr 3.26 (Fb01, Pr 0.71)</li> </ul> <p><b>NOTE</b></p> <p>For improved estimated speed accuracy and torque control in the field weakening range a rotating autotune is recommended to determine the motor flux characteristics Pr 5.12 (SE13, 0.34) = 2</p>	
Rotating autotune	<p>Mentor MP is able to perform either a static, rotating or continuous autotune. The motor must be at a standstill and unloaded before a rotating autotune is enabled.</p> <p><b>NOTE</b></p> <p>A rotating autotune cannot be carried out in Estimated speed mode.</p> <div style="border: 1px solid black; padding: 5px; margin: 5px 0;">  <p>A rotating autotune will cause the motor to accelerate up to <math>\frac{1}{4}</math> base speed in the direction selected regardless of the reference provided. Once complete the motor will coast to a stop. The enable signal must be removed before the drive can be made to run at the required reference.</p> <p><b>WARNING</b> The drive can be stopped at any time by removing the run signal or removing the drive enable.</p> </div> <p><b>Rotating autotune for motor field flux set-up</b></p> <p>When selected the drive will determine the rated field compensation factor (Pr 5.74) for rated flux and the motor field winding saturation break-points (Pr 5.29 and Pr 5.30), by spinning the motor at 25 % of its base speed Pr 5.08 (SE08, 0.29) with respect to the selected motor map and store the values.</p> <p>To perform an autotune:</p> <ul style="list-style-type: none"> <li>Set Pr 5.12 (SE13, 0.34) = 2 for a rotating autotune</li> <li>Close the Drive Enable signal (terminal 31). The drive will display 'rdY'</li> <li>Close the run signal (terminal 26 or 27). The lower display will flash 'Auto' and 'tunE' alternatively, while the drive is performing the autotune</li> <li>Wait for the drive to display 'inh' and for the motor to come to a standstill</li> </ul> <p>If the drive trips, see Chapter 13 <i>Diagnostics</i> on page 181.</p> <ul style="list-style-type: none"> <li>Remove the drive enable and run signal from the drive.</li> </ul>	
Save parameters	<p>Select SAVE in Pr xx.00 (SE00, 0.21)</p> <p>Press the red  reset button or toggle the reset digital input (ensure Pr xx.00 (SE00, 0.21) returns to 'no Act').</p>	
Run	<p>Drive is now ready to run</p> <ul style="list-style-type: none"> <li>Close enable signal</li> <li>Close run signal</li> <li>Provide speed reference</li> </ul>	

## 7.2 Quick start commissioning / start-up (from USA defaults)

Action	Detail	
Before power-up	<p>Ensure:</p> <ul style="list-style-type: none"> <li>Drive Enable signal is not given (terminal 31)</li> <li>Run signal is not given</li> <li>Motor connected</li> <li>Tacho connected if one is being used</li> <li>Encoder connected if one is being used</li> </ul>	
Power-up the drive	<p>Ensure:</p> <ul style="list-style-type: none"> <li>Drive displays 'inh'</li> </ul> <p><b>NOTE</b> Motor thermistor input is disabled by default. If motor thermistor is available the thermistor should be used. The protection is enabled with Pr 7.15 (in01, 0.81). For drive trips, see Chapter 13 <i>Diagnostics</i> on page 181.</p>	
Enter motor nameplate details	<p>Enter:</p> <ul style="list-style-type: none"> <li>Armature rated voltage in Pr 5.09 (SE06, 0.27) (V)</li> <li>Motor rated current in Pr 5.07 (SE07, 0.28) (A)</li> <li>Motor rated speed (base speed) in Pr 5.08 (SE08, 0.29) (rpm)</li> <li>Field rated voltage in Pr 5.73 (SE11, 0.32) (V)</li> </ul>	
Set motor feedback parameters	<p><b>Incremental encoder basic set-up</b></p> <p>Enter:</p> <ul style="list-style-type: none"> <li>Drive encoder type in Pr 3.38 (Fb07, 0.77) = Ab (0): Quadrature encoder</li> </ul> <div style="border: 1px solid black; padding: 5px; margin: 10px 0;">  <p>Setting the encoder voltage supply too high for the encoder could result in damage to the feedback device.</p> <p><b>CAUTION</b></p> </div> <ul style="list-style-type: none"> <li>Encoder power supply in Pr 3.36 (Fb06, 0.76) = 5 V (0), 8 V (1), 15 V (2) or 24 V (3)</li> </ul> <p><b>NOTE</b> If output voltage from the encoder is &gt;5 V, then the termination resistors must be disabled Pr 3.39 (Fb08, 0.78) to 0.</p> <ul style="list-style-type: none"> <li>Drive encoder lines per revolution (ELPR) in Pr 3.34 (Fb05, 0.75) (set according to encoder)</li> <li>Drive encoder termination resistor setting in Pr 3.39 (Fb08, 0.78) <ul style="list-style-type: none"> <li>0 = A-A\, B-B\, Z-Z\ termination resistors disabled</li> <li>1 = A-A\, B-B\, termination resistors enabled, Z-Z\ termination resistors disabled</li> <li>2 = A-A\, B-B\, Z-Z\ termination resistors enabled</li> </ul> </li> </ul> <p><b>Tachometer set-up</b></p> <p>Enter:</p> <ul style="list-style-type: none"> <li>Tachometer voltage rating Pr 3.51 (Fb02, 0.72) (V/1000 rpm)</li> <li>Tachometer input mode Pr 3.53 (Fb03, 0.73)</li> </ul>	
Set maximum speed	<p>Enter:</p> <ul style="list-style-type: none"> <li>Maximum speed in Pr 1.06 (SE02, 0.23) (rpm)</li> </ul> <p><b>NOTE</b> For field weakening the field controller needs to be set-up in current control by setting Pr 5.75 = OFF, setting the rated field current into Pr 5.70 (SE10, 0.31) and setting Pr 5.64 to On. For field weakening in Estimated Speed Mode please refer to Chapter 8 <i>Optimization</i> on page 85.</p>	
Set acceleration / deceleration rates	<p>Enter:</p> <ul style="list-style-type: none"> <li>Acceleration rate in Pr 2.11 (SE03, 0.24) (time to accelerate to maximum speed)</li> <li>Deceleration rate in Pr 2.21 (SE04, 0.25) (time to decelerate from maximum speed)</li> </ul>	
Enable the field controller	<p><b>Field controller set-up</b></p> <ul style="list-style-type: none"> <li>Select field mode by setting Pr 5.78 = IntrnL (Internal field controller is used), Etrnl (External half control), E FULL (External in full control).</li> <li>Set Pr 5.77 (SE12, 0.33) = On to enable the field.</li> <li>Ensure that the L11-L12 connection is closed.</li> </ul>	

Action	Detail
Static autotune	<p>Mentor MP is able to perform either a static, rotating or continuous autotune. The motor must be at a standstill before an autotune is enabled.</p> <p><b>Static autotune for current loop gains</b></p> <p>When this operation is performed the drive will perform an estimation of <i>Motor constant</i> (Pr 5.15), <i>Continuous proportional gain</i> (Pr 4.13), <i>Continuous integral gain</i> (Pr 4.14), <i>Discontinuous integral gain</i> (Pr 4.34), <i>Back EMF set point</i> (Pr 5.59), <i>Armature resistance</i> (Pr 5.61), <i>Flux loop P gain</i> (Pr 5.71) and <i>Flux loop I gain</i> (Pr 5.72) with respect to the selected motor map and store the values.</p> <p>To perform a static autotune:</p> <ul style="list-style-type: none"> <li>Set Pr 5.12 (SE13, 0.34)= 1</li> <li>Close the Drive Enable signal (terminal 31). The drive will display 'rdY'</li> <li>Close the run signal (terminal 26 or 27). The lower display will flash 'Auto' and 'tunE' alternatively, while the drive is performing the autotune</li> <li>Remove the enable signal when the autotune has finished</li> <li>Remove the run signal</li> </ul> <p><b>NOTE</b></p> <p>A rotating autotune Pr 5.12 (SE13, 0.34) = 2 should not be carried out when the field controller is in voltage mode, Pr 5.75 = On (USA default).</p> <p>If a feedback device is used then it is recommended that a rotating autotune is performed in order to set up the field brake points and obtain a more accurate estimated speed value. Estimated speed value is compared with actual speed value and if the difference is more than the window specified by Pr 3.56 default 20 % the drive will trip FdL. If the application prohibits a rotating autotune then a manual attempt to set Pr 5.29, Pr 5.30 and Pr 5.74 should be made to optimize estimated speed value in order to prevent spurious FbL trips particularly during acceleration.</p>
Checking speed feedback	<ul style="list-style-type: none"> <li>Close the enable signal. Close the run signal (terminal 26 or 27). Provide speed reference to run the drive up to a low speed, the drive will regulate its own estimated speed.</li> <li>Check that the feedback device is functioning correctly: <ul style="list-style-type: none"> <li>For encoder speed feedback - Check encoder speed feedback Pr 3.27 (Fb09, 0.79).</li> <li>For tachometer speed feedback - Check tachometer speed feedback Pr 3.52 (Fb04, 0.74).</li> </ul> </li> <li>When the feedback device being used is seen to be functioning correctly, stop the drive and select the correct feedback device using Pr 3.26 (Fb01, Pr 0.71).</li> </ul>
Save parameters	<p>Select SAVE in Pr xx.00 (SE00, 0.21)</p> <p>Press the red  reset button or toggle the reset digital input (ensure Pr xx.00 (SE00, 0.21) returns to 'no Act').</p>
Run	<p>Drive is now ready to run</p> <ul style="list-style-type: none"> <li>Close enable signal</li> <li>Close run signal</li> <li>Provide speed reference</li> </ul> 

## 7.3 CTSoft software commissioning / start-up tool

CTSoft can be used for commissioning / start-up and monitoring, drive parameters can be uploaded, downloaded and compared, and simple or custom menu listings can be created. Drive menus can be displayed in standard list format or as live block diagrams. CTSoft includes a migration wizard that allows Mentor II parameters to be migrated to the Mentor MP. CTSoft is able to communicate with a single drive or a network.

CT Soft can be downloaded from the website [www.controltechniques.com](http://www.controltechniques.com) (file size approximately 100 MB).

### 7.3.1 CTSoft system requirements:

- Windows 7, 2000/XP/Vista. **Windows 95/98/98SE/ME/NT4 and Windows 2003 server are NOT supported**
- Internet Explorer V5.0 or later must be installed
- Minimum of 800x600 screen resolution with 256 colors. 1024x768 is recommended.
- 256 MB RAM
- Pentium IV 1000MHz or better recommended.
- Adobe Acrobat Reader 5.1 or later (for parameter help).
- Microsoft.Net Frameworks 2.0
- Note that you must have full administrator rights to install CTSoft.

## 7.4 Setting up a feedback device

This section shows more detailed information on parameter settings that must be made to each of the compatible encoder types with Mentor MP. For more information on the parameters listed here please refer to the *Mentor MP Advanced User Guide*.

### 7.4.1 Detailed feedback device commissioning/start-up information

Standard quadrature encoder with or without marker pulse		
Encoder type	Pr 3.38 (Fb07, 0.77)	Ab (0) Standard quadrature incremental encoder with or without marker pulse
Encoder power supply voltage	Pr 3.36 (Fb06, 0.76)	5 V (0), 8 V (1) or 15 V (2) or 24 V (3) <b>NOTE</b> If the voltage from the encoder is >5 V, then the termination resistors must be disabled Pr 3.39 (Fb08, 0.78) to 0
Encoder number of lines per revolution	Pr 3.34 (Fb05, 0.75)	Set to the number of lines per revolution of the encoder
Encoder marker mode	Pr 3.35	0 = The marker system operates in a conventional manner, 1 = the marker causes a full position reset.
Encoder termination selection	Pr 3.39 (Fb08, 0.78)	0 = A, B, Z termination resistors disabled, 1 = A, B termination resistors enabled and Z termination resistors disabled, 2 = A, B, Z termination resistors enabled
Encoder error detection level	Pr 3.40	0 = No wire break detect, 1 = Wire break detect on A and B (need termination enabled for 5 V signals), 2 = Wire break detect on A, B and Z (need termination enabled for 5 V signals)

Incremental encoder with frequency and direction, or forward reverse signals, with or without marker pulse		
Encoder type	Pr 3.38 (Fb07, 0.77)	Fd (2) Incremental encoder with frequency and direction outputs, with or without marker pulse, Fr (3) Incremental encoder with forward and reverse outputs, with or without marker pulse
Encoder power supply voltage	Pr 3.36 (Fb06, 0.76)	5 V (0), 8 V (1) or 15 V (2) or 24 V (3) <b>NOTE</b> If the voltage from the encoder is >5 V, then the termination resistors must be disabled Pr 3.39 (Fb08, 0.78) to 0
Encoder number of lines per revolution	Pr 3.34 (Fb05, 0.75)	Set to the number of lines per revolution of the encoder divide by 2
Encoder marker mode	Pr 3.35	0 = The marker system operates in a conventional manner, 1 = the marker causes a full position reset.
Encoder termination selection	Pr 3.39 (Fb08, 0.78)	0 = A, B, Z termination resistors disabled, 1 = A, B termination resistors enabled and Z termination resistors disabled, 2 = A, B, Z termination resistors enabled
Encoder error detection level	Pr 3.40	0 = No wire break detect, 1 = Wire break detect on A and B (need termination enabled for 5 V signals), 2 = Wire break detect on A, B and Z (need termination enabled for 5 V signals)



## 8 Optimization

Before attempting to tune the drive the following data is required

- Armature full load current
- Armature voltage
- Field current
- Field voltage
- Base speed
- Maximum speed

In the following worked example the data below has been used

- Armature full load current = 67 A with an overload of 90 A for up to 30 seconds
- Armature voltage = 500 V
- Field current = 1.85 A
- Field voltage = 300 V
- Base speed = 1750 rpm
- Maximum speed = 2500 rpm

### 8.1 Armature current

- Set the motor rated current in Pr **5.07 (SE07, 0.28)** to 67 A.
- Set current limits in Pr **4.05** and Pr **4.06** to  $90/67 \times 100 = 134\%$
- Set the motor thermal time constant in Pr **4.15** =  $-30 / \ln(1 - (1.05 / 1.34)^2) = 31.5$

### 8.2 Speed feedback

#### 8.2.1 Estimated speed feedback

For estimated speed feedback set Pr **3.26 (Fb01, 0.71)** to Est SPd. This uses an estimated speed feedback based on the motor back emf, motor rated speed, motor rated voltage, armature resistance, armature current and field flux feedback.

#### 8.2.2 Tachometer speed feedback

For tachometer speed feedback set Pr **3.26 (Fb01, 0.71)** to tACHO. Set the tachometer voltage rating in V/1000 rpm in Pr **3.51 (Fb02, 0.72)** and the tachometer input mode Pr **3.53 (Fb03, 0.73)** to suit the type of tachometer used.

#### 8.2.3 Encoder speed feedback

For encoder speed feedback set Pr **3.26 (Fb01, 0.71)** to drv. Set the lines per revolution (Pr **3.34 (Fb05, 0.75)**), encoder supply voltage (Pr **3.36 (Fb06, 0.76)**) and encoder type (Pr **3.38 (Fb07, 0.77)**).

#### 8.2.4 Solutions Module speed feedback

If an Solutions Module is being used to provide speed feedback then Pr **3.26 (Fb01, 0.71)** should be set to SLot1, SLot2, or SLot3.

### 8.3 Field current

The rated field current is set in Pr **5.70 (SE10, 0.31)**. When the field current equals the compensated rated field current (see Pr **5.74**), 100 % field flux is produced.

#### 8.3.1 Field weakening with a speed feedback device

If field weakening is required the field compensation factor (Pr **5.74**), the motor saturation breakpoints (Pr **5.29**, Pr **5.30**) and the voltage at which field weakening is required to begin (Pr **5.59**) must be set.

Setting up the drive in field weakening is straightforward when a speed feedback device is available. The rotating autotune (Pr **5.12 (SE13, 0.34)** = 2) automatically sets up the parameters above. Follow the quick start commissioning / start-up (from European defaults) as shown in Table 6-1 on page 70 to set up the drive. Enable field weakening (Pr **5.64** = On). Save parameters.

#### NOTE

For field weakening from USA defaults Pr **5.75 Field voltage mode** should be set to OFF. Pr **5.28 Field weakening compensation disable** should be set to OFF. Follow the quick start commissioning / start-up (from European defaults) as shown in Table 6-1 on page 70 to set up the drive. Enable field weakening (Pr **5.64** = On). Save parameters.

#### 8.3.2 Field weakening in estimated speed mode (no speed feedback device)

The Rotating Autotune (Pr **5.12 (SE13, 0.34)** = 2) sets up the field controller for more accurate flux control and open loop speed accuracy. The rotating autotune needs to know the motor speed and so a speed feedback device has to be connected to the drive before a rotating autotune can be carried out. In some applications a speed feedback device may not be required and so the procedure below allows the user to manually adjust the field controller parameters to achieve better open loop speed control.

- Follow the quick start commissioning / start-up (from European defaults) as shown in Table 6-1 *Pre-defined sub block parameters* on page 70 until a static autotune (Pr **5.12 (SE13, 0.34)** = 1) has been carried out.
- Set Pr **5.64 Field weakening enable** to On.
- Ensure that Pr **5.29**, Pr **5.30**, Pr **5.68** and Pr **5.74** are set to their default values of 50 %, 75 %, 100 % and 100 % respectively.
- Set the speed demand to 1/4 of *Base speed* (Pr **5.08 (SE08, 0.29)**) and run the machine up to speed and check the speed of the machine using a hand held device.
- If the machine speed is lower than 1/4 of base speed (which is normally the case) adjust the *Field compensation factor* (Pr **5.74**) down until the correct machine speed is reached. If the machine speed is higher than 1/4 of base speed (only possible if the motor nameplate field current is low), adjust the rated field current (Pr **5.70 (SE10, 0.31)**) up until the correct machine speed is reached.
- Set Pr **5.68 Maximum flux** to 75 % and measure the actual speed of the machine (speed 75)
- Set Pr **5.68 Maximum flux** to 50 % and measure the actual speed of the machine (speed 50).
- Stop the machine and set Pr **5.68 Maximum flux** back to 100 %.
- Set Pr **5.29 Motor saturation breakpoint 1** = 50 x set speed / actual speed (Speed 50)
- Set Pr **5.30 Motor saturation breakpoint 2** = 75 x set speed / actual speed (speed 75).
- Save parameters.

#### NOTE

For field weakening from USA defaults Pr **5.75 Field voltage mode** should be set to OFF. Pr **5.28 Field weakening compensation disable** should be set to OFF. The procedure above should then be followed to set up the drive for field weakening.

#### 8.3.3 Field economy

Field economy can be used to keep the field energized, at a low level of current (to prevent overheating), when the motor is not running to prevent condensation forming in the motor. The field economy level and the timeout can be adjusted.

To use this function it is necessary to set:

- Set Pr **5.65** to enable the field economy timeout
- Set Pr **5.67** to the percentage of full field that you want to use in economy mode e.g 10 %.
- Set Pr **5.66** to the time after the drive enable signal is removed to the field current reducing to the economy level.

### 8.4 Current loop gains self-tuning

For optimum performance the current loop must be set-up. The dynamics of the current loop are principally a function of the electrical characteristics of a particular motor.

The drive determines the electrical characteristics of the motor by injecting current into the armature winding.

#### 8.4.1 Static autotune for current loop gains

If Pr **5.12 (SE13, 0.34)** is set to a 1, when the drive is enabled and a run command is applied in either direction the drive performs a static autotune test. The test will not start unless the drive is disabled before the test is initiated. i.e. autotune will not start unless the drive is in a stop state.

When this operation is performed the drive will determine the *Motor constant* (Pr 5.15), *Continuous proportional gain* (Pr 4.13), *Continuous integral gain* (Pr 4.14), *Discontinuous integral gain* (Pr 4.34), *Back EMF set point* (Pr 5.59), *Armature resistance* (Pr 5.60) and *Flux loop I gain* (Pr 5.72) with respect to the selected motor map and store the values.

### 8.4.2 Continuous autotune for current loop gains

In the static autotune the armature current loop gains are set up with no flux in the motor. In some motors the inductance of the armature changes significantly when flux is present in the machine. If this is the case, a continuous autotune can be enabled to correct the gains for the fluxed machine.

When Pr 5.26 is set to On, the continuous autotune is enabled which continuously monitors the motor ripple and adjusts *Motor constant* (Pr 5.15), *Continuous proportional gain* (Pr 4.13) and *Discontinuous integral gain* (Pr 4.34) for optimum performance.

The static autotune should still be carried out because *Continuous integral gain* (Pr 4.14) is not set by the continuous autotune.

Calculation of the gains is suspended when the voltage field weakening loop becomes active so that the gains are not increased when the field is weakened (less flux in the machine).

This function does not operate when the drives are set-up in serial 12 pulse.

### 8.4.3 Drive commissioning output

The Mentor MP has a test pin that gives instantaneous armature current feedback. The pin is identified by a half sign wave symbol and is located to the right of the tachometer terminals. An oscilloscope probe can be attached to this pin to monitor the armature current.

## 8.5 Speed loop gains tuning

The speed loop gains control the response of the speed controller to a change in speed demand. The speed controller includes proportional (Kp) and integral (Ki) feed forward terms, and a differential (Kd) feedback term. The drive holds two sets of these gains and either set may be selected for use by the speed controller with Pr 3.16

Pr 3.16 may be changed when the drive is enabled or disabled.

- If Pr 3.16 = 0 - gains Kp1, Ki1 and Kd1 are used
- If Pr 3.16 = 1 - gains Kp2, Ki2 and Kd2 are used

### 8.5.1 Proportional gain (Kp) Pr 3.10 (SP01, 0.61) and Pr 3.13

If Kp has a value and the integral gain Ki is set to zero the controller will only have a proportional term, and there must be a speed error to produce a torque reference. Therefore as the motor load increases there will be a difference between the reference and actual speeds.

This effect, called regulation, depends on the level of the proportional gain, the higher the gain the smaller the speed error for a given load.

If the proportional gain is too high either the acoustic noise produced by speed feedback quantization becomes unacceptable, or the stability limit is reached.

### 8.5.2 Integral gain (Ki) Pr 3.11 (SP02, 0.62) and Pr 3.14

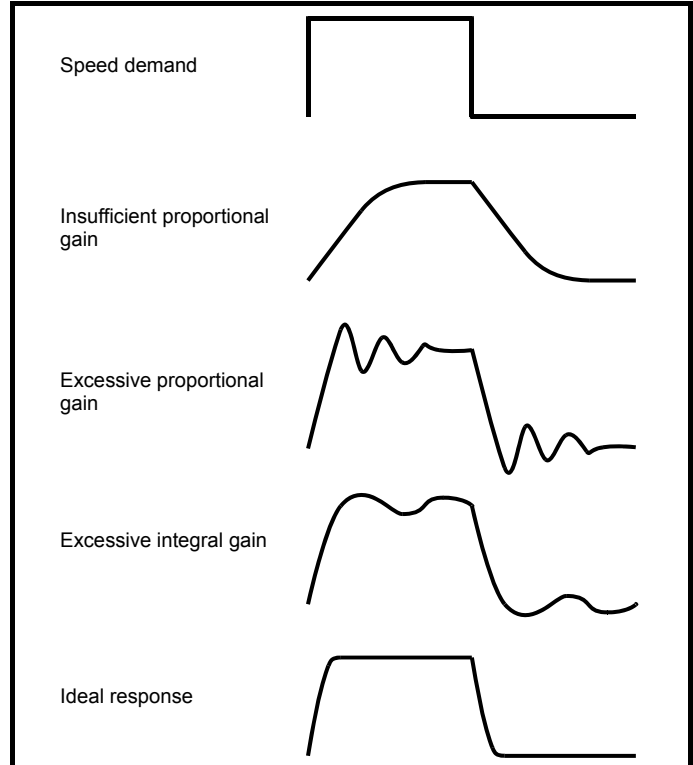
The integral gain is provided to prevent speed regulation. The error is accumulated over a period of time and used to produce the necessary torque demand without any speed error. Increasing the integral gain reduces the time taken for the speed to reach the correct level and increases the stiffness of the system, i.e. it reduces the positional displacement produced by applying a load torque to the motor. Unfortunately increasing the integral gain also reduces the system damping giving overshoot after a transient. For a given integral gain the damping can be improved by increasing the proportional gain. A compromise must be reached where the system response, stiffness and damping are all adequate for the application. The term is implemented in the form of  $\Sigma(Ki \times \text{error})$ , and so the integral gain can be changed when the controller is active without causing large torque demand transients.

### 8.5.3 Differential gain (Kd) Pr 3.12 (SP03, 0.63) and Pr 3.15

The differential gain is provided in the feedback of the speed controller to give additional damping. The differential term is implemented in a way that does not introduce excessive noise normally associated with this type of function. Increasing the differential term reduces the overshoot produced by under-damping, however, for most applications the proportional and integral gains alone are sufficient.

### 8.5.4 Manually setting up the speed loop gains

Figure 8-1 Responses



There are two methods of tuning the speed loop gains dependant on the setting of Pr 3.17:

#### 1. Pr 3.17 = 0, User set-up.

This involves the connecting of an oscilloscope to analog output 1 to monitor the speed feedback. Give the drive a step change in speed reference and monitor the response of the drive on the oscilloscope.

The proportional gain (Kp) should be set up initially. The value should be increased up to the point where the speed overshoots and then reduced slightly.

The integral gain (Ki) should then be increased up to the point where the speed becomes unstable and then reduced slightly.

It may now be possible to increase the proportional gain to a higher value and the process should be repeated until the system response matches the ideal response as shown.

Figure 8-1 shows the effect of incorrect P and I gain settings as well as the ideal response.

#### 2. Pr 3.17 = 1, Bandwidth set-up

If bandwidth based set-up is required, the drive can calculate Kp and Ki if the following parameters are set up correctly:

Pr 3.18 - Motor and load inertia - it is possible to measure the load inertia as part of the auto-tuning process (see Pr 5.12 (SE13, 0.34)).

Pr 3.20 - Required bandwidth,

Pr 3.21 - Required damping factor,

Pr 5.32 - Motor torque per amp (Kt).

### 8.5.5 Speed loop gains for very high inertia

Pr 3.17 = 2 - Kp gain times 16

If this parameter is set to 2 the Kp gain (from whichever source), is multiplied by 16. This is intended to boost the range of Kp for applications with very high inertia. It should be noted that if high values of Kp are used it is likely that the speed controller output will need to be filtered, see (Pr 3.42). If the feedback is not filtered it is possible that the output of the speed controller will be a square wave that changes between the current limits causing the integral term saturation system to malfunction.

### 8.6 Current limit tapers

With some motors the commutation limit of the motor requires that the maximum armature current be reduced at higher speeds, the current limit tapers can be used to provide this speed dependent current limit.

For more information refer to the *Mentor MP Advanced User Guide*.

# 9 SMARTCARD operation

## 9.1 Introduction

This is a standard feature that enables simple configuration of parameters in a variety of ways. The SMARTCARD can be used for:

- Parameter copying between drives
- Saving whole drive parameter sets
- Saving 'differences from default' parameter sets
- Storing Onboard PLC programs
- Automatically saving all user parameter changes for maintenance purposes
- Loading complete motor map parameters.

Refer to Figure 9-1 for installing the SMARTCARD. Ensure the SMARTCARD is inserted with the MP arrow pointing upwards.

The drive only communicates with the SMARTCARD when commanded to read or write, this means that the card may be 'hot swapped'.

The whole card may be protected from writing or erasing by setting the read-only flag as shown in section 9.3.9 9888 / 9777 - *Set / clear the SMARTCARD read only flag* on page 90.

Either of these indications will tell the user that data is being transferred to or from the SMARTCARD:

- SM-Keypad: The decimal point after the fourth digit in the upper display will flash.
- MP-Keypad: The symbol 'CC' will appear in the lower left hand corner of the display.

The card should not be removed during data transfer because the drive will trip. If a trip occurs you must either try to transfer the data again or, in the case of a card-to-drive transfer, the default parameters should be loaded.

## 9.3 Transferring data

When a code is entered into Pr **xx.00** and the drive is subsequently reset, the drive will carry out the actions listed in Table 9-2.

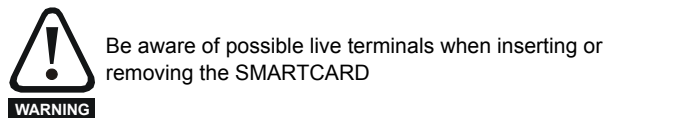
**Table 9-2 Transferring data**

Codes	Actions
Pr <b>x.00</b> = rAd 1	Transfer SMARTCARD data block 1 to the drive.
Pr <b>x.00</b> = rAd 2	Transfer SMARTCARD data block 2 to the drive.
Pr <b>x.00</b> = rAd 3	Transfer SMARTCARD data block 3 to the drive.
Pr <b>x.00</b> = PrOg 1	Transfer drive parameters as difference from default to SMARTCARD data block number 1.
Pr <b>x.00</b> = PrOg 2	Transfer drive parameters as difference from default to SMARTCARD data block number 2.
Pr <b>x.00</b> = PrOg 3	Transfer drive parameters as difference from default to SMARTCARD data block number 3.
Pr <b>x.00</b> = 2001	Transfer drive parameters as difference from defaults to a bootable SMARTCARD data block with block number 1. This will clear data block 1 on the card if it already exists.
Pr <b>x.00</b> = 3yyy	Transfer drive parameters to a SMARTCARD data block number yyy.
Pr <b>x.00</b> = 4yyy	Transfer drive data as difference from defaults to SMARTCARD data block number yyy.
Pr <b>x.00</b> = 5yyy	Transfer drive user program to SMARTCARD data block number yyy.
Pr <b>x.00</b> = 6yyy	Transfer SMARTCARD data block yyy to the drive.
Pr <b>x.00</b> = 7yyy	Erase SMARTCARD data block yyy.
Pr <b>x.00</b> = 8yyy	Compare drive parameters with data block yyy.
Pr <b>x.00</b> = 9555	Clear SMARTCARD warning suppression flag.
Pr <b>x.00</b> = 9666	Set SMARTCARD warning suppression flag.
Pr <b>x.00</b> = 9777	Clear SMARTCARD read-only flag.
Pr <b>x.00</b> = 9888	Set SMARTCARD read-only flag.
Pr <b>x.00</b> = 9999	Erase SMARTCARD.
Pr <b>11.42 (SE09, 0.30)</b> = Read	Transfer SMARTCARD data block 1 to the drive provided it is a parameter file.
Pr <b>11.42 (SE09, 0.30)</b> = Prog	Transfer drive parameters to a SMARTCARD data block number 1.
Pr <b>11.42 (SE09, 0.30)</b> = Auto	Transfer drive parameters to a SMARTCARD data block with data block number 1 provided.
Pr <b>11.42 (SE09, 0.30)</b> = boot	Pr <b>11.42 (SE09, 0.30)</b> has been changed since power-up.

Where yyy indicates the data block number 001 to 999, refer to Table 9-1 for restrictions on data block numbers.

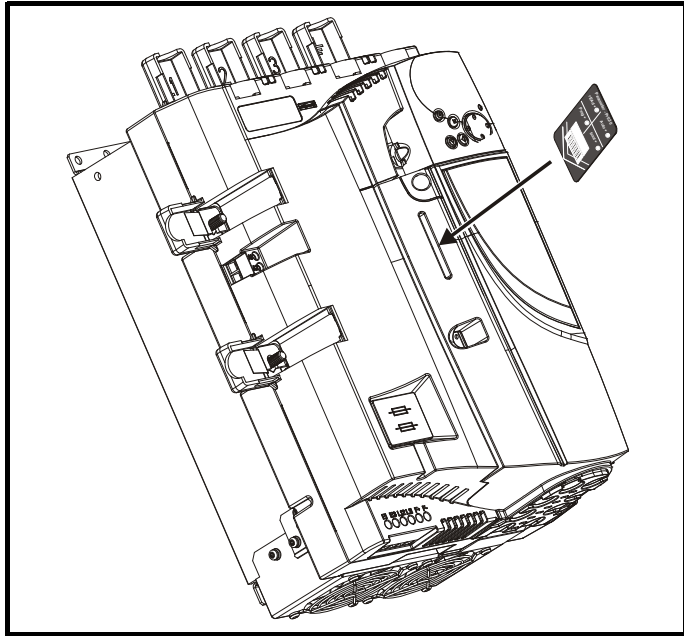
**NOTE**

If the read only flag is set then only codes 6yyy or 9777 are effective.



Be aware of possible live terminals when inserting or removing the SMARTCARD

**Figure 9-1 Installation of the SMARTCARD**



## 9.2 Easy saving and reading

The SMARTCARD has 999 individual data block locations. Each individual location from 1 to 499 can be used to store data.

The drive can support SMARTCARDS that have a capacity of between 4 kB and 512 kB.

The usage of the data block locations in the SMARTCARD are shown in Table 9-1.

**Table 9-1 SMARTCARD data blocks**

Data block	Type	Example of usage
1 to 499	Read / Write	Application set-up
500 to 999	Read Only	Macros

Parameter sets labelled as 'Differences from default' will be much smaller than whole parameter sets. Therefore they use a lot less memory because most applications only require a few parameters to be changed from the default setting.

### 9.3.1 Writing to the SMARTCARD

#### 3yyy - Transfer data to the SMARTCARD

The data block contains the complete parameter data from the drive, i.e. all user-save (US) parameters except parameters with the NC coding bit set. Power-down save (PS) parameters are not transferred to the SMARTCARD.

#### 4yyy - Write default differences to a SMARTCARD

The data block only contains the parameter differences from the last time default settings were loaded.

Six bytes are required for each parameter difference. The data density is not as high as when using the 3yyy transfer method as described in the section *3yyy - Transfer data to the SMARTCARD* but in most cases the number of differences from default is small and the data blocks are therefore smaller. This method can be used for creating drive macros. PS parameters are not transferred to the SMARTCARD.

#### Writing a parameter set to the SMARTCARD

Setting Pr 11.42 (SE09, 0.30) to Prog (2) and resetting the drive will save the parameters to the SMARTCARD, i.e. this is equivalent to writing 3001 to Pr xx.00. All SMARTCARD trips apply except 'C.Chg'. If the data block already exists it is automatically overwritten.

When the action is complete this parameter is automatically reset to nonE (0).

### 9.3.2 Reading from the SMARTCARD

#### 6yyy - Read default differences from a SMARTCARD

When the data is transferred back to a drive, using 6yyy in Pr xx.00, it is transferred to the drive RAM and the drive EEPROM. A parameter save is not required to retain the data after power-down. Set-up data for any Solutions Modules installed are stored on the card and are transferred to the destination drive. If the Solutions Modules are different between the source and destination drive, the menus for the slots where the Solutions Module categories are different are not updated from the card and will contain their default values after the copying action.

The drive will produce a 'C.Optn' trip if the Solutions Modules installed to the source and destination drive are different or are in different slots. If the data is being transferred to a drive of a different voltage or current rating a 'C.rtg' trip will occur.

Table 9-3 lists the rating dependent parameters (RA coding bit set) that will not be written to the destination drive and will contain their default values after the copying action.

**Table 9-3 Rating dependent parameters**

Parameter	Function
4.05	Current limit
4.06	Current limit
4.07	Current limit
4.24	User current maximum scaling
5.07 (SE07, 0.28)	Motor rated current
5.09 (SE06, 0.27)	Armature rated voltage

#### Reading a parameter set from the SMARTCARD

Setting Pr 11.42 (SE09, 0.30) to rEAd (1) and resetting the drive will transfer the parameters from the card into the drive parameter set and the drive EEPROM, i.e. this is equivalent to writing 6001 to Pr xx.00. All SMARTCARD trips apply. Once the parameters are successfully copied this parameter is automatically reset to nonE (0). Parameters are saved to the drive EEPROM after this action is complete.

#### NOTE

This operation is only performed if data block 1 on the card is a full parameter set (3yyy transfer) and not a default difference file (4yyy transfer). If data block 1 does not exist a 'C.dAt' trip occurs.

### 9.3.3 Auto saving parameter changes

This setting causes the drive to automatically save any changes made to Menu 0 parameters on the drive to the SMARTCARD. The latest Menu 0 parameter set in the drive is therefore always backed up on the SMARTCARD.

Changing Pr 11.42 (SE09, 0.30) to Auto (3) and resetting the drive will immediately save the complete parameter set from the drive to the card, i.e. all User Save (US) parameters except parameters with the NC coding bit set. Once the whole parameter set is stored only the individual modified menu 0 parameter setting is updated.

Advanced parameter changes are only saved to the card when Pr xx.00 is set to a 1000 and the drive reset.

All SMARTCARD trips apply, except 'C.Chg'. If the data block already contains information it is automatically overwritten.

If the card is removed when Pr 11.42 (SE09, 0.30) is set to 3, Pr 11.42 (SE09, 0.30) is then automatically set to nonE (0).

When a new SMARTCARD is installed Pr 11.42 (SE09, 0.30) must be set back to Auto (3) by the user and the drive reset so the complete parameter set is rewritten to the new SMARTCARD if auto mode is still required.

When Pr 11.42 (SE09, 0.30) is set to Auto (3) and the parameters in the drive are saved, the SMARTCARD is also updated, therefore the SMARTCARD becomes a copy of the drives stored configuration.

At power up, if Pr 11.42 (SE09, 0.30) is set to Auto (3), the drive will save the complete parameter set to the SMARTCARD. The drive will display 'cArd' during this operation. This is done to ensure that if a user puts a new SMARTCARD in during power down the new SMARTCARD will have the correct data.

#### NOTE

When Pr 11.42 (SE09, 0.30) is set to Auto (3) the setting of Pr 11.42 (SE09, 0.30) itself is saved to the drive EEPROM but NOT to the SMARTCARD.

### 9.3.4 Booting up from the SMARTCARD on every power up (Pr 11.42 (SE09, 0.30) = boot (4))

When Pr 11.42 (SE09, 0.30) is set to boot (4) the drive operates the same as Auto mode, except when the drive is powered up. The parameters on the SMARTCARD will be automatically transferred to the drive at power-up if the following are true:

- A card is inserted in the drive
- Parameter data block 1 exists on the card
- The data in block 1 is type 1 to 5 (as defined in Pr 11.38)
- Pr 11.42 (SE09, 0.30) on the card set to boot (4)

The drive will display 'boot' during this operation. If the drive mode is different from that on the card, the drive gives a 'C.Typ' trip and the data is not transferred.

If 'boot' mode is stored on the copying SMARTCARD this makes the copying SMARTCARD the master device. This provides a very fast and efficient way of re-programming a number of drives.

If data block 1 contains a bootable parameter set and data block 2 contains an Onboard PLC program (type 17 as defined in Pr 11.38), then the onboard PLC program will be transferred to the drive at power up along with the parameter set in data block 1.

#### NOTE

"Boot" mode is saved to the card, but when the card is read, the value of Pr 11.42 (SE09, 0.30) is not transferred to the drive.

### 9.3.5 Booting up from the SMARTCARD on every power up (Pr xx.00 = 2001)

It is possible to create a difference from default bootable file by setting Pr xx.00 to 2001 and resetting the drive. This type of file causes the drive to behave in the same way at power-up as a file created with boot mode set up with Pr 11.42 (SE09, 0.30). The difference from the default file is that it has the added advantage of including Menu 20 parameters.

Setting Pr xx.00 to 2001 will overwrite data block 1 on the card, if it already exists.

If a data block 2 exists and contains an Onboard PLC program (type 17 as defined in Pr 11.38), this will also be loaded after the parameters have been transferred.

A bootable difference from default file can only be created in one operation and parameters cannot be added as they are saved via Menu 0.

### 9.3.6 Comparing drive full parameter set with the SMARTCARD values

Setting 8yyy in Pr **xx.00**, will compare the SMARTCARD file with the data in the drive:

- If the compare is successful Pr **xx.00** is simply set to 0
- If the compare fails a 'C.cpr' trip is initiated

### 9.3.7 7yyy / 9999 - Erasing data from the SMARTCARD

Data can be erased from the SMARTCARD one data block at a time or with data blocks 1 to 499 in selected together.

- Setting 7yyy in Pr **xx.00** will erase SMARTCARD data block yyy
- Setting 9999 in Pr **xx.00** will erase SMARTCARD data blocks 1 to 499

### 9.3.8 9666 / 9555 - Set / clear SMARTCARD warning suppression flag

1. If the Solutions Module(s) installed to the source and destination drive are different, or are in different slots, the drive will produce a 'C.Optr' trip.
2. If the data is being transferred to a drive of a different voltage or current rating a 'C.rtg' trip will occur.

It is possible to suppress these trips by setting the warning suppression flag. If this flag is set the drive will not trip if the Solutions Module(s) or drive ratings are different between the source and the destination drives. The Solutions Module or rating dependent parameters will not be transferred.

- Setting 9666 in Pr **xx.00** will set the warning suppression flag
- Setting 9555 in Pr **xx.00** will clear the warning suppression flag

### 9.3.9 9888 / 9777 - Set / clear the SMARTCARD read only flag

The SMARTCARD may be protected from writing or erasing by setting the read only flag. If an attempt is made to write or erase a data block when the read only flag is set, a 'C.Rdo' trip is initiated.

When the read only flag is set only codes 6yyy or 9777 are effective.

- Setting 9888 in Pr **xx.00** will set the read only flag
- Setting 9777 in Pr **xx.00** will clear the read only flag

## 9.4 Data block header information

Each data block stored on a SMARTCARD has header information detailing the following:

- A number which identifies the data block (Pr **11.37**)
- Type of data stored in the data block (Pr **11.38**)
- Drive mode if the data is parameter data (Pr **11.38**)
- Version number (Pr **11.39**)
- Checksum (Pr **11.40**)
- Read-only flag
- Warning suppression flag

The header information for each data block that has been used can be viewed in Pr **11.38** to Pr **11.40** by increasing or decreasing the data block number set in Pr **11.37**.

If Pr **11.37** is set to 1000: the checksum parameter (Pr **11.40**) shows the number of bytes left on the card in 16 byte pages.

If Pr **11.37** is set to 1001: the checksum parameter (Pr **11.40**) shows the total capacity of the card in 16 byte pages. Therefore, for a 4kB card this parameter would show 254.

If Pr **11.37** is set to 1002: the checksum parameter (Pr **11.40**) shows the state of the read-only (bit 0) and warning suppression flags (bit 1).

If there is no data on the card: Pr **11.37** can only have values of 0 or 1000 to 1002.

## 9.5 SMARTCARD parameters

11.36		SMARTCARD parameter data previously loaded											
RO	Uni	NC								PT	US		
↕	0 to 999							⇒	0				

This parameter shows the number of the data block last parameter or difference from default data block transferred from a SMARTCARD to the drive.

11.37		SMARTCARD data number											
RW	Uni	NC											
↕	0 to 1002							⇒	0				

This parameter shows the data blocks that are stored on a SMARTCARD with header information, including a number to identify the data block.

11.38		SMARTCARD data type/mode											
RO	Txt	NC								PT			
↕	0 to 18							⇒					

This parameter gives the type/mode of the data block selected with Pr **11.37** as shown in the following table.

Table 9-4 Pr 11.38 types and modes

Pr 11.38	String	Type/Mode
0	FrEE	Value when Pr <b>11.37</b> = 0
1	3C.SE	Commander SE mode parameter file (not used)
2	3OpEn.LP	Open-loop mode parameter file
3	3CL.VEct	Closed-loop vector mode parameter file
4	3SErVO	Servo mode parameter file
5	3REGEn	Regen mode parameter file
6	3DC	DC mode parameter file
7	3Un	Unused
8	3Un	Unused
9	4C.SE	Commander SE mode difference from default file (not used)
10	4OpEn.LP	Open-loop mode difference from default file
11	4CL.VEct	Closed-loop vector mode difference from default file
12	4SErVO	Servo mode difference from default file
13	4REGEn	Regen mode difference from default file
14	4DC	DC Mode difference from default file
15 & 16	4Un	Unused
17	LAddEr	Onboard Application Lite user program file
18	Option	A file containing user defined data (the file is normally created by an SM-Applications Solutions Module)
19	OptPrg	A file containing user defined data (normally created by an SM-Applications Solutions Module user program (Digitax ST only)

11.39		SMARTCARD data version											
RW	Uni	NC											
↕	0 to 9999							⇒	0				

This parameter gives the version number of the data block.

<b>11.40</b>		<b>SMARTCARD data checksum</b>											
RO	Uni	NC										PT	
↕	0 to 65335						⇒	0					

This parameter gives the checksum of the data block, space left on the card, the total space on the card or the card flags. Refer to Pr 11.37 for information.

<b>11.42</b>		<b>Parameter copying</b>											
<b>(SE09, 0.30)</b>													US*
RW	Txt	NC											
↕	0 to 4						⇒	0					

\* Mode 1 and Mode 2 are not saved when the drive parameters are saved. This parameter can only be saved to EEPROM if it has a value of 0, 3 or 4.

**Table 9-5 Pr 11.42 actions**

Actions	Value	Result
None	0	Inactive
Reading	1	Read parameter set from SMARTCARD
Programming	2	Program parameter set to the SMARTCARD
Auto	3	Auto save
Boot	4	Boot mode

**NOTE**

## 9.6 SMARTCARD trips

After an attempt to read, write or erase data to or from a SMARTCARD a trip may occur if there has been a problem with the command. Table 9-6 lists the trip indications and conditions that will cause the SMARTCARD to trip,

**Table 9-6 Trip conditions**

Trip	Condition
<b>C.boot</b>	<b>SMARTCARD trip: The menu 0 parameter modification cannot be saved to the SMARTCARD because the necessary file has not been created on the SMARTCARD</b>
177	A write to a Menu 0 parameter has been initiated with the keypad by exiting edit mode and Pr 11.42 (SE09, 0.30) is set for auto or boot mode. However the necessary boot file has not been created on the SMARTCARD to take the new parameter value. This occurs when Pr 11.42 (SE09, 0.30) is changed to auto or boot mode, but the drive is not subsequently reset.
<b>C.BUSy</b>	<b>SMARTCARD trip: SMARTCARD can not perform the required function as it is being accessed by a Solutions Module</b>
178	An attempt has been made to access a SMARTCARD. However an Solutions Module is already accessing the SMARTCARD.
<b>C.Chg</b>	<b>SMARTCARD trip: Data location already contains data</b>
179	An attempt has been made to store data in a SMARTCARD data block that already exists.
<b>C.Optn</b>	<b>SMARTCARD trip: Solutions Modules installed are different between source drive and destination drive</b>
180	Parameter data or default difference data is being transferred from a SMARTCARD to the drive, but the Solutions Module categories are different between source and destination drives. This trip does not stop the data transfer, but is a warning that the data for the Solutions Modules that are different will be set to the default values and not the values from the card. This trip also applies if a compare is attempted between the data block and the drive.
<b>C.Rdo</b>	<b>SMARTCARD trip: SMARTCARD has the Read Only bit set</b>
181	An attempt has been made to modify a read-only SMARTCARD (i.e. erase the card, erase a file or create a file). A SMARTCARD is read-only if the read-only flag has been set or the card contains data blocks with numbers from 500 to 999. Attempting to create data blocks with numbers from 500 to 999 will always cause a trip.
<b>C.Err</b>	<b>SMARTCARD trip: SMARTCARD data is corrupted</b>
182	An attempt has been made to transfer a data block from a SMARTCARD to the drive or to compare a SMARTCARD data block and the checksum is incorrect or the data structure on the card is incorrect.
<b>C.dat</b>	<b>SMARTCARD trip: Data location specified does not contain any data</b>
183	An attempt has been made to transfer a data block from a SMARTCARD to the drive or to compare a SMARTCARD data block and the block does not exist.
<b>C.FULL</b>	<b>SMARTCARD trip: SMARTCARD full</b>
184	An attempt has been made to create a data block on a SMARTCARD, but there is not enough space on the card.
<b>C.Acc</b>	<b>SMARTCARD trip: SMARTCARD Read / Write fail</b>
185	An attempt has been made to access a SMARTCARD, but a card is not present or communications failure has occurred between the drive and the card. This trip is also produced if an attempt is made to access a data block that has already been opened by an Solutions Module.
<b>C.rtg</b>	<b>SMARTCARD trip: The voltage and/or current rating of the source and destination drives are different</b>
186	Parameter data or default difference data is being transferred from a SMARTCARD to the drive, but the current and /or voltage ratings are different between source and destination drives. This trip does not stop the data transfer, but is a warning that the data for the Solutions Modules that are different will be set to the default values and not the values from the card. This trip also applies if a compare is attempted between the data block and the drive.

Trip	Condition
<b>C.Typ</b>	<b>SMARTCARD trip: SMARTCARD parameter set not compatible with drive</b>
187	This trip is produced during a compare if the drive mode in the data block is different from the current drive mode and the file is a parameter or defaults differences file. This trip is also produced if an attempt is made to transfer parameters from a parameter or default difference to the drive if the drive mode in the data block is outside the allowed range of drive modes for the drive.
<b>C.cpr</b>	<b>SMARTCARD trip: The values stored in the drive and the values in the data block on the SMARTCARD are different</b>
188	A compare has been carried out between a data block on a SMARTCARD and the drive and the compare has failed. This trip only occurs if the compare has not already failed with the following trips: C.Typ, C.rtg, C.Optn, C.BUSy, C.Acc or C.Err.

**Table 9-7 SMARTCARD status indications**

Lower display	Description
<b>boot</b>	A parameter set is being transferred from the SMARTCARD to the drive during power-up. For further information please refer to <i>section 9.3.4 Booting up from the SMARTCARD on every power up (Pr 11.42 (SE09, 0.30) = boot (4))</i> on page 89.
<b>cArd</b>	The drive is writing a parameter set to the SMARTCARD during power-up. For further information please refer to <i>section 9.3.3 Auto saving parameter changes</i> on page 89.



## 10 Onboard PLC

### 10.1 Onboard PLC and SYPT Lite

The Mentor MP has the ability to store and execute a 6 kB Onboard PLC ladder logic program without the need for additional hardware in the form of a Solutions Module.

The ladder logic program is written using SYPT Lite, a Windows™ based ladder diagram editor allowing the development of programs for execution in SM-Applications Plus.

Advantages of SYPT Lite:

- SYPT Lite is designed to be easy to use and to make SYPT program development as simple as possible. The features provided are a sub-set of those in the SYPT program editor.
- SYPT Lite programs are developed using ladder logic, a graphical language widely used to program PLCs (IEC 61131-3).
- SYPT Lite allows the user to draw a ladder diagram representing a program.
- SYPT Lite provides a complete environment for the development of ladder diagrams. Ladder diagrams can be created, compiled into user programs and downloaded to SM-Applications Plus for execution, via the RJ45 serial communications port on the front of the drive.
- The run-time operation of the compiled ladder diagram on the target can also be monitored using SYPT Lite and facilities are provided to interact with the program on the target by setting new values for target parameters.
- SYPT Lite is available to download at: [www.controltechniques.com](http://www.controltechniques.com).

### 10.2 Benefits

The combination of the Onboard PLC and SYPT Lite means that Mentor MP can replace nano and some micro PLCs in many applications. The Onboard PLC programs can consist of up to a maximum of 50 ladder logic rungs (up to 7 function blocks and 10 contacts per rung). The Onboard PLC program can also be transferred to and from a SMARTCARD for backup or quick commissioning / start-up.

In addition to the basic ladder symbols, SYPT Lite contains a sub-set of the function from the full version of SYPT. These include:

- Arithmetic blocks
- Comparison blocks
- Timers
- Counters
- Multiplexers
- Latches
- Bit manipulation

Typical applications for the Onboard PLC include,

- Ancillary pumps
- Fans and control valves
- Interlocking logic
- Sequences routines
- Custom control words.

### 10.3 Limitations

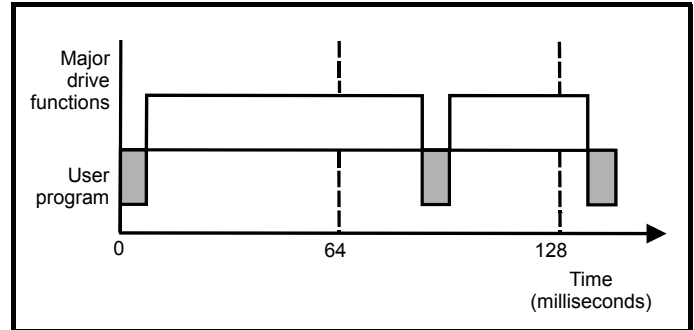
Compared with the SM-Applications Plus or SM-Applications Lite V2 modules when programmed with SYPT, the Onboard PLC program has the following limitations:

- The maximum program size is 6080 bytes including header and optional source code.
- The Mentor MP is rated for 100 program downloads. This limitation is imposed by the flash memory used to store the program within the drive.
- The user cannot create user variables. The user is only able to manipulate the drive parameter set.
- The program cannot be downloaded or monitored over CTNet. The program is only accessible via the drives RJ45 serial communications port.

- There are no real-time tasks, i.e. the scheduling rate of the program cannot be guaranteed. SM-Applications Plus tasks such as Clock, Event, Pos0 or Speed are not available.
- The Onboard PLC should not be used for time-critical applications. For time-critical applications either the SM-Applications Plus or SM-Applications Lite V2 Solutions Modules should be used.

The program runs at a low priority. The Mentor MP provides a single background task in which to run a ladder diagram. The drive is prioritized to perform its major functions first, e.g. motor control, and will use any remaining processing time to execute the ladder diagram as a background activity. As the drive's processor becomes more heavily loaded, less time is spent executing the program.

**Figure 10-1 Mentor MP Onboard PLC program scheduling**



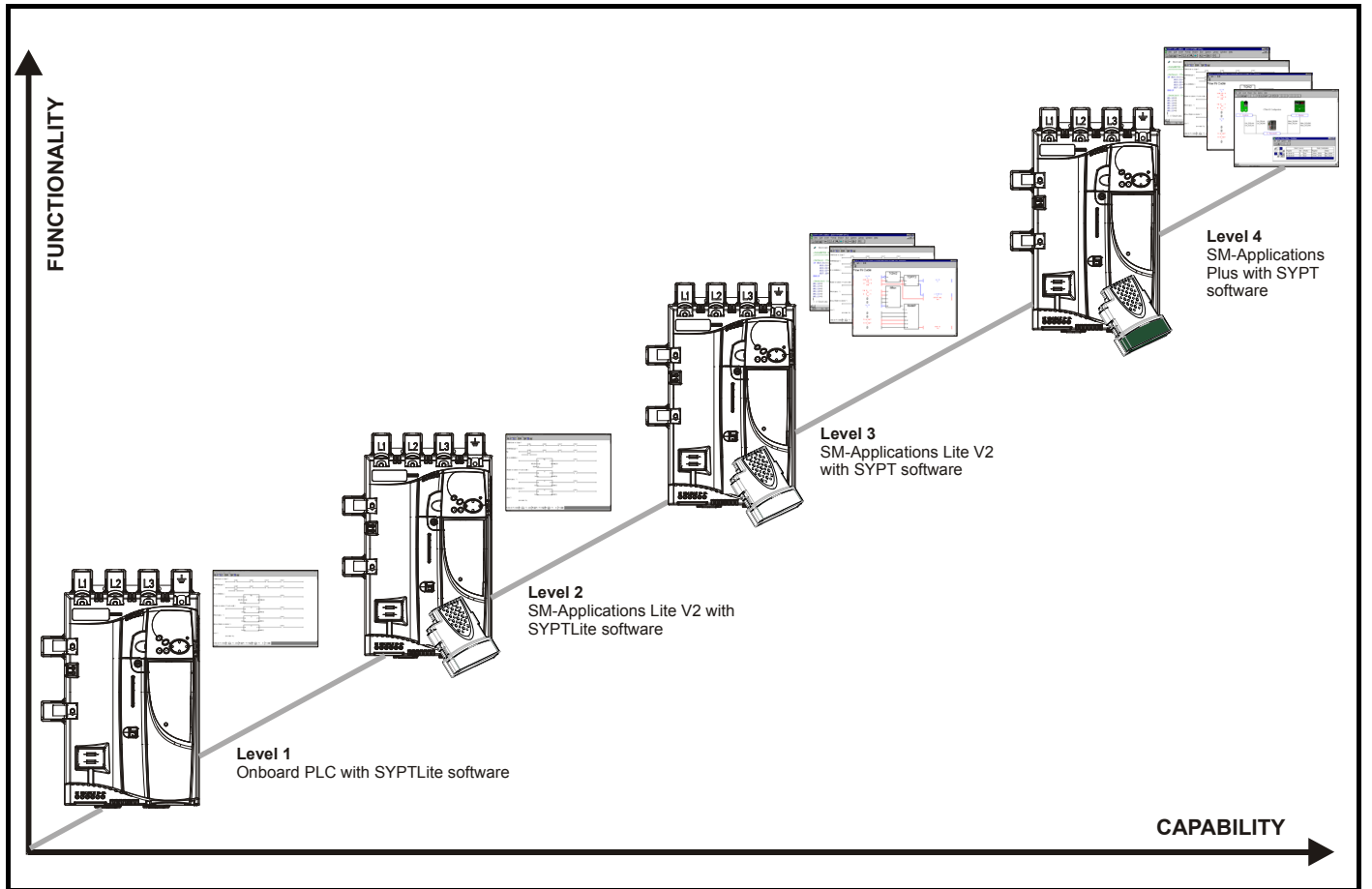
The user program is scheduled for a short period approximately once every 64 ms. The time for which the program is scheduled will vary between 0.2 ms and 2ms depending on the loading of the drive's processor.

When scheduled, several scans of the user program may be performed. Some scans may execute in microseconds. However, when the main drive functions are scheduled there will be a pause in the execution of the program causing some scans to take many milliseconds. SYPT Lite displays the average execution time calculated over the last 10 scans of the user program.

The Onboard PLC and SYPT Lite form the first level of functionality in a range of programmable options for Mentor MP.

- SYPT Lite can be used with either the Onboard PLC or with SM-Applications Lite V2 to create ladder logic programs.
- SYPT can be used with either the SM-Applications Lite V2 or SM-Applications Plus to create fully flexible programs using ladder logic, function blocks or DPL script.

Figure 10-2 Programming options for Mentor MP



## 10.4 Getting started

SYPT Lite is available to download at: [www.controltechniques.com](http://www.controltechniques.com).

### SYPTLite system requirements

- Windows 2000/XP/Vista. **Windows 95/98/98SE/Me/NT4 are not supported**
- Pentium III 500 MHz or better recommended
- 128 MB RAM
- Minimum of 800 x 600 screen resolution. 1024 x 768 is recommended
- Adobe Acrobat 5.10 or later (for viewing User Guides)
- Microsoft Internet Explorer V5.0 or later
- RS232 to RS485, RJ45 communications lead to connect the PC to the drive
- Administrator rights are required to install the software

See the SYPTLite help file for more information regarding using SYPTLite, creating ladder diagrams and the available function blocks.

## 10.5 Onboard PLC parameters

The following parameters are associated with the Onboard PLC program.

11.47		Drive Onboard PLC program enable					
RW	Uni					US	
↕		0 to 2			⇒	2	

This parameter is used to start and stop the drive Onboard PLC program.

Value	Description
0	Halt the drive Onboard PLC program.
1	Run the drive Onboard PLC program (if installed). Any out-of-range parameter writes attempted will be clipped to the maximum / minimum values valid for that parameter before being written.
2	Run the drive Onboard PLC program (if installed). Any out-of-range parameter writes attempted will cause a 'UP ovr' trip.

11.48		Drive Onboard PLC program status					
RO	Bi				NC	PT	
↕		-128 to +127			⇒		

The drive Onboard PLC program status parameter indicates to the user the actual state of the drive Onboard PLC program.

Value	Description
-n	Onboard PLC program caused a drive trip due to an error condition while running rung n. Note that the rung number is shown on the display as a negative number.
0	Onboard PLC program is not installed.
1	Onboard PLC program is installed but stopped.
2	Onboard PLC program is installed and running.

When an Onboard PLC program is installed and running, the lower display of the drive flashes 'PLC' once every 10 s.

11.49		Drive Onboard PLC programming events											
RO	Uni						NC	PT				PS	
↕		0 to 65,535					⇒						

The drive Onboard PLC programming events parameter holds the number of times an Onboard PLC program download has taken place and is 0 on dispatch from the factory. The drive is rated for one hundred ladder program downloads. This parameter is not altered when defaults are loaded.

11.50		Drive Onboard PLC program average scan time											
RO	Uni						NC	PT					
↕		0 to 65,535 ms					⇒						

This parameter is updated once per second or once per Onboard PLC program scan whichever is the longest. If more than one program scan occurs within the one second update period the parameter shows the average scan time. If the program scan time is longer than one second the parameter shows the time for the last program scan.

11.51		Drive Onboard PLC program first run											
RO	Bit						NC	PT					
↕		OFF (0) or On (1)					⇒						

The Drive Onboard PLC program first run parameter is set for the duration of program scan from the stopped state. This enables the user to perform any required initialisation every time the program is run. This parameter is set every time the program is stopped.

## 10.6 Onboard PLC trips

The following trips are associated with the Onboard PLC program.

Trip	Diagnosis
<b>UP ACC</b>	<b>Onboard PLC program: Cannot access Onboard PLC program file on drive</b>
<b>98</b>	Disable drive - write access is not allowed when the drive is enabled. Another source is already accessing Onboard PLC program - retry once the other action is complete.
<b>UP div0</b>	<b>Onboard PLC program attempted divide by zero</b>
<b>90</b>	Check program
<b>UP OFL</b>	<b>Onboard PLC program variables and function block calls using more than the allowed RAM space (stack overflow)</b>
<b>95</b>	Check program
<b>UP ovr</b>	<b>Onboard PLC program attempted out of range parameter write</b>
<b>94</b>	Check program
<b>UP PAr</b>	<b>Onboard PLC program attempted access to a non-existent parameter</b>
<b>91</b>	Check program
<b>UP ro</b>	<b>Onboard PLC program attempted write to a read-only parameter</b>
<b>92</b>	Check program
<b>UP So</b>	<b>Onboard PLC program attempted read of a write-only parameter</b>
<b>93</b>	Check program
<b>UP udF</b>	<b>Onboard PLC program undefined trip</b>
<b>97</b>	Check program
<b>UP uSEr</b>	<b>Onboard PLC program requested a trip</b>
<b>96</b>	Check program

## 10.7 Onboard PLC and the SMARTCARD

The Onboard PLC program in a drive may be transferred from the drive to a SMARTCARD and vice versa.

- To transfer an Onboard PLC program from the drive to a SMARTCARD, set Pr **xx.00** to 5yyy and reset the drive
- To transfer an Onboard PLC program from the SMARTCARD to a drive, set Pr **xx.00** to 6yyy and reset the drive.


(Where yyy is the data block location, see Table 9-1 *SMARTCARD data blocks* on page 88 for restrictions on block numbers).

If an attempt is made to transfer an Onboard PLC program from a drive to the SMARTCARD when the drive contains no program, the block is still created on the SMARTCARD but it will contain no data. If this data block is then transferred to a drive, the destination drive will then have no Onboard PLC program.

The smallest SMARTCARD compatible with Mentor MP has a capacity of 4064 bytes and each block can be up to 4064 bytes in size. The maximum size of a user program is 4032 bytes so it is guaranteed that any Onboard PLC program downloaded to a Mentor MP will fit on to an empty SMARTCARD. A SMARTCARD can contain a number of Onboard PLC programs until the capacity of the card is used.

# 11 Advanced parameters

This is a quick reference to all parameters in the drive showing units, ranges, limits etc, with block diagrams to illustrate their function. Full parameter descriptions can be found in the *Mentor MP Advanced User Guide*.



**WARNING** These advanced parameters are listed for reference purposes only. The lists in this chapter do not include sufficient information for adjusting these parameters. Incorrect adjustment can affect the safety of the system, and damage the drive and or external equipment. Before attempting to adjust any of these parameters, refer to the *Mentor MP Advanced User Guide*.

**Table 11-1 Menu descriptions**

Menu	Function
0	Commonly used basic set-up parameters for quick / easy programming
1	Speed reference selection, limits and filters
2	Ramps
3	Speed feedback and speed control
4	Torque and current control
5	Motor and field control
6	Sequencer and clock
7	Analog I/O
8	Digital I/O
9	Programmable logic and motorized pot
10	Drive status and trip information
11	General drive set-up
12	Threshold detectors, variable selectors and brake control function
13	Position control
14	User PID controller
15	Slot 1 Solutions Module menu
16	Slot 2 Solutions Module menu
17	Slot 3 Solutions Module menu
18	User application menu 1 (saved in drive EEPROM)
19	User application menu 2 (saved in drive EEPROM)
20	User application menu 3 (not saved in drive EEPROM)
21	Second motor parameters
22	Additional Menu 0 set up
23	Header selections

**Default abbreviations:**

- Eur> European default value
- USA> USA default value

**NOTE**

Parameter numbers shown in brackets {...} are the equivalent sub block/ Menu 0 parameters.

In some cases, the function or range of a parameter is affected by the setting of another parameter; the information in the lists relates to the default condition of such parameters.

**Coding**

The coding defines the attributes of the parameter as follows.

**Table 11-2 Key to parameter table coding**

Coding	Attribute
{X.XX}	Copied Menu 0 or advanced parameter
Bit	1 bit parameter: 'On' or 'OFF' on the display
Bi	Bipolar parameter
Uni	Unipolar parameter
Txt	Text: the parameter uses text strings instead of numbers.
SP	Spare: not used
FI	Filtered: some parameters which can have rapidly changing values are filtered when displayed on the drive keypad for easy viewing.
DE	Destination pointer parameter: This parameter can be used to set up the location (i.e. menu/parameter number) where the destination data is to be routed.
VM	Variable maximum: the maximum of this parameter can vary.
DP	Decimal place: indicates the number of decimal places used by this parameter.
ND	No default: when defaults are loaded (except when the drive is manufactured or on EEPROM failure) this parameter is not modified.
RA	Rating dependant: this parameter is likely to have different values and ranges with drives of different voltage and current ratings. Parameters with this attribute will not be transferred to the destination drive by a SMARTCARD when the rating of the destination drive is different from the source drive if the drive voltage ratings are different or the file is a parameter file. However, the value will be transferred if only the current rating is different and the file is a differences from default type file.
NC	Not copied: not transferred to or from SMARTCARD during copying.
NV	Not visible: not visible on the keypad.
PT	Protected: cannot be used as a destination.
US	User save: saved in drive EEPROM when the user initiates a parameter save.
RW	Read/write: can be written by the user.
RO	Read only: can only be read by the user
BU	Bit default one/unsigned: Bit parameters with this flag set to one have a default of one (all other bit parameters have a default of zero. Non-bit parameters are unipolar if this flag is one.
PS	Power-down save: parameter automatically saved in drive EEPROM when the under volts (UV) trip occurs. Power-down save parameters are also saved in the drive when the user initiates a parameter save.

**Table 11-3 Feature look-up table**

Feature	Related parameters (Pr)													
Acceleration rates	2.10	2.11 to 2.19	2.32	2.33	2.34	2.02								
Analog speed reference 1	1.36	7.10	7.01	7.07	7.08	7.09	7.25	7.26	7.30					
Analog speed reference 2	1.37	7.14	1.41	7.02	7.11	7.12	7.13	7.28	7.31					
Analog I/O	Menu 7													
Analog input 1	7.01	7.07	7.08	7.09	7.10	7.25	7.26	7.30						
Analog input 2	7.02	7.11	7.12	7.13	7.14	7.28	7.31							
Analog input 3	7.03	7.15	7.16	7.17	7.18	7.29	7.32							
Analog output 1	7.19	7.20	7.21	7.33										
Analog output 2	7.22	7.23	7.24											
Application menu	Menu 18		Menu 19		Menu 20									
Armature IR compensation	5.88													
Armature mode	5.43													
At speed indicator bit	3.06	3.07	3.09	10.06	10.05	10.07								
Auto reset	10.34	10.35	10.36	10.01										
Autotune	4.13	4.14	4.34	5.12	5.15	5.23	5.24	5.29	5.30	5.59	5.61	5.70	5.72	5.74
Bridge request output	5.44													
Binary sum	9.29	9.30	9.31	9.32	9.33	9.34								
Bipolar speed	1.10													
Brake control	12.40 to 12.49													
Catch a spinning motor	6.09													
Coast to stop	6.01													
Comms	11.23 to 11.26													
Copying	11.42	11.36 to 11.40												
Cost - per kWh electricity	6.16	6.17	6.24	6.25	6.26	6.40								
Current controller	4.13	4.14	4.34	5.15										
Current feedback	4.01	4.02	4.16	4.19	4.20	4.27	4.28	4.29	4.30	4.31	4.32	10.08	10.17	
Current limits	4.05	4.06	4.07	4.18	5.07	10.09								
Deceleration rates	2.20	2.21 to 2.29		2.04	2.35 to 2.37		2.02	2.08	6.01					
Defaults	11.46													
Digital I/O	Menu 8													
Digital I/O read word	8.20													
Digital I/O T24	8.01	8.11	8.21	8.31										
Digital I/O T25	8.02	8.12	8.22	8.32										
Digital I/O T26	8.03	8.13	8.23	8.33										
Digital input T27	8.04	8.14	8.24											
Digital input T28	8.05	8.15	8.25	8.39										
Digital input T29	8.06	8.16	8.26	8.39										
Digital lock	13.10	13.01 to 13.09		13.11	13.12	13.16	3.22	3.23	13.19 to 13.23					
Direction	10.13	6.30	6.31	3.01	3.02	10.14	8.03	8.04						
Display timeout	11.41													
Drive active	10.02													
Drive OK	10.01	8.27	8.07	8.17	10.36									
Electronic nameplate	3.49													
Enable	6.15	8.09	8.10											
Encoder reference	3.43	3.44	3.45	3.46										
Encoder set up	3.33	3.34 to 3.42		3.47	3.48									
External flux feedback	5.89													
External flux feedback select	5.48													
External trip	10.32	8.10	8.07											
Fan speed	6.45													
Field IR compensation	5.87													
Filter change	6.19	6.18												
Hard speed reference	3.22	3.23												
I/O sequencer	6.04	6.30	6.31	6.32	6.33	6.34	6.42	6.43	6.40					
Inertia compensation	2.38	5.12	4.22	3.18										
Jog reference	1.05	2.19	2.29											
Keypad reference	1.17	1.14	1.43	1.51	6.12	6.13								
Limit switches	6.35	6.36												
Line power supply loss	6.03	5.05												
Local position reference	13.20 to 13.23													
Logic function 1	9.01	9.04	9.05	9.06	9.07	9.08	9.09	9.10						
Logic function 2	9.02	9.14	9.15	9.16	9.17	9.18	9.19	9.20						
Marker pulse	3.32	3.31												

Feature	Related parameters (Pr)												
Maximum speed	1.06												
Menu 0 set up	22.01 to 22.21		Menu 22										
Minimum speed	1.07	10.04											
Modules - number of	11.35												
Motor map	5.07	5.08	5.09	5.70	5.73								
Motor map 2	Menu 21		11.45										
Motorized potentiometer	9.21	9.22	9.23	9.24	9.25	9.26	9.27	9.28					
Offset speed reference	1.04	1.38	1.09										
Onboard PLC	11.47 to 11.51												
Open collector digital outputs	8.30												
Orientation	13.10	13.13 to 13.15											
Output	5.01	5.02	5.03										
Overspeed threshold	3.08												
PID controller	Menu 14												
Position feedback - drive	3.28	3.29	3.30	3.50									
Positive logic	8.29												
Power up parameter	11.22	11.21											
Precision reference	1.18	1.19	1.20	1.44									
Preset speeds	1.15	1.21 to 1.28		1.16	1.14	1.42	1.45 to 1.48		1.50				
Programmable logic	Menu 9												
Regenerating	10.10												
Relative jog	13.17 to 13.19												
Relay output	8.07	8.17	8.27	8.40	8.50	8.60							
Reset	10.33	8.02	8.22	10.34	10.35	10.36	10.01						
S ramp	2.06	2.07											
Security code	11.30	11.44											
Serial comms	11.23 to 11.26												
Skip speeds	1.29	1.30	1.31	1.32	1.33	1.34	1.35						
Slave bridge request status	5.45 to 5.47												
SMARTCARD	11.36 to 11.40		11.42										
Software version	11.29	11.34											
Speed controller	3.10 to 3.17		3.20	3.21									
Speed feedback	3.02	3.03											
Speed feedback - drive	3.26	3.27	3.28	3.29	3.31	3.42	3.52	3.55	3.56	3.57	3.58		
Speed reference selection	1.14	1.15	1.49	1.50	1.01								
Status word	10.40												
Supply	5.05												
Thermal protection - drive	7.04	7.34	10.18										
Thermal protection - motor	4.15	5.07	4.19	4.16	4.25	7.15							
Thermistor input	7.15	7.03											
Threshold detector 1	12.01	12.03 to 12.07											
Threshold detector 2	12.02	12.23 to 12.27											
Time - filter change	6.19	6.18											
Time - powered up log	6.20	6.21	6.28										
Time - run log	6.22	6.23	6.28										
Torque	4.03	4.26	5.32										
Torque mode	4.08	4.11	4.09	4.10									
Trip detection	10.20 to 10.29												
Trip log	10.20 to 10.29		10.41 to 10.51		6.28								
Under voltage	5.05												
Variable selector 1	12.08 to 12.15												
Variable selector 2	12.28 to 12.35												
Velocity feed forward	1.39	1.40											
Voltage rating	11.33	5.09	5.05										
Warning	10.19	10.17	10.18	10.40									
Zero speed indicator bit	3.05	10.03											

## Parameter ranges and variable maximums:

The two values provided define the minimum and maximum values for the given parameter. In some cases the parameter range is variable and dependant on either:

- other parameters
- the drive rating
- or a combination of these

The values given in Table 11-4 are the variable maximums used in the drive.

**Table 11-4 Definition of parameter ranges & variable maximums**

Maximum	Definition
MAX_SPEED_REF [10000.0 rpm]	<b>Maximum speed reference</b> If Pr 1.08 = 0: MAX_SPEED_REF = Pr 1.06 (SE02, 0.23) If Pr 1.08 = 1: MAX_SPEED_REF is Pr 1.06 (SE02, 0.23) or – Pr 1.07 (SE01, 0.22) whichever is the largest (If the second motor map is selected Pr 21.01 is used instead of Pr 1.06 (SE02, 0.23) and Pr 21.02 instead of Pr 1.07 (SE01, 0.22))
SPEED_LIMIT_MAX [10000.0 rpm]	<b>Maximum applied to speed reference limits</b> A maximum limit may be applied to the speed reference to prevent the nominal encoder frequency from exceeding 500kHz. The maximum is defined by SPEED_LIMIT_MAX (in rpm) = 500kHz x 60 / ELPR = 3.0 x 10 <sup>7</sup> / ELPR subject to an absolute maximum of 10,000 rpm. ELPR is equivalent encoder lines per revolution and is the number of lines that would be produced by a quadrature encoder. Quadrature encoder ELPR = number of lines per revolution F and D encoder ELPR = number of lines per revolution / 2 This maximum is defined by the device selected with the speed feedback selector (Pr 3.26 (Fb01, 0.71)) and the ELPR set for the position feedback device.
SPEED_MAX [10000.0 rpm]	<b>Maximum speed</b> This maximum is used for some speed related parameters in menu 3. To allow headroom for overshoot etc. the maximum speed is twice the maximum speed reference. SPEED_MAX = 2 x MAX_SPEED_REF
MAX_RAMP_RATE MAX_RAMP_RATE_M2 [3200.000]	<b>Maximum ramp rate</b> If (Pr 1.06 (SE02, 0.23) [Pr 21.01] >= 1000 and Pr 2.39 = 0) or Pr 2.39 >= 1000 then MAX_RAMP_RATE = 3200.000 Else if Pr 2.39 = 0 MAX_RAMP_RATE = 3200 * Pr 1.06 (SE02, 0.23) [Pr 21.01] / 1000.0 Else MAX_RAMP_RATE = 3200 * Pr 2.39 / 1000.0 <b>End if</b>
RATED_CURRENT_MAX [9999.99A]	<b>Maximum motor rated current</b>
DRIVE_CURRENT_MAX [9999.99A]	<b>Maximum drive current</b> The maximum drive current is the current at the over current trip level and is given by: DRIVE_CURRENT_MAX = RATED_CURRENT_MAX x 2
MOTOR1_CURRENT_LIMIT_MAX [1000.0 %]	<b>Maximum current limit settings for motor map 1</b> This maximum current limit setting is the maximum applied to the current limit parameters in motor map 1. See introduction to Menu 4 for the definition.
MOTOR2_CURRENT_LIMIT_MAX [1000.0 %]	<b>Maximum current limit settings for motor map 2</b> This maximum current limit setting is the maximum applied to the current limit parameters in motor map 2. See introduction to Menu 4 for the definition.
TORQUE_PROD_CURRENT_MAX [1000.0 %]	<b>Maximum torque producing current</b> This is used as a maximum for torque and torque producing current parameters. It is MOTOR1_CURRENT_LIMIT_MAX or MOTOR2_CURRENT_LIMIT_MAX depending on which motor map is currently active.
USER_CURRENT_MAX [1000.0 %]	<b>Current parameter limit selected by the user</b> The user can select a maximum for Pr 4.08 (torque reference) and Pr 4.20 (percentage load) to give suitable scaling for analog I/O with Pr 4.24. This maximum is subject to a limit of CURRENT_LIMIT_MAX. USER_CURRENT_MAX = Pr 4.24

Maximum	Definition
ARMATURE_VOLTAGE_MAX [1025]	<p><b>Maximum armature voltage</b>  <math>V_{ac} \times 1.35 (\sqrt{2} \times 3 / \pi)</math>            480 +10 % drive: 720            575 +10 % drive: 860            690 +10 % drive: 1025</p> <p><b>NOTE</b>            For 4 quadrant drives maximum armature voltage = <math>V_{ac} \times 1.15</math></p>
QUADRANT_MAX	<p><b>Quadrant maximum</b>            0 for a 2 quadrant drive.            1 for a 4 quadrant drive.</p>
POWER_MAX [9999.99kW]	<p><b>Maximum power in kW</b>            The maximum power has been chosen to allow for the maximum power that can be output by the drive with maximum DC output voltage and maximum controlled current.            Therefore:  <math>POWER\_MAX = ARMATURE\_VOLTAGE\_MAX \times DRIVE\_CURRENT\_MAX</math></p>

The values given in square brackets indicate the absolute maximum value allowed for the variable maximum.

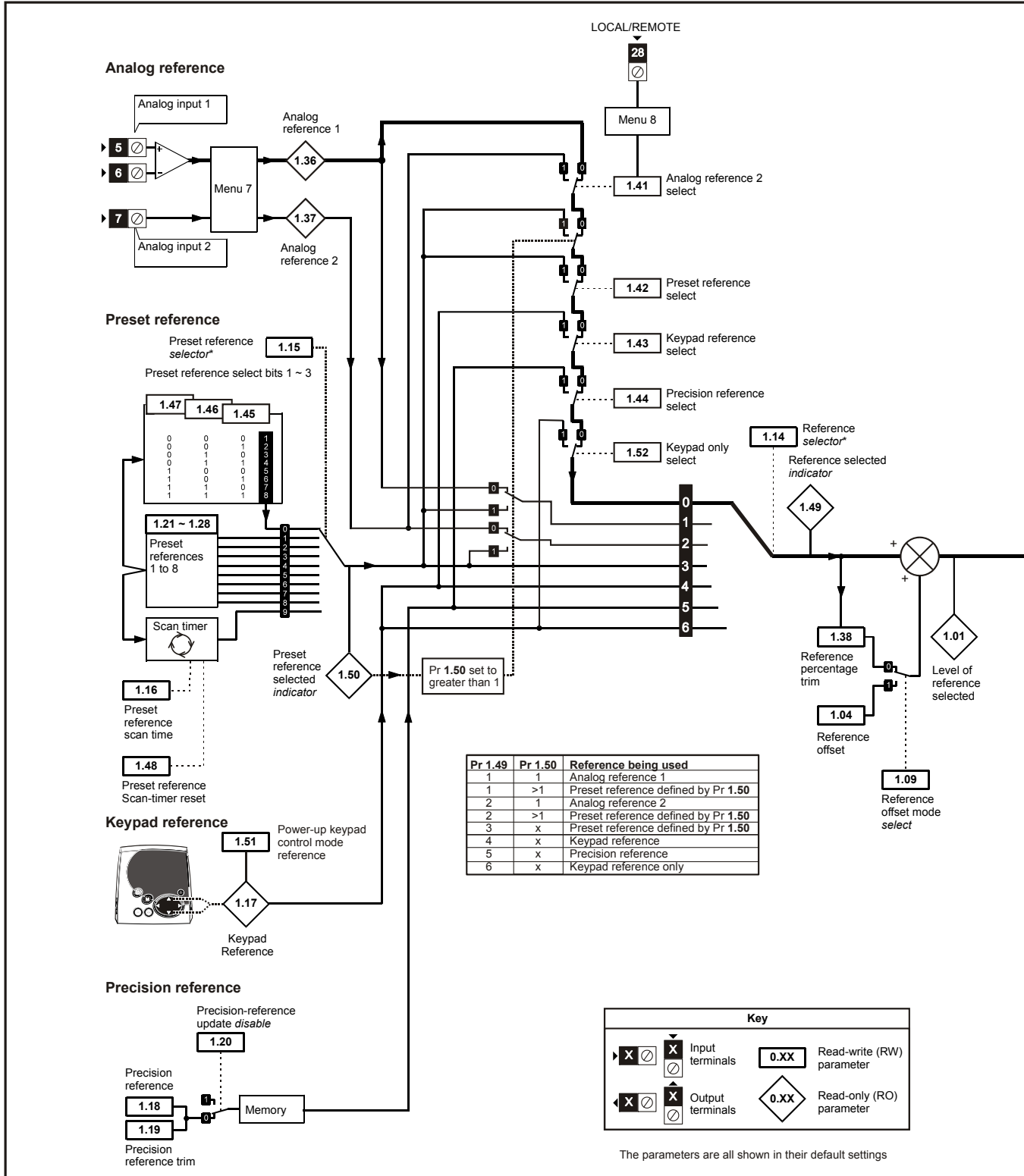


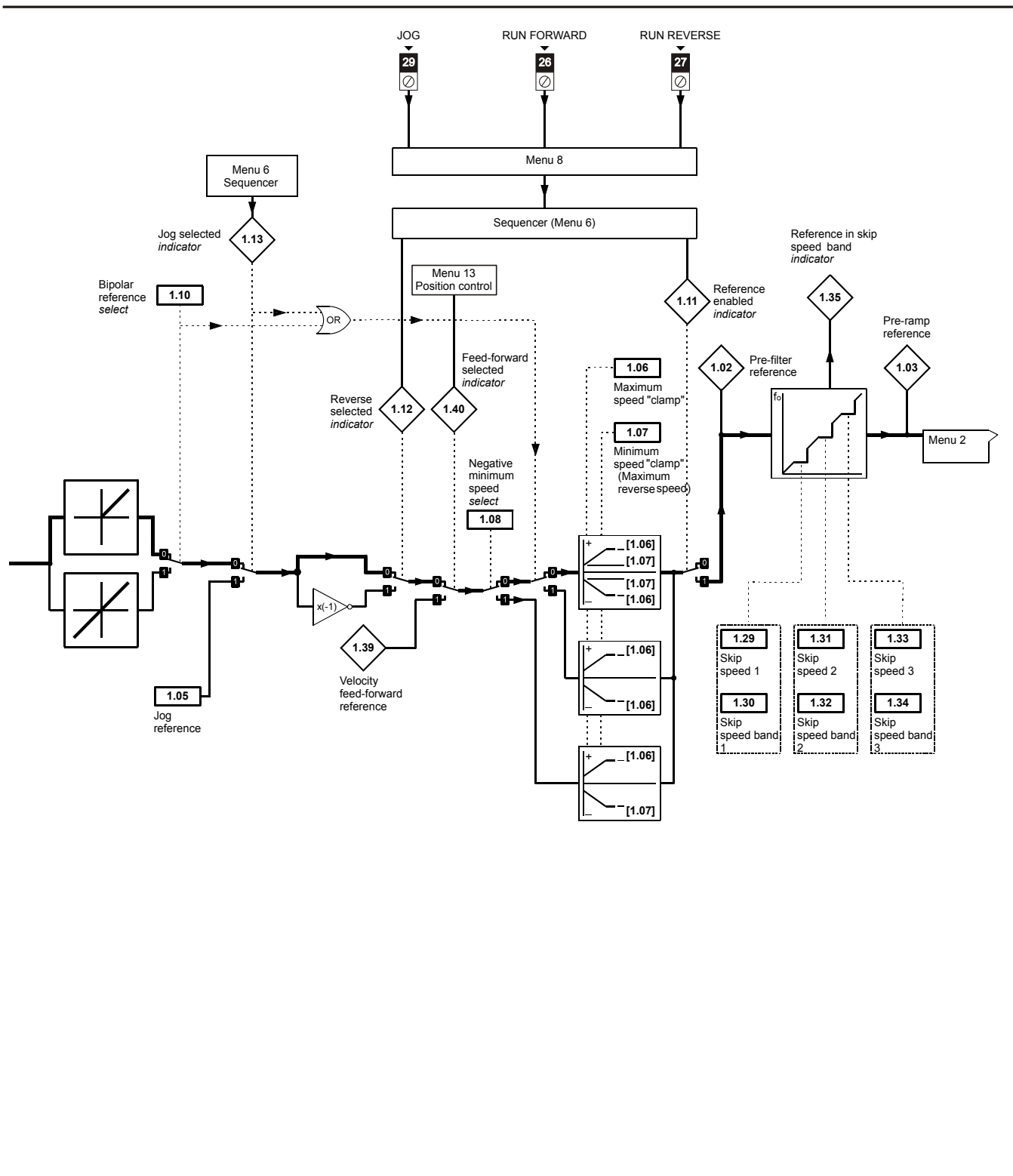


# 11.1 Menu 1: Speed reference

Menu 1 controls the main reference selection.

Figure 11-1 Menu 1 logic diagram





\*Refer to Pr 1.14 (SE05, 0.26) for further information.

Parameter		Range(⇅)	Default(⇄)	Type				
1.01	Speed reference selected {di01, 0.36}	±MAX_SPEED_REF rpm		RO	Bi	NC	PT	
1.02	Pre-skip filter reference			RO	Bi	NC	PT	
1.03	Pre-ramp reference {di02, 0.37}	±10,000.0 rpm	0.0	RO	Bi	NC	PT	
1.04	Reference offset			RW	Bi			US
1.05	Jog reference	0 to 1,000.0 rpm		RW	Uni			US
1.06	Maximum reference clamp {SE02, 0.23}	SPEED_LIMIT_MAX rpm	1000.0	RW	Uni			US
1.07	Minimum reference clamp {SE01, 0.22}	±SPEED_LIMIT_MAX rpm*	0.0	RW	Bi		PT	US
1.08	Negative minimum reference clamp enable	OFF (0) or On (1)	OFF (0)	RW	Bit			US
1.09	Reference offset select			RW	Bit			US
1.10	Bipolar reference enable			RW	Bit			US
1.11	Reference enabled indicator {di11, 0.46}			RO	Bit	NC	PT	
1.12	Reverse selected indicator {di12, 0.47}			RO	Bit	NC	PT	
1.13	Jog selected indicator {di13, 0.48}			RO	Bit	NC	PT	
1.14	Reference selector {SE05, 0.26}	0 to 6	0 (A1.A2)	RW	Txt			US
1.15	Preset selector	0 to 9	0	RW	Uni			US
1.16	Preset reference selector timer	0 to 400.0 s	10.0	RW	Uni			US
1.17	Keypad control reference	±MAX_SPEED_REF rpm	0.0	RO	Bi	NC	PT	PS
1.18	Precision reference coarse	±MAX_SPEED_REF rpm		RW	Bi			US
1.19	Precision reference fine	0.0 to 0.099 rpm	0.000	RW	Uni			US
1.20	Precision reference update disable	OFF (0) or On (1)	OFF (0)	RW	Bit	NC		
1.21	Preset reference 1	±MAX_SPEED_REF rpm	0.0	RW	Bi			US
1.22	Preset reference 2			RW	Bi			US
1.23	Preset reference 3			RW	Bi			US
1.24	Preset reference 4			RW	Bi			US
1.25	Preset reference 5			RW	Bi			US
1.26	Preset reference 6			RW	Bi			US
1.27	Preset reference 7			RW	Bi			US
1.28	Preset reference 8			RW	Bi			US
1.29	Skip reference 1	0 to 10,000 rpm	0	RW	Uni			US
1.30	Skip reference band 1	0 to 250 rpm	5	RW	Uni			US
1.31	Skip reference 2	0 to 10,000 rpm	0	RW	Uni			US
1.32	Skip reference band 2	0 to 250 rpm	5	RW	Uni			US
1.33	Skip reference 3	0 to 10,000 rpm	0	RW	Uni			US
1.34	Skip reference band 3	0 to 250 rpm	5	RW	Uni			US
1.35	Reference in rejection zone	OFF (0) or On (1)		RO	Bit	NC	PT	
1.36	Analog reference 1	±MAX_SPEED_REF rpm	0	RO	Bi	NC		
1.37	Analog reference 2			RO	Bi	NC		
1.38	Percentage trim	±100.00 %	0.00	RW	Bi	NC		
1.39	Velocity feed-forward reference	±10,000.0 rpm		RO	Bi	NC	PT	
1.40	Feed forward selected	OFF (0) or On (1)	OFF (0)	RO	Bit	NC	PT	
1.41	Analog reference 2 select			RW	Bit	NC		
1.42	Preset reference select			RW	Bit	NC		
1.43	Keypad reference select			RW	Bit	NC		
1.44	Precision reference select			RW	Bit	NC		
1.45	Preset reference select bit 1			RW	Bit	NC		
1.46	Preset reference select bit 2			RW	Bit	NC		
1.47	Preset reference select bit 3			RW	Bit	NC		
1.48	Preset reference scan timer reset	RW	Bit	NC				
1.49	Reference selected indicator	1 to 6		RO	Uni	NC		
1.50	Preset reference selected indicator	1 to 8		RO	Uni	NC	PT	
1.51	Power-up keypad reference control mode	0 to 2	0	RW	Txt			US
1.52	Keypad reference only select	OFF (0) or On (1)	OFF (0)	RW	Bit	NC		

\*The range shown for Pr 1.07 shows the range used for scaling purposes (i.e. for routing to an analog output etc). Further range restrictions are applied depending on the settings of Pr 1.08 and Pr 1.10.

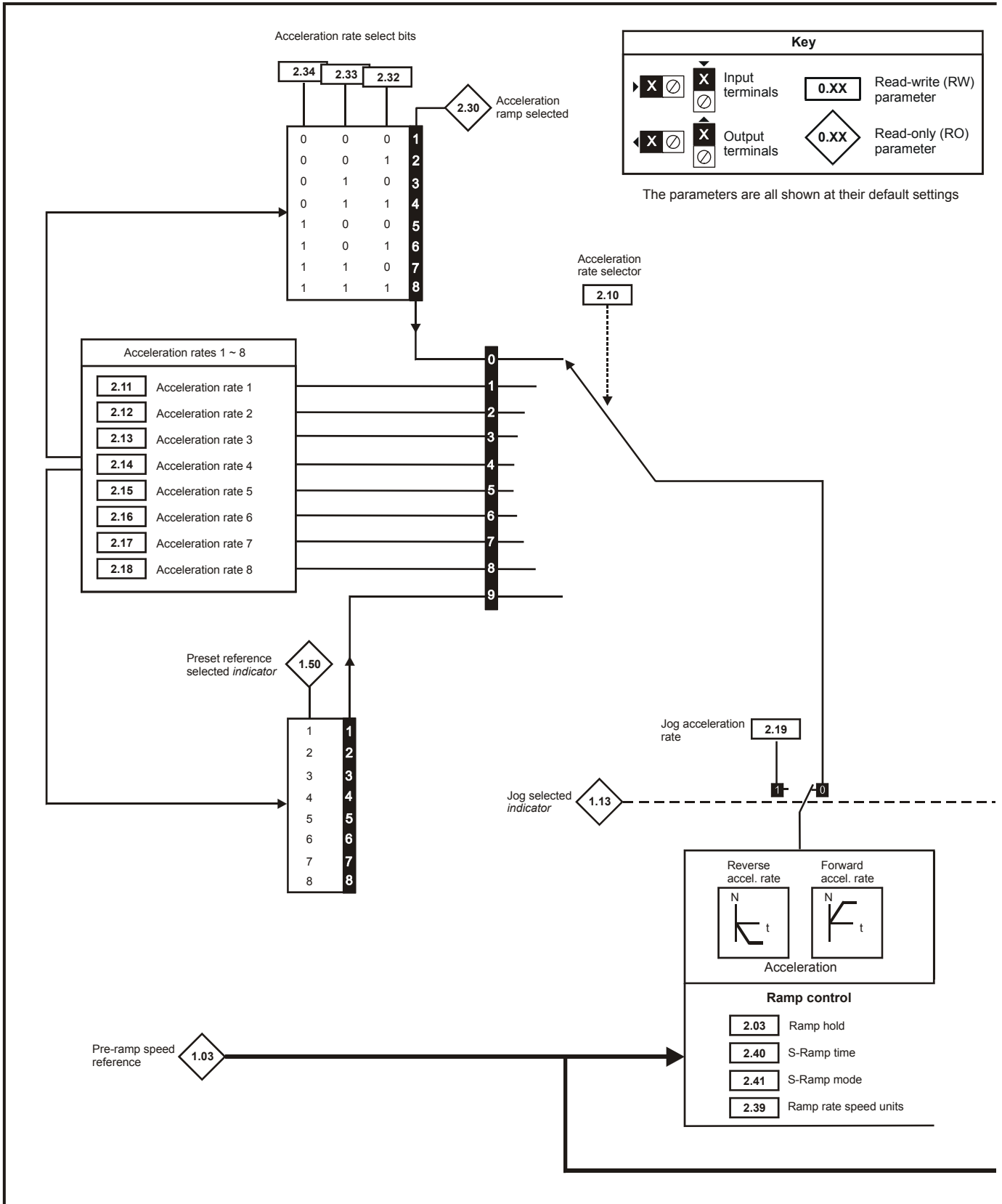
RW	Read / Write	RO	Read only	Uni	Unipolar	Bi	Bi-polar	Bit	Bit parameter	Txt	Text string		
FI	Filtered	DE	Destination	NC	Not copied	RA	Rating dependent	PT	Protected	US	User save	PS	Power down save

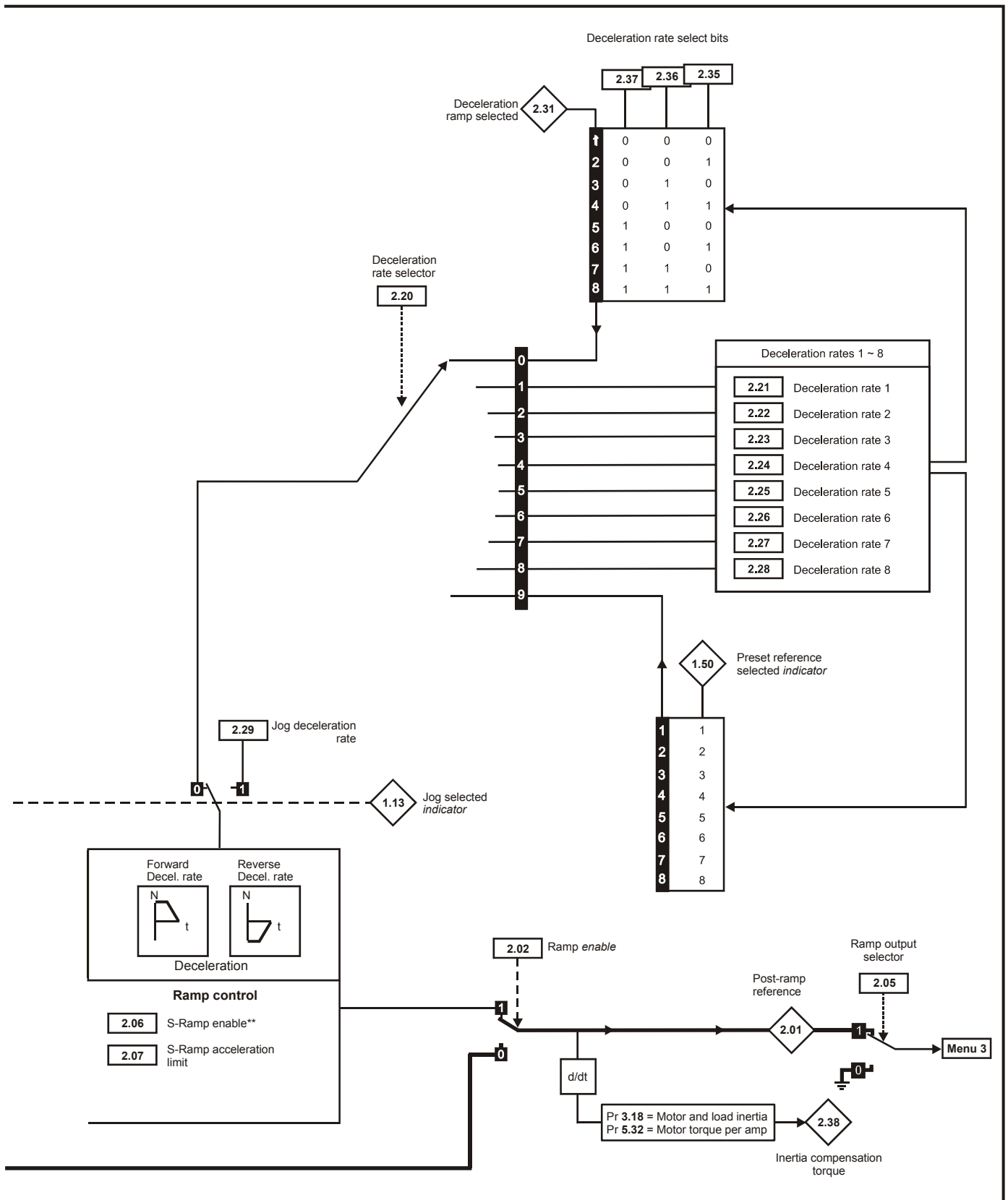


## 11.2 Menu 2: Ramps

The pre-ramp speed reference passes through the ramp block controlled by menu 2 before being used by the drive to produce input to the speed controller. The ramp block includes: linear ramps, and an S ramp function for ramped acceleration and deceleration.

Figure 11-2 Menu 2 logic diagram





\*\* For more information refer to the *Mentor MP Advanced User Guide*.

Parameter		Range(↕)	Default(⇔)	Type					
2.01	Post ramp reference {di03, 0.38}	±SPEED_MAX rpm		RO	Bi		NC	PT	
2.02	Ramp enable		On (1)	RW	Bit				US
2.03	Ramp hold		0	RW	Bit				US
2.05	Ramp output selector	OFF (0) or On (1)	On (1)	RW	Bit				US
2.06	S ramp enable		0 Eur: 0, USA: 1	RW	Bit				US
2.07	S ramp acceleration limit	0 to 100.000 s <sup>2</sup> /1000 rpm	3.600	RW	Uni				US
2.10	Acceleration rate selector	0 to 9	0	RW	Uni				US
2.11	Acceleration rate 1 {SE03, 0.24}			RW	Uni				US
2.12	Acceleration rate 2			RW	Uni				US
2.13	Acceleration rate 3			RW	Uni				US
2.14	Acceleration rate 4			RW	Uni				US
2.15	Acceleration rate 5	0 to MAX_RAMP_RATE s / (Pr 1.06 OR Pr 2.39)	5.000	RW	Uni				US
2.16	Acceleration rate 6			RW	Uni				US
2.17	Acceleration rate 7			RW	Uni				US
2.18	Acceleration rate 8			RW	Uni				US
2.19	Jog acceleration rate			RW	Uni				US
2.20	Deceleration rate selector	0 to 9	0	RW	Uni				US
2.21	Deceleration rate 1 {SE04, 0.25}			RW	Uni				US
2.22	Deceleration rate 2			RW	Uni				US
2.23	Deceleration rate 3			RW	Uni				US
2.24	Deceleration rate 4			RW	Uni				US
2.25	Deceleration rate 5	0 to MAX_RAMP_RATE s / (Pr 1.06 OR Pr 2.39)	5.000	RW	Uni				US
2.26	Deceleration rate 6			RW	Uni				US
2.27	Deceleration rate 7			RW	Uni				US
2.28	Deceleration rate 8			RW	Uni				US
2.29	Jog deceleration rate		10.000	RW	Uni				US
2.30	Acceleration ramp selected			RO	Uni		NC	PT	
2.31	Deceleration ramp selected	1 to 8		RO	Uni		NC	PT	
2.32	Acceleration select bit 0			RW	Bit		NC		
2.33	Acceleration select bit 1			RW	Bit		NC		
2.34	Acceleration select bit 2			RW	Bit		NC		
2.35	Deceleration select bit 0	OFF (0) or On (1)		RW	Bit		NC		
2.36	Deceleration select bit 1			RW	Bit		NC		
2.37	Deceleration select bit 2			RW	Bit		NC		
2.38	Inertia compensation torque	± 1,000.0 %		RO	Bi		NC	PT	
2.39	Ramp rate speed units	0 to 10000 rpm	0	RW	Uni				US
2.40	Time of S ramp	0 to 100.000 s	1.250	RW	Uni				US
2.41	S ramp mode	OFF (0) or On (1)	On (1)	RW	Bit				US

RW	Read / Write	RO	Read only	Uni	Unipolar	Bi	Bi-polar	Bit	Bit parameter	Txt	Text string		
FI	Filtered	DE	Destination	NC	Not copied	RA	Rating dependent	PT	Protected	US	User save	PS	Power down save



## 11.3 Menu 3: Speed feedback and speed control

### Speed accuracy and resolution

#### Digital reference resolution

When a preset speed is used the reference resolution is 0.1 rpm. Improved resolution can be obtained by using the precision reference (0.001 rpm).

#### Analog reference resolution

The analog input has a maximum resolution of 14 bits plus sign. The resolution of the reference from analog inputs 2 or 3 is 10 bits plus sign.

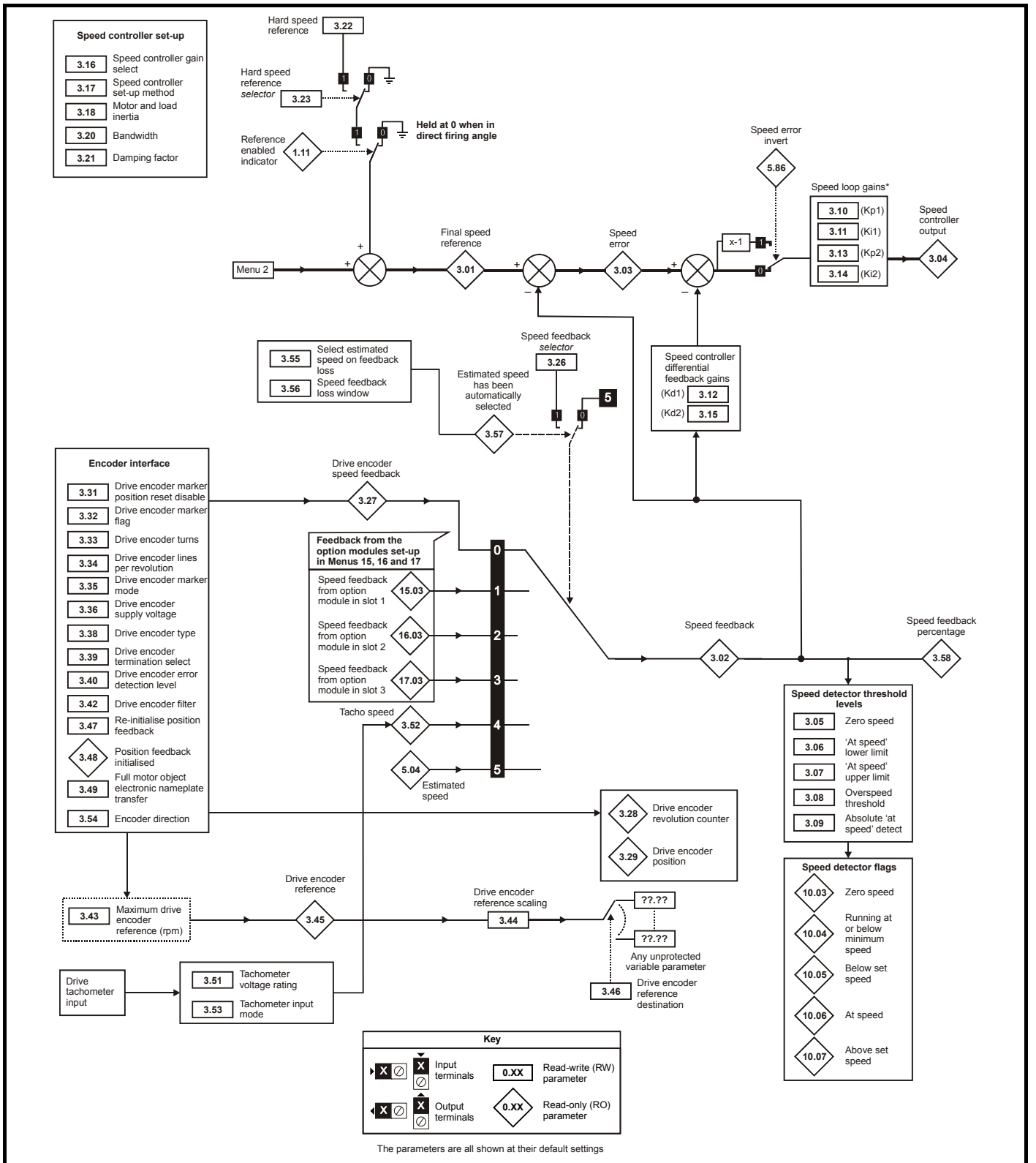
#### Analog feedback resolution

The resolution for both Armature voltage and tachogenerator feedback is 10 bit plus sign.

#### Accuracy

With encoder feedback the absolute speed accuracy depends on the accuracy of the crystal used with the drive microprocessor. The accuracy of the crystal is 100 ppm, and so the absolute speed accuracy is 100 ppm (0.01 %) of the reference, when a preset speed is used. If an analog input is used the absolute accuracy is further limited by the absolute accuracy and non-linearity of the analog input. If analog feedback is used the accuracy is even further limited.

Figure 11-3 Menu 3 logic diagram



\* If Pr 5.28 (Field weakening compensation disable) is set to 'OFF (0)' a multiplication factor is applied to the speed loop gains when the flux is below 100 %.

Parameter		Range(⇅)	Default(⇒)	Type					
3.01	Final speed reference {di04, 0.39}	±SPEED_MAX rpm		RO	Bi	FI	NC	PT	
3.02	Speed feedback {di05, 0.40}			RO	Bi	FI	NC	PT	
3.03	Speed error			RO	Bi	FI	NC	PT	
3.04	Speed controller output {di06, 0.41}	±Torque_prod_current_max %		RO	Bi	FI	NC	PT	
3.05	Zero speed threshold	0 to 200 rpm	30	RW	Uni				US
3.06	At speed lower limit	0 to 10,000 rpm	5	RW	Uni				US
3.07	At speed upper limit			RW	Uni				US
3.08	Overspeed threshold			RW	Uni				US
3.09	Absolute 'at speed' detect	OFF (0) or On (1)	OFF (0)	RW	Bit				US
3.10	Speed controller proportional gain (Kp1) {SP01, 0.61}	0.0 to 6.5535 (1 / rad/s))	0.0300	RW	Uni				US
3.11	Speed controller integral gain (Ki1) {SP02, 0.62}	0 to 655.35 (s / rad/s))	0.10	RW	Uni				US
3.12	Speed controller differential feedback gain (Kd1) {SP03, 0.63}	0 to 0.65535 (1/s / rad/s))	0.00000	RW	Uni				US
3.13	Speed controller proportional gain (Kp2)	0.0 to 6.5535 (1 / rad/s))	0.0300	RW	Uni				US
3.14	Speed controller integral gain (Ki2)	0 to 655.35 (s / rad/s))	0.10	RW	Uni				US
3.15	Speed controller differential feedback gain (Kd2)	0 to 0.65535 (1/s / rad/s))	0.00000	RW	Uni				US
3.16	Speed controller gain select	OFF (0) or On (1)	OFF (0)	RW	Bit				US
3.17	Speed controller set-up method	0 to 2	0	RW	Uni				US
3.18	Motor and load inertia	0.0 to 90.00000 kg m <sup>2</sup>	0.00000	RW	Uni				US
3.20	Bandwidth	0 to 50 Hz	1	RW	Uni				US
3.21	Damping factor	0.0 to 10.0	1.0	RW	Uni				US
3.22	Hard speed reference	-MAX_SPEED_REF to MAX_SPEED_REF rpm	0.0	RW	Bi				US
3.23	Hard speed reference selector	OFF (0) or On (1)	OFF (0)	RW	Bit				US
3.26	Speed feedback selector {Fb01, 0.71}	0 to 5	5	RW	Txt				US
3.27	Drive encoder speed feedback {Fb09, 0.79}	±10,000.0 rpm		RO	Bi	FI	NC	PT	
3.28	Drive encoder revolution counter	±32,768 revolutions		RO	Bi	FI	NC	PT	
3.29	Drive encoder position	0 to 65,535 1/2 <sup>16</sup> ths of a revolution		RO	Uni	FI	NC	PT	
3.31	Drive encoder marker position reset disable	OFF (0) or On (1)	OFF (0)	RW	Bit				US
3.32	Drive encoder marker flag			RW	Bit		NC		
3.33	Drive encoder turn bits	0 to 16	16	RW	Uni				US
3.34	Drive encoder lines per revolution {Fb05, 0.75}	1 to 50,000	1024	RW	Uni				US
3.35	Drive encoder marker mode	0 to 1		RW	Uni				US
3.36	Drive encoder supply voltage {Fb06, 0.76}	0 to 3	0	RW	Txt				US
3.38	Drive encoder type {Fb07, 0.77}			RW	Txt				US
3.39	Drive encoder termination select {Fb08, 0.78}	0 to 2	1	RW	Uni				US
3.40	Drive encoder error detection level		0	RW	Uni				US
3.42	Drive encoder filter	0 to 5 (0 to 16 ms)	2	RW	Txt				US
3.43	Maximum drive encoder reference	0 to 10,000 rpm	1000	RW	Uni				US
3.44	Drive encoder reference scaling	0 to 4.000	1.000	RW	Uni				US
3.45	Drive encoder reference	±100.0 %		RO	Bi	FI	NC	PT	
3.46	Drive encoder reference destination	0 to 22.99	0.00	RW	Uni		DE	PT	US
3.47	Re-initialise position feedback	OFF (0) or On (1)		RW	Bit		NC		
3.48	Position feedback initialised			RW	Bit		NC	PT	
3.49	Full motor object electronic nameplate transfer			RW	Bit				US
3.50	Position feedback lock		OFF (0)	RW	Bit		NC		
3.51	Tachometer voltage rating {Fb02, 0.72}	0 to 300.00 v/1000 rpm	Eur:60.00, USA 50.00	RW					US
3.52	Tachometer speed feedback {Fb04, 0.74}	±SPEED_MAX rpm		RO	Bi	FI	NC	PT	
3.53	Tachometer input mode {Fb03, 0.73}	0 to 2	0 (DC)	RW	Txt				US
3.54	Encoder direction	OFF (0) or On (1)	OFF (0)	RW	Bit				US
3.55	Select estimated speed on feedback loss			RW	Bit				US
3.56	Speed feedback loss window	0 to 100.0 %	20.0 %	RW					US
3.57	Estimated speed has been automatically selected	OFF (0) or On (1)		RO	Bit				
3.58	Speed feedback percentage	±100.0 %		RO			NC	PT	

RW	Read / Write	RO	Read only	Uni	Unipolar	Bi	Bi-polar	Bit	Bit parameter	Txt	Text string		
FI	Filtered	DE	Destination	NC	Not copied	RA	Rating dependent	PT	Protected	US	User save	PS	Power down save

## 11.4 Menu 4: Torque and current control

MOTOR1\_CURRENT\_LIMIT\_MAX is used as the maximum for some parameters such as the user current limits. The current maximum current limit is defined as follows (with a maximum of 1000 %):

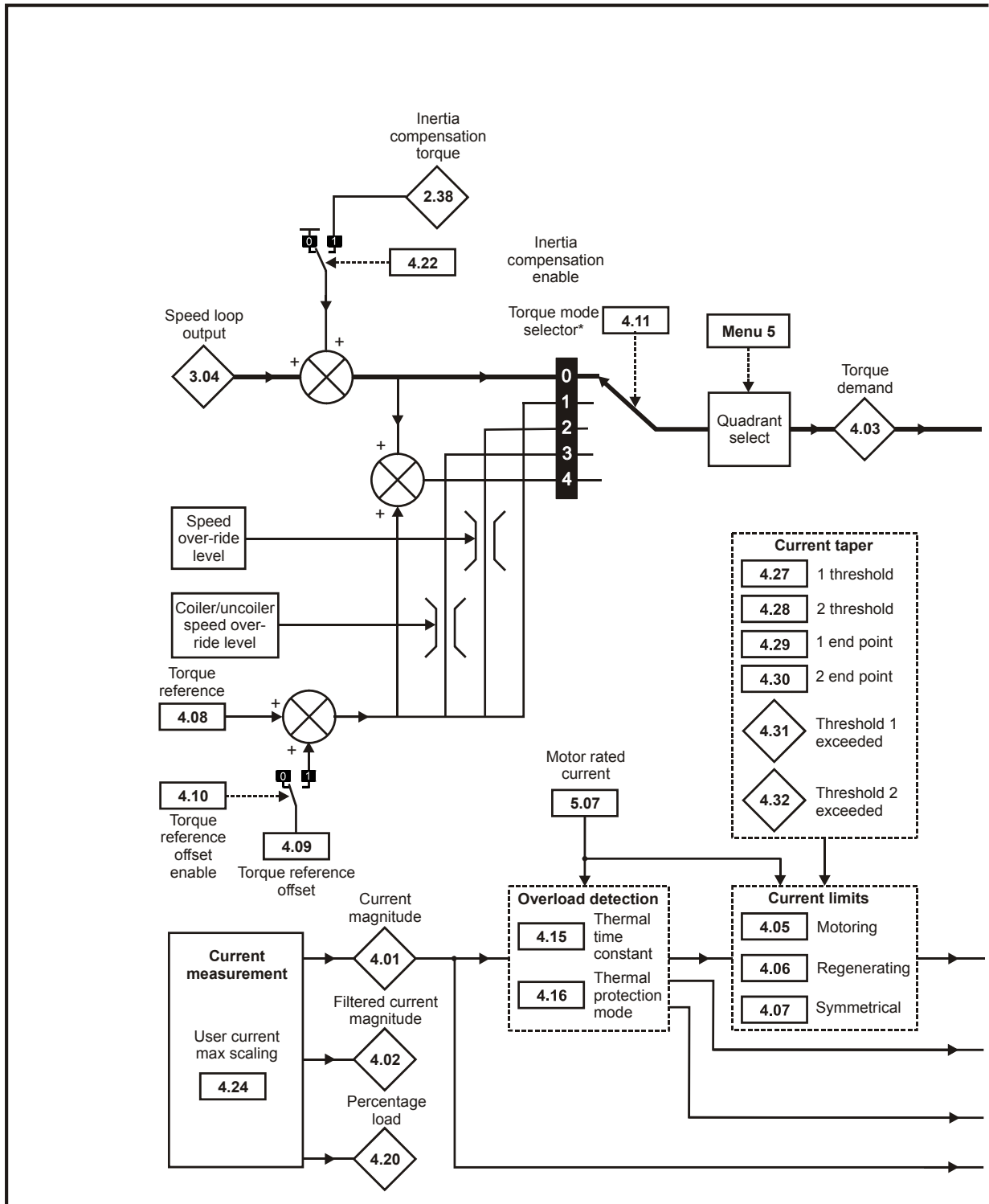
$$\text{CURRENT\_LIMIT\_MAX} = \left[ \frac{\text{Maximum current}}{\text{Motor rated current}} \right] \times 100 \%$$

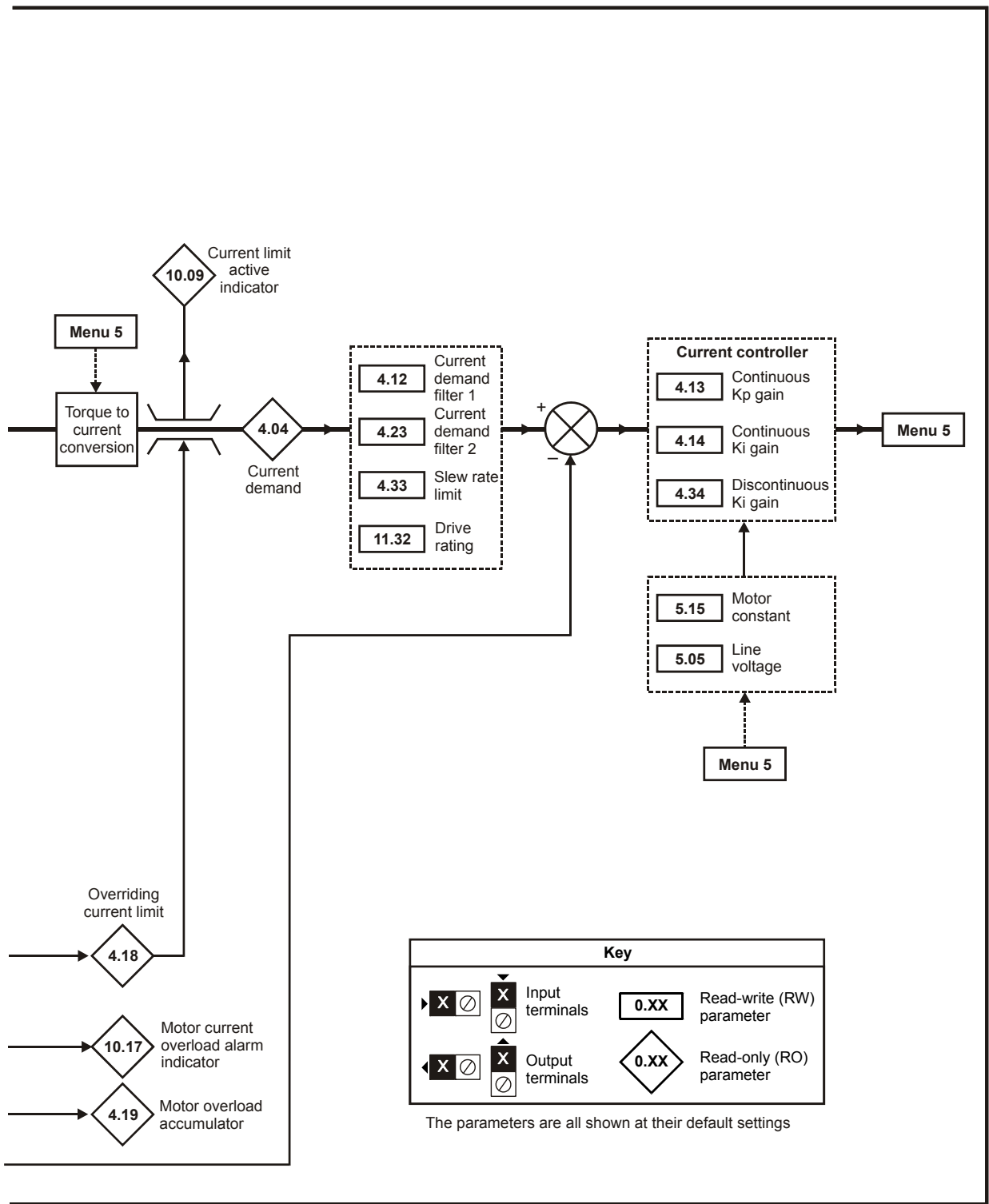
Where:

Motor rated current is given by Pr 5.07 (SE07, 0.28)

(MOTOR2\_CURRENT\_LIMIT\_MAX is calculated from the motor map 2 parameters). The maximum current is 1.5 x drive rating.

Figure 11-4 Menu 4 logic diagram





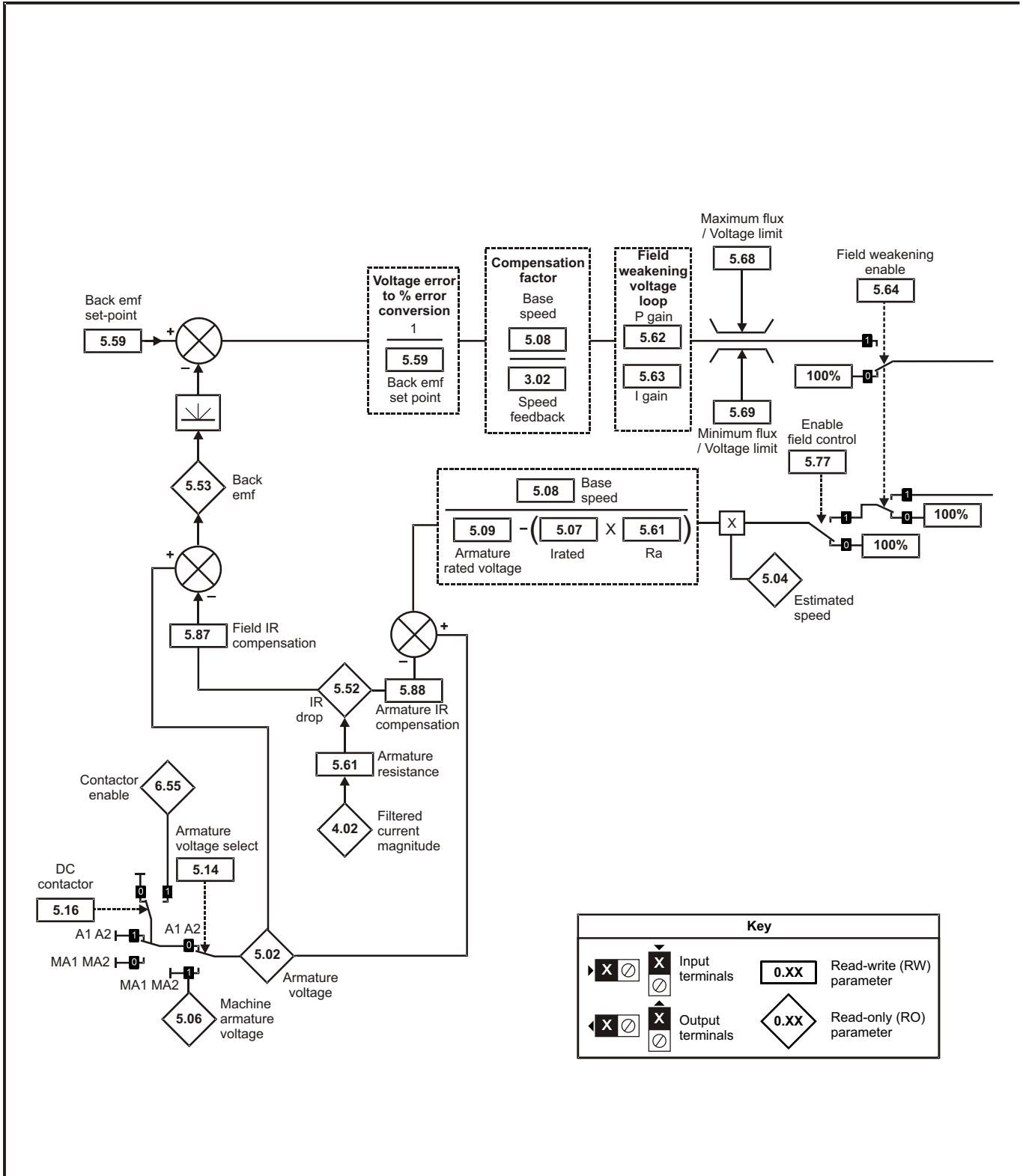
Parameter		Range(⇅)	Default(⇒)	Type					
4.01	Current magnitude {di08, 0.43}	±DRIVE_CURRENT_MAX A		RO	Uni	FI	NC	PT	
4.02	Filtered current magnitude			RO	Uni	FI	NC	PT	
4.03	Torque demand {di07, 0.42}	±TORQUE_PROD_CURRENT_MAX %		RO	Bi	FI	NC	PT	
4.04	Current demand			RO	Bi	FI	NC	PT	
4.05	Motoring current limit	0 to MOTOR1_CURRENT_LIMIT_MAX %	150.0	RW	Uni		RA		US
4.06	Regen current limit			RW	Uni		RA		US
4.07	Symmetrical current limit			RW	Uni		RA		US
4.08	Torque reference			RW	Bi				US
4.09	Torque offset	±USER_CURRENT_MAX %	0.0	RW	Bi				US
4.10	Torque offset select			OFF (0) or On (1)	OFF (0)	RW	Bit		
4.11	Torque mode selector	0 to 4	0	RW	Uni				US
4.12	Current demand filter 1	0.0 to 25.0 ms	6.0	RW	Uni				US
4.13	Continuous current controller Kp gain	0 to 4,000	100	RW	Uni		RA		US
4.14	Continuous current controller Ki gain			50	RW	Uni		RA	
4.15	Thermal time constant	0 to 3000.0	89.0	RW	Uni				US
4.16	Thermal protection mode	0 to 1	0	RW	Bit				US
4.18	Overriding current limit	0 to TORQUE_PROD_CURRENT_MAX %		RO	Uni		NC	PT	
4.19	Overload accumulator	0 to 100.0 %		RO	Uni		NC	PT	
4.20	Percentage load	±USER_CURRENT_MAX %		RO	Bi	FI	NC	PT	
4.22	Inertia compensation enable	OFF (0) or On (1)	OFF (0)	RW	Bit				US
4.23	Current demand filter 2	0.0 to 25.0 ms	6.0	RW	Uni				US
4.24	User current maximum scaling	0.0 to TORQUE_PROD_CURRENT_MAX%	150.0	RW	Uni		RA		US
4.27	Current taper 1 threshold	0 to 10,000.0 rpm	10,000.0 rpm	RW	Uni				US
4.28	Current taper 2 threshold			RW	Uni				US
4.29	Current taper 1 end point			RW	Uni				US
4.30	Current taper 2 end point	0 to 1000.0 %	1000.0 %	RW	Uni				US
4.31	Taper threshold 1 exceeded	OFF (0) or On (1)		RO	Bit				
4.32	Taper threshold 2 exceeded			RO	Bit				
4.33	Slew rate limit	0.0 to 60,000 %s <sup>-1</sup>	7000	RW	Uni				US
4.34	Discontinuous current controller Ki gain	0 to 4,000	200	RW	Uni		RA		US
4.35	Extra safe bridge change	OFF (0) or On (1)	OFF (0)	RW	Bit				US
4.36	Reduced hysteresis for bridge change over			RW	Bit				US

RW	Read / Write	RO	Read only	Uni	Unipolar	Bi	Bi-polar	Bit	Bit parameter	Txt	Text string		
FI	Filtered	DE	Destination	NC	Not copied	RA	Rating dependent	PT	Protected	US	User save	PS	Power down save

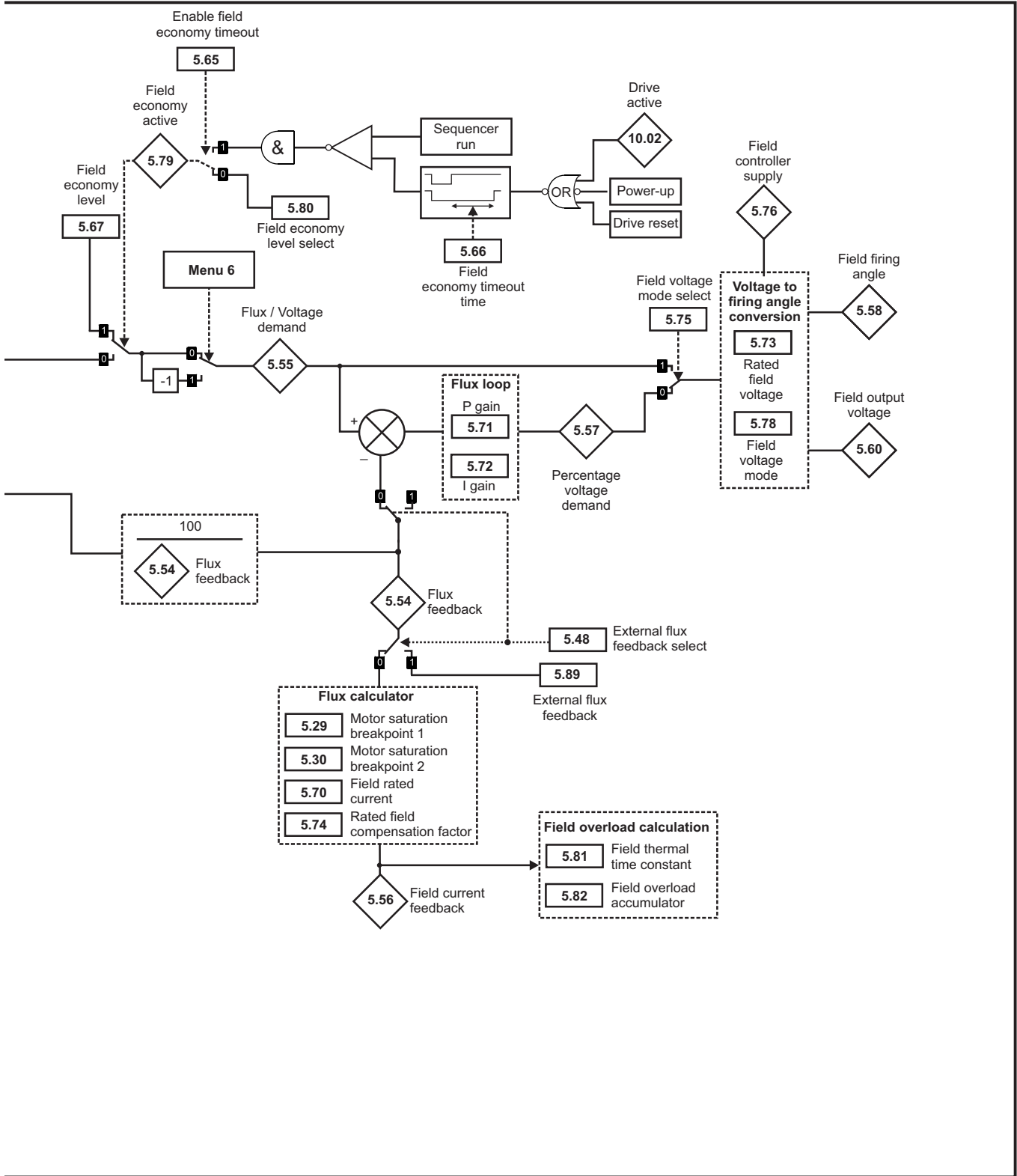


## 11.5 Menu 5: Motor and field control

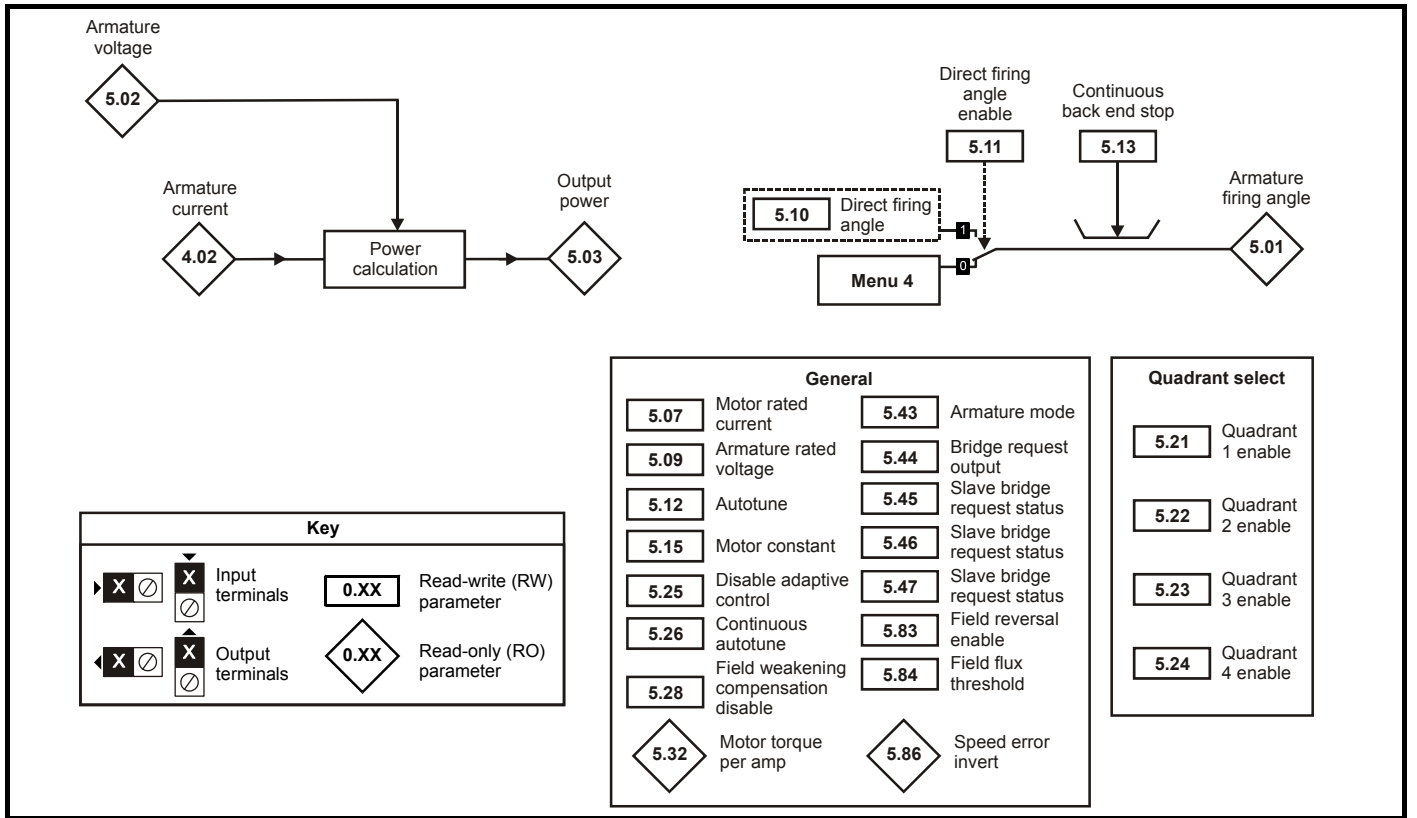
Figure 11-5 Menu 5 field control logic diagram







**Figure 11-6 Menu 5 armature control logic diagram**



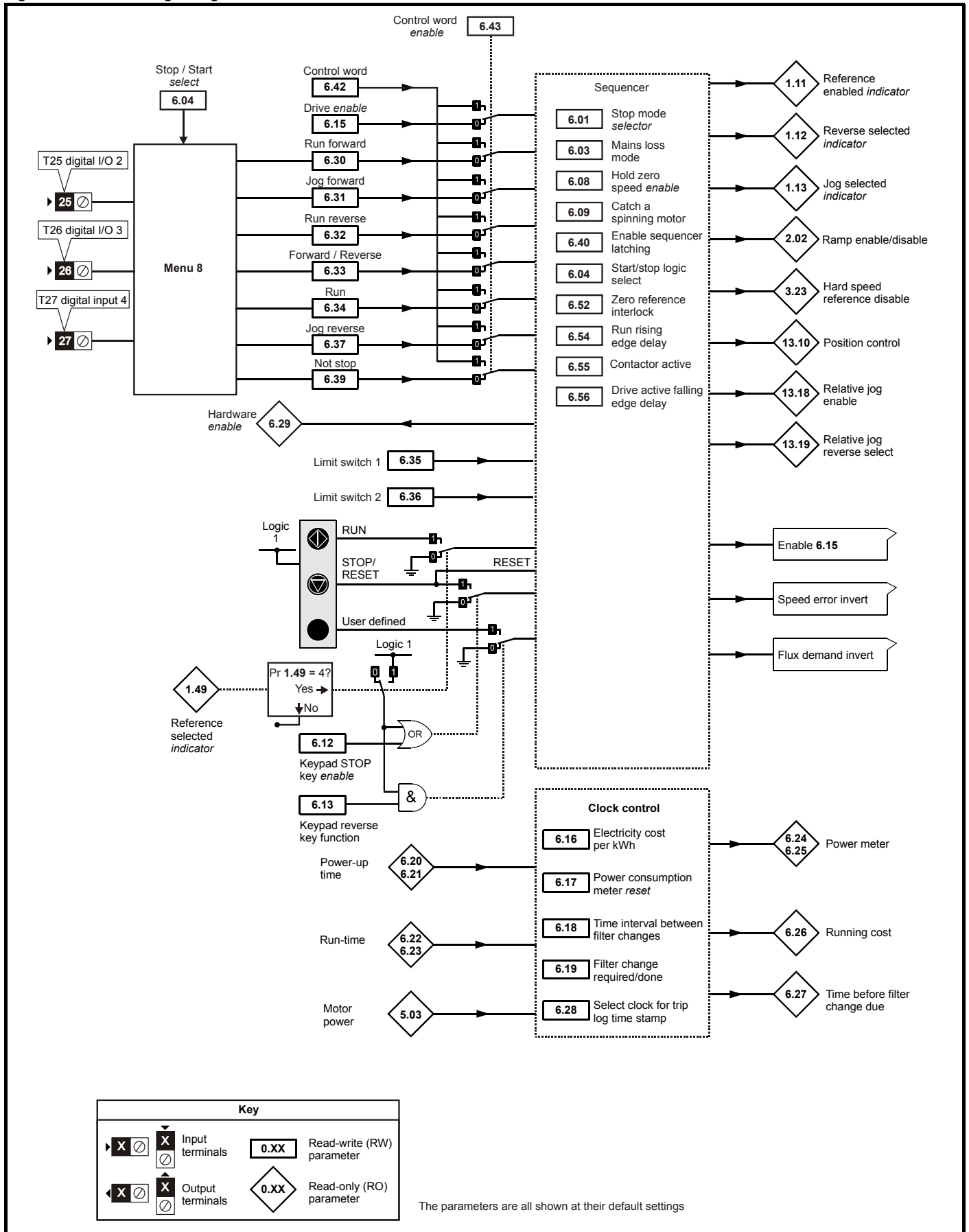
Parameter		Range(⇅)	Default(⇔)	Type						
5.01	Armature firing angle	0 to 175.0 °		RO	Uni	FI	NC	PT		
5.02	Armature voltage {di10, 0.45}	±ARMATURE_VOLTAGE_MAX V		RO	Bi	FI	NC	PT		
5.03	Output power	±POWER_MAX kW		RO	Bi	FI	NC	PT		
5.04	Estimated speed	±SPEED_MAX rpm		RO	Bi	FI	NC	PT		
5.05	Line voltage	0 to 1000V rms AC		RO	Uni	FI	NC	PT		
5.06	Machine armature voltage	±ARMATURE_VOLTAGE_MAX V		RO	Bi	FI	NC	PT		
5.07	Motor rated current {SE07, 0.28}	0 to RATED_CURRENT_MAX A	RATED_CURRENT_MAX	RW	Uni		RA		US	
5.08	Base speed {SE08, 0.29}	0.0 to 10,000.0 rpm	1,000.0	RW	Uni				US	
5.09	Armature rated voltage {SE06, 0.27}	0 to ARMATURE_VOLTAGE_MAX Vdc	For 480V drive: 440 Eur 500 USA For 575V drive: 630 Eur 630 USA For 690V drive: 760 Eur 760 USA	RW	Uni		RA		US	
5.10	Direct firing angle	0 to 165.0 °	165.0	RW	Uni					
5.11	Direct firing angle enable	OFF (0) or On (1)	OFF (0)	RW	Bit				US	
5.12	Autotune {SE13, 0.34}	0 to 3	0	RW	Uni		NC			
5.13	Continuous Back End Stop	0 to 165.0 °	165.0	RW	Uni				US	
5.14	Armature voltage select	OFF (0) or On (1)	OFF (0)	RW	Bit				US	
5.15	Motor constant	0 to 100.0 %	50.0 %	RW	Uni				US	
5.16	DC contactor	OFF (0) or On (1)	OFF (0)	RW	Bit				US	
5.18	Resistive load mode	OFF (0) or On (1)	OFF (0)	RW	Bit				US	
5.21	Quadrant 1 Enable	0 to 1	1	RW	Uni				US	
5.22	Quadrant 2 Enable			RW	Uni				US	
5.23	Quadrant 3 Enable			RW	Uni				US	
5.24	Quadrant 4 Enable			RW	Uni		RA		US	
5.25	Disable adaptive control	OFF (0) or On (1)	OFF (0)	RW	Bit				US	
5.26	Continuous auto tune			RW	Bit				US	
5.28	Field weakening compensation disable			Eur: 1, USA: 1	RW	Bit				US
5.29	Motor saturation breakpoint 1	0 to 100 % of rated flux	50	RW	Uni				US	
5.30	Motor saturation breakpoint 2		75	RW	Uni				US	
5.32	Motor torque per amp	0.000 to 50.000 NmA <sup>-1</sup>		RO	Uni					
5.43	Armature mode	0 to 8	0	RW	Txt				US	
5.44	Bridge request output	0 to 1		RW	Bit					
5.45				RW	Bit					
5.46	Slave bridge request status			RW	Bit					
5.47				RW	Bit					
5.48	External flux feedback select	OFF (0) or On (1)	OFF (0)	RW	Bit				US	
5.52	IR drop	±ARMATURE_VOLTAGE_MAX Vdc		RO	Bi	FI	NC	PT		
5.53	Back emf			RO	Bi	FI	NC	PT		
5.54	Flux feedback			±150 %	RO	Bi	FI	NC	PT	
5.55	Flux / Voltage demand			±120 %	RW	Bi	FI	NC	PT	
5.56	Field current feedback {di09, 0.44}			±50.00 A	RO	Bi	FI	NC	PT	
5.57	Percentage voltage demand			±150.0 %	RO	Bi	FI	NC	PT	
5.58	Field firing angle			0 to 180.0 °	RO	Uni	FI	NC	PT	
5.59	Back emf set point	0 to ARMATURE_VOLTAGE_MAX Vdc	For 480V Drive: 440 Eur 500 USA For 575V Drive: 630 Eur 630 USA For 690V Drive: 760 Eur 760 USA	RW	Uni				US	
5.60	Field output voltage	0 to 500 Vdc		RO	Uni	FI	NC	PT		
5.61	Armature Resistance	0 to 6.0000 Ω	0.0000	RW	Uni				US	
5.62	field weakening loop P gain	0 to 300.00	0.40	RW	Uni				US	
5.63	field weakening loop I gain		5.00	RW	Uni				US	
5.64	Field weakening enable	0 to 1	0	RW	Bit				US	
5.65	Enable field economy timeout		Eur: 0, USA: 1	RW	Bit				US	
5.66	Field economy timeout time	0 to 255 s	30 s	RW	Uni				US	
5.67	Field economy level	0 to 120.0 %	25.0 %	RW	Uni				US	
5.68	Maximum flux / Voltage limit	0 to MAX_FIELD_FLUX %	100.0 %	RW	Uni				US	
5.69	Minimum flux / Voltage limit	0 to 120.0 %	50.0 %	RW	Uni				US	
5.70	Rated field current {SE10, 0.31}	0 to FIELD_CURRENT_SET_MAX	Size 1 - Eur: 2A , USA: 8A Size 2A & B - Eur: 3A, USA: 20A Size 2C & D - Eur: 5A, USA: 20A	RW	Uni		RA	PT	US	
5.71	Flux loop P gain	0 to 30.00	3.00	RW	Uni			PT	US	
5.72	Flux loop I gain	0 to 300.00	60.00	RW	Uni				US	
5.73	Rated field voltage {SE11, 0.32}	0 to 500.0 Vdc	Eur: 360, USA: 300	RW	Uni				US	
5.74	Rated field compensation factor	0 to 100 %	100 %	RW	Uni			PT	US	
5.75	Field voltage mode select	0 to 1	Eur: 0, USA: 1	RW	Bit				US	

Parameter		Range(↕)	Default(↔)	Type					
5.76	Field controller supply	0 to 550 rms Vac		RO	Uni	FI	NC	PT	
5.77	Enable field control {SE12, 0.33}	0 to 1	0	RW	Bit				US
5.78	Field mode	0 to 2 (IntrnL (0), EtrnL (1) and E FULL (2))	IntrnL (0)	RW	Txt				US
5.79	Field economy active	0 to 1		RO	Bit				
5.80	Field economy level select	OFF (0) or On (1)	OFF (0)	RW	Bit				US
5.81	Field thermal time constant	0.0 to 3000.0	24.0	RW	Uni				US
5.82	Field overload accumulator	0 to 100.0 %		RO	Uni		NC	PT	
5.83	Field reversal enable	0 to ONLY_2_QUADRANT	0	RW	Uni		RA		US
5.84	Field flux threshold	0 to 100 %	75 %	RW	Uni				US
5.85	Flux demand invert	0 to 1		RO	Bit		NC	PT	
5.86	Speed error invert	0 to 1		RO	Bit		NC	PT	
5.87	Field IR compensation	0 to 100.0 %	100.0 %	RW	Uni				US
5.88	Armature IR compensation	±100.0 %	100.0 %	RW	Uni				US
5.89	External Flux feedback	0 to 100.0 %		RW	Uni		NC		

RW	Read / Write	RO	Read only	Uni	Unipolar	Bi	Bi-polar	Bit	Bit parameter	Txt	Text string		
FI	Filtered	DE	Destination	NC	Not copied	RA	Rating dependent	PT	Protected	US	User save	PS	Power down save

## 11.6 Menu 6: Sequencer and clock

Figure 11-7 Menu 6 logic diagram

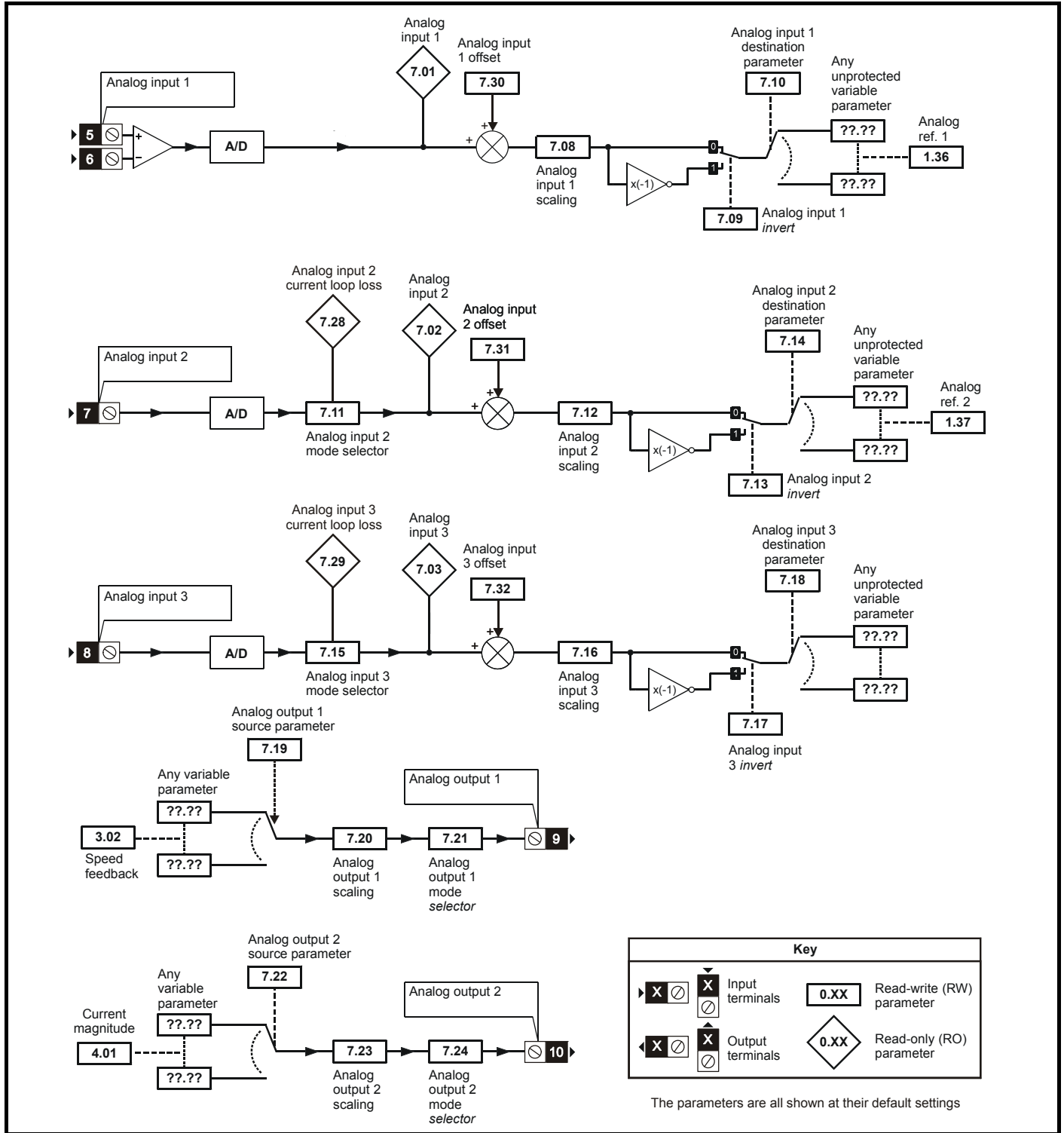


Parameter		Range(⇅)	Default(⇔)	Type			
6.01	Stop mode	0 to 2	1	RW	Uni		US
6.03	Main loss ride through	0 to 2 (diS, StoP, ridEth)	0	RW	Uni		US
6.04	Start/stop logic select	0 to 4	4	RW	Uni		US
6.08	Hold zero speed	OFF (0) or On (1)	OFF (0)	RW	Bit		US
6.09	Catch a spinning motor	0 to 1	1	RW	Uni		US
6.12	Enable stop key	OFF (0) or On (1)	OFF (0)	RW	Bit		US
6.13	Enable forward/reverse key	0 to 2	0	RW	Uni		US
6.15	Drive enable	OFF (0) or On (1)	On (1)	RW	Bit		US
6.16	Electricity cost per kWh	0.0 to 600.0 currency units per kWh	0.0	RW	Uni		US
6.17	Reset energy meter	OFF (0) or On (1)	OFF (0)	RW	Bit	NC	
6.18	Time between filter changes	0 to 30,000 hrs	0	RW	Uni		US
6.19	Filter change required / change done	OFF (0) or On (1)	OFF (0)	RW	Bit		PT
6.20	Powered-up time: years.days	0 to 9.364 Years.Days		RW	Uni	NC	PT
6.21	Powered-up time: hours.minutes	0 to 23.59 Hours.Minutes		RW	Uni	NC	PT
6.22	Run time: years.days	0 to 9.364 Years.Days		RO	Uni	NC	PT PS
6.23	Run time: hours.minutes	0 to 23.59 Hours.Minutes		RO	Uni	NC	PT PS
6.24	Energy meter: MWh	±9999 MWh		RO	Bi	NC	PT PS
6.25	Energy meter: kWh	±999 kWh		RO	Bi	NC	PT PS
6.26	Running cost	±32000		RO	Bi	FI	NC PT
6.27	Time before filter change due	0 to 30,000 hrs		RO	Uni	NC	PT PS
6.28	Select clock for trip log time stamping		OFF (0)	RW	Bit		US
6.29	Hardware enable			RO	Bit	NC	PT
6.30	Sequencing bit: Run forward			RW	Bit	NC	
6.31	Sequencing bit: Jog			RW	Bit	NC	
6.32	Sequencing bit: Run/reverse			RW	Bit	NC	
6.33	Sequencing bit: Forward/reverse			RW	Bit	NC	
6.34	Sequencing bit: Run	OFF (0) or On (1)	OFF (0)	RW	Bit	NC	
6.35	Forward limit switch			RW	Bit	NC	
6.36	Reverse limit switch			RW	Bit	NC	
6.37	Sequencing bit: Jog reverse			RW	Bit	NC	
6.39	Sequencing bit: Not stop			RW	Bit	NC	
6.40	Enable sequencer latching			RW	Bit		US
6.41	Drive event flags	0 to 65535	0	RW	Uni	NC	
6.42	Control word	0 to 32767	0	RW	Uni	NC	
6.43	Control word enable	OFF (0) or On (1)	OFF (0)	RW	Bit		US
6.45	Force cooling fan to run at full speed			RW	Bit		US
6.50	Drive comms state	0 to 3		RO	Txt	NC	PT
6.52	Zero reference interlock	OFF (0) or On (1)	OFF (0)	RW	Bit		US
6.54	Run rising edge delay	0 to 25.0 s	0.3 s	RW	Uni		US
6.55	Contactora active	OFF (0) or On (1)		RO	Bit	NC	PT
6.56	Drive active falling edge delay	0 to 255 s	0 s	RW	Uni		US

RW	Read / Write	RO	Read only	Uni	Unipolar	Bi	Bi-polar	Bit	Bit parameter	Txt	Text string		
FI	Filtered	DE	Destination	NC	Not copied	RA	Rating dependent	PT	Protected	US	User save	PS	Power down save

## 11.7 Menu 7: Analog I/O

Figure 11-8 Menu 7 logic diagram



Parameter		Range(↕)	Default(⇔)	Type					
7.01	T5/6 analog input 1 {in02, 0.82}	±100.00 %		RO	Bi		NC	PT	
7.02	T7 analog input 2 {in03, 0.83}	±100.0 %		RO	Bi		NC	PT	
7.03	T8 analog input 3 {in04, 0.84}			RO	Bi		NC	PT	
7.04	Power circuit temperature	-128 °C to 127 °C		RO	Bi		NC	PT	
7.08	T5/6 analog input 1 scaling	0 to 40.000	1.000	RW	Uni				US
7.09	T5/6 analog input 1 invert	OFF (0) to On (1)	OFF (0)	RW	Bit				US
7.10	T5/6 analog input 1 destination	Pr 0.00 to 22.99	Pr 1.36	RW	Uni			PT	US
7.11	T7 analog input 2 mode	0 to 6	6	RW	Uni				US
7.12	T7 analog input 2 scaling	0 to 40.000	1.000	RW	Uni				US
7.13	T7 analog input 2 invert	OFF (0) to On (1)	OFF (0)	RW	Bit				US
7.14	T7 analog input 2 destination	Pr 0.00 to 22.99	Pr 1.37	RW	Uni			PT	US
7.15	T8 analog input 3 mode {in01, 0.81}	0 to 9	Eur: 8, USA: 6	RW	Txt				US
7.16	T8 analog input 3 scaling	0 to 40.000	1.000	RW	Uni				US
7.17	T8 analog input 3 invert	OFF (0) to On (1)	OFF (0)	RW	Bit				US
7.18	T8 analog input 3 destination	Pr 0.00 to 22.99	Pr 0.00	RW	Uni			PT	US
7.19	T9 analog output 1 source		Pr 3.02	RW	Uni			PT	US
7.20	T9 analog output 1 scaling	0.000 to 40.000	1.000	RW	Uni				US
7.21	T9 analog output 1 mode	0 to 3	0	RW	Txt				US
7.22	T10 analog output 2 source	Pr 0.00 to 22.99	Pr 4.02	RW	Uni			PT	US
7.23	T10 analog output 2 scaling	0.000 to 40.000	1.000	RW	Uni				US
7.24	T10 analog output 2 mode	0 to 3	0	RW	Txt				US
7.28	T7 analog input current loop loss 2			RO	Bit		NC	PT	
7.29	T8 analog input current loop loss 3	OFF (0) to On (1)		RO	Bit		NC	PT	
7.30	T5/6 analog input 1 offset	±100.00 %	0.00	RW	Bi				US
7.31	T7 analog input 2 offset	±100.0 %	0.0	RW	Bi				US
7.32	T8 analog input 3 offset			RW	Bi				US
7.34	SCR / Thyristor junction temperature	0 to 150 °C		RO	Uni		NC	PT	

RW	Read / Write	RO	Read only	Uni	Unipolar	Bi	Bi-polar	Bit	Bit parameter	Txt	Text string		
FI	Filtered	DE	Destination	NC	Not copied	RA	Rating dependent	PT	Protected	US	User save	PS	Power down save



## 11.8 Menu 8: Digital I/O

Figure 11-9 Menu 8 logic diagram

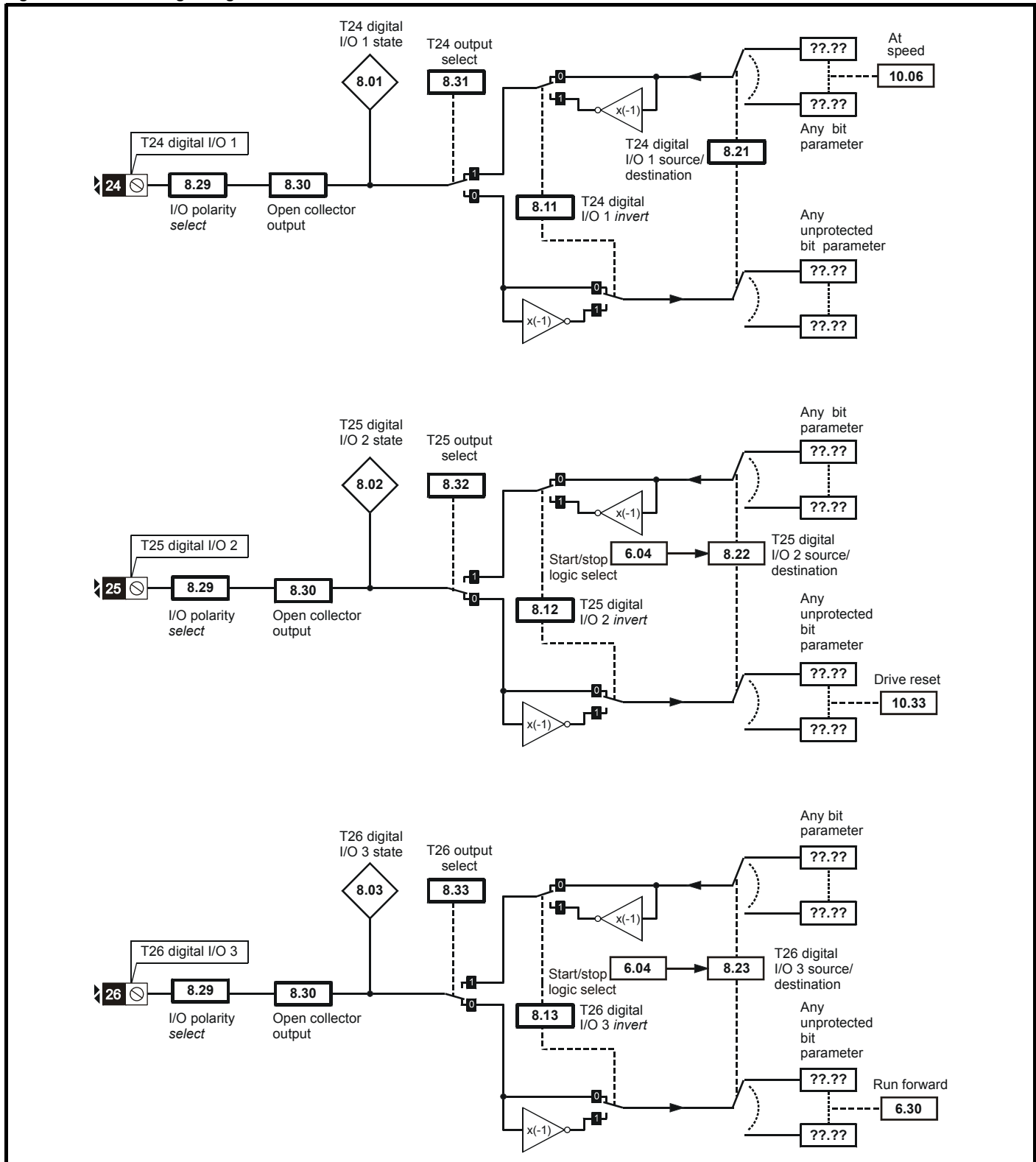


Figure 11-10 Menu 8 logic diagram (cont)

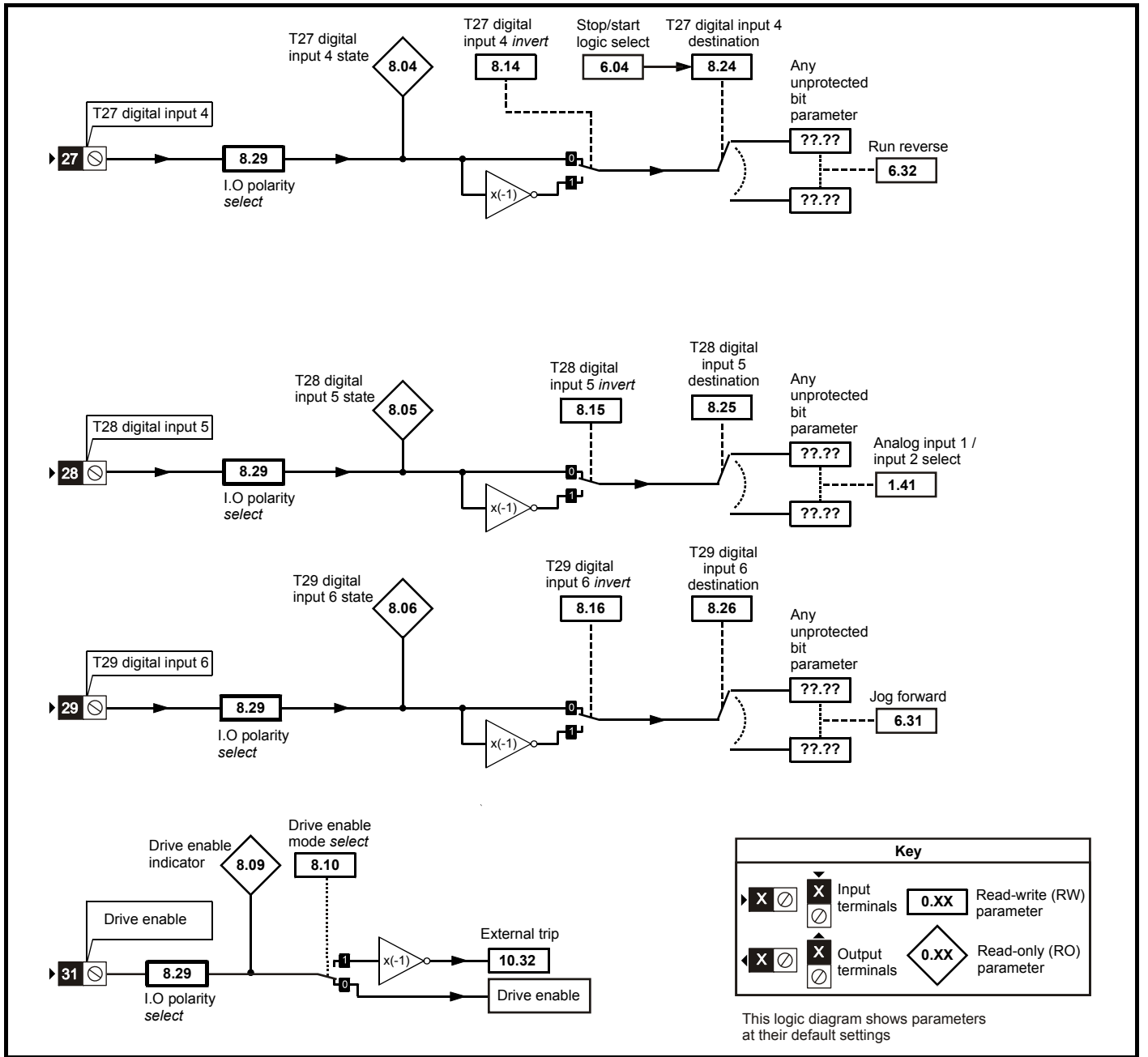
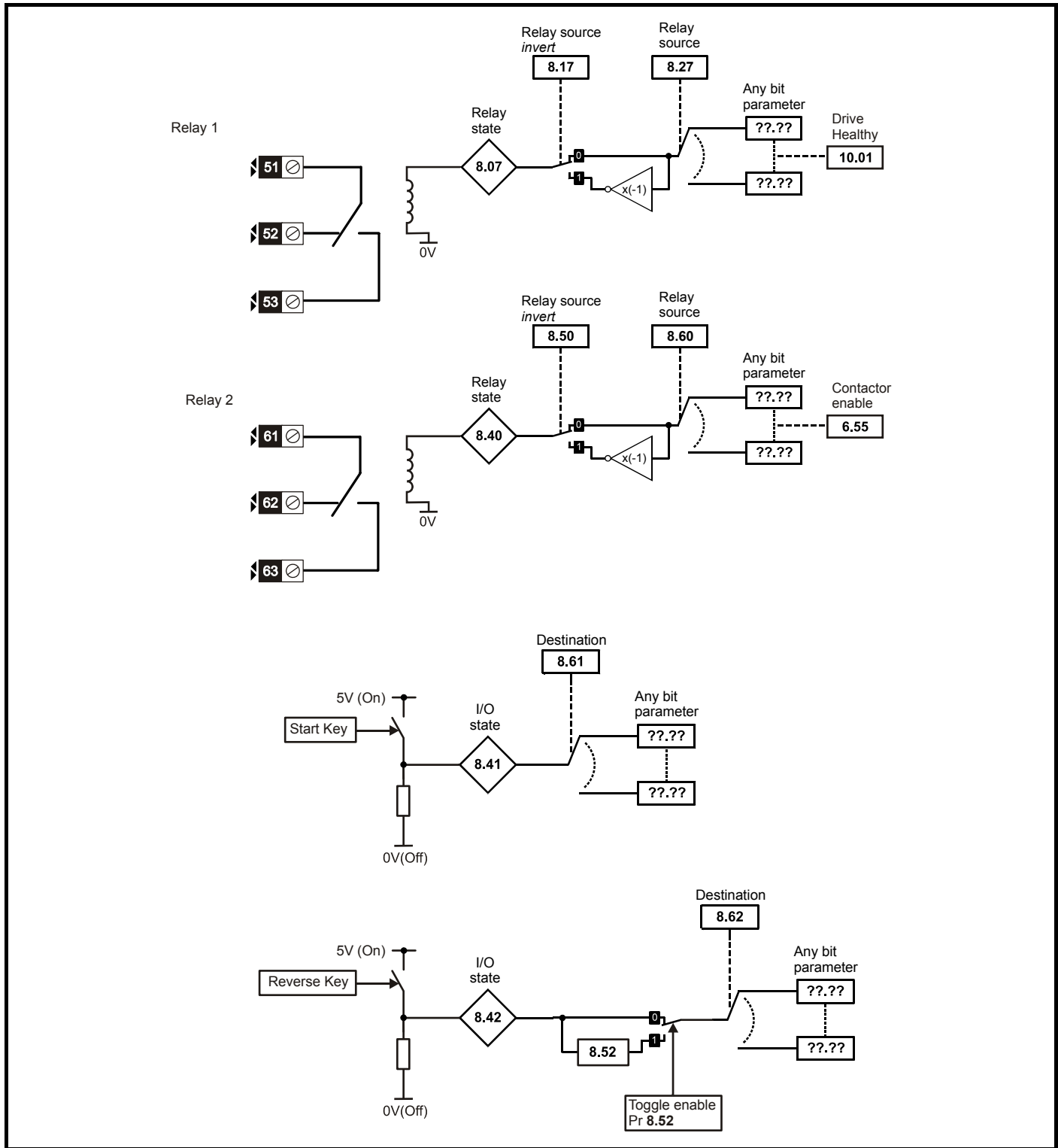


Figure 11-11 Menu 8 logic diagram (cont)

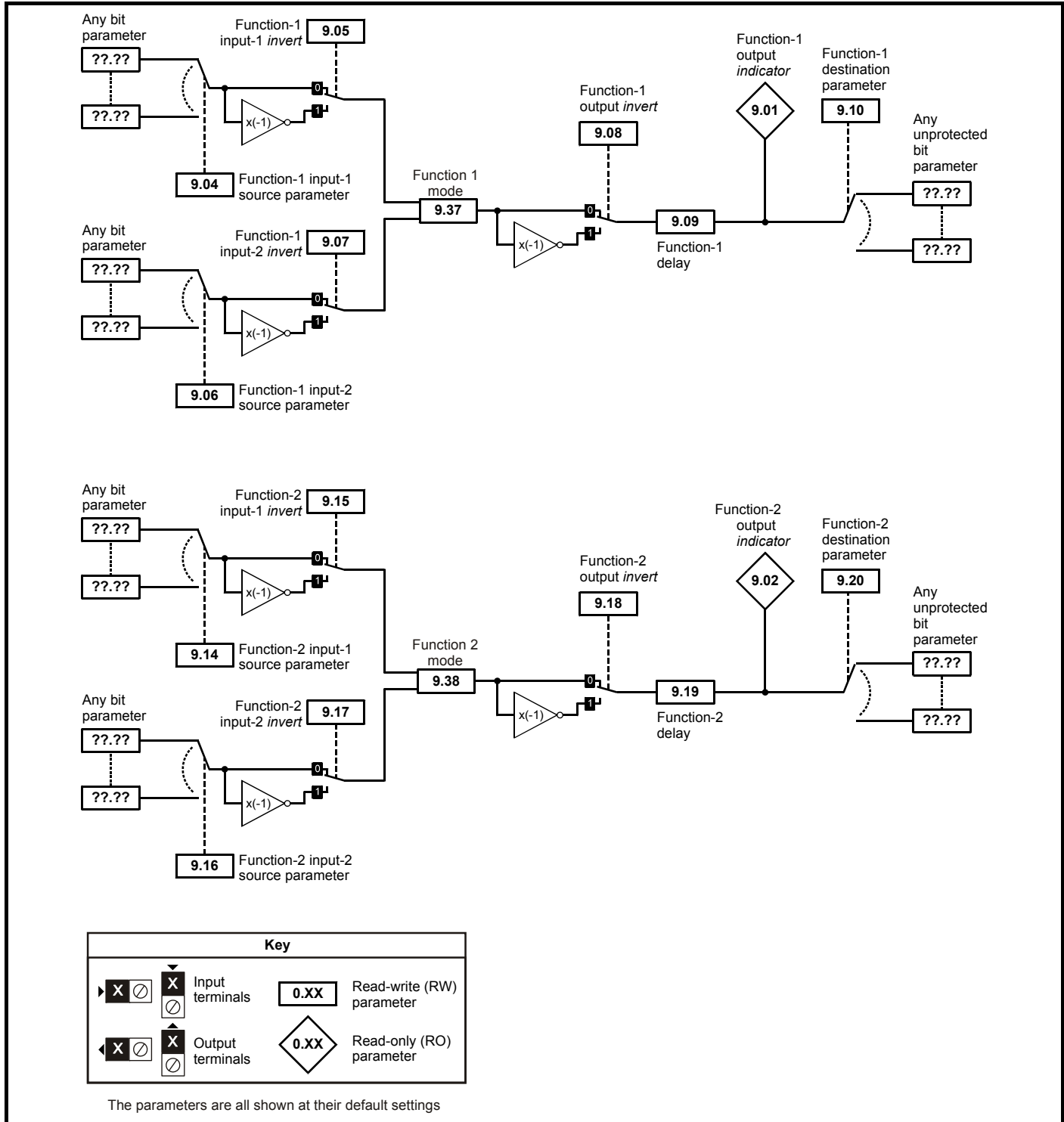


Parameter		Range(⇅)	Default(⇔)	Type						
8.01	T24 digital I/O 1 state {in05, 0.85}	OFF (0) or On (1)		RO	Bit		NC	PT		
8.02	T25 digital I/O 2 state {in06, 0.86}			RO	Bit		NC	PT		
8.03	T26 digital I/O 3 state {in07, 0.87}			RO	Bit		NC	PT		
8.04	T27 digital input 4 state {in08, 0.88}			RO	Bit		NC	PT		
8.05	T28 digital input 5 state {in09, 0.89}			RO	Bit		NC	PT		
8.06	T29 digital input 6 state {in10, 0.90}			RO	Bit		NC	PT		
8.07	T51, 52, 53 relay state			RO	Bit		NC	PT		
8.09	T31 drive enable state			RO	Bit		NC	PT		
8.10	Enable mode select			0 to 2	0	RW	Uni			
8.11	T24 digital I/O 1 invert	OFF (0) or On (1)	OFF (0)	RW	Bit				US	
8.12	T25 digital I/O 2 invert			RW	Bit				US	
8.13	T26 digital I/O 3 invert			RW	Bit				US	
8.14	T27 digital input 4 invert			RW	Bit				US	
8.15	T28 digital input 5 invert			RW	Bit				US	
8.16	T29 digital input 6 invert			RW	Bit				US	
8.17	T51, 52, 53 relay invert			RW	Bit				US	
8.20	Digital I/O read word	0 to 4095		RO	Uni		NC	PT		
8.21	T24 digital I/O 1 source/ destination	Pr 0.00 to 22.99	Pr 10.06	RW	Uni	DE		PT	US	
8.22	T25 digital I/O 2 source/ destination		Pr 10.33	RW	Uni	DE		PT	US	
8.23	T26 digital I/O 3 source/ destination		Pr 6.30	RW	Uni	DE		PT	US	
8.24	T27 digital input 4 destination		Pr 6.32	RW	Uni	DE		PT	US	
8.25	T28 digital input 5 destination		Pr 1.41	RW	Uni	DE		PT	US	
8.26	T29 digital input 6 destination		Pr 6.31	RW	Uni	DE		PT	US	
8.27	T51, 52, 53 relay source		Pr 10.01	RW	Uni			PT	US	
8.29	I/O polarity select	2	1	RW	Uni			PT	US	
8.30	Open collector output	OFF (0) or On (1)	OFF (0)	RW	Bit				US	
8.31	T24 digital I/O 1 output select		On (1)	RW	Bit				US	
8.32	T25 digital I/O 2 output select		OFF (0)		RW	Bit				US
8.33	T26 digital I/O 3 output select				RW	Bit				US
8.40	T61, 62, 63 relay state		RO	Bit		NC	PT			
8.41	Start button state		RO	Bit		NC	PT			
8.42	Forward/reverse button state		OFF (0)	RO	Bit		NC	PT		
8.48	24V input state		RO	Bit		NC	PT			
8.50	T61, 62, 63 relay invert		OFF (0)	RW	Bit				US	
8.52	Toggle enable		RW	Bit					US	
8.60	T61, 62, 63 relay source	Pr 6.55	RW	Uni	DE		PT	US		
8.61	Start button destination	Pr 0.00 to 22.99	Pr 0.00	RW	Uni	DE		PT	US	
8.62	Forward/reverse button destination			RW	Uni	DE		PT	US	

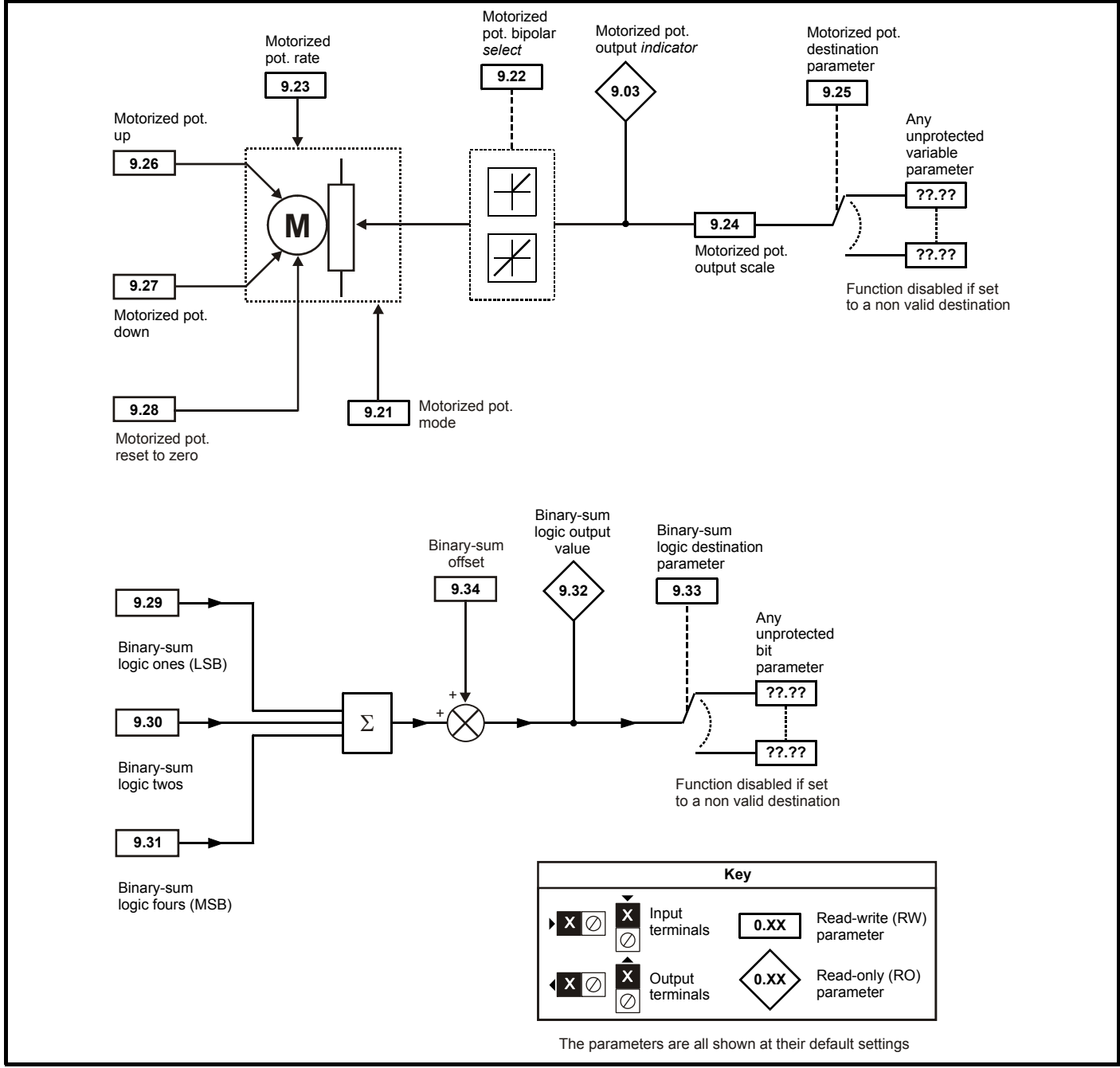
RW	Read / Write	RO	Read only	Uni	Unipolar	Bi	Bi-polar	Bit	Bit parameter	Txt	Text string		
FI	Filtered	DE	Destination	NC	Not copied	RA	Rating dependent	PT	Protected	US	User save	PS	Power down save

## 11.9 Menu 9: Programmable logic, motorized pot and binary sum

Figure 11-12 Menu 9 logic diagram: Programmable logic



**Figure 11-13 Menu 9 logic diagram: Motorized potentiometer and binary sum**



Parameter		Range(⇅)	Default(⇨)	Type					
9.01	Logic function 1 output	OFF (0) or On (1)		RW	Bit		NC	PT	
9.02	Logic function 2 output			RW	Bit		NC	PT	
9.03	Motorized pot output	±100.00 %		RW	Bit		NC	PT	PS
9.04	Logic function 1 source 1	Pr 0.00 to 22.99	Pr 0.00	RW	Uni			PT	US
9.05	Logic function 1 source 1 invert	OFF (0) or On (1)	OFF (0)	RW	Bit				US
9.06	Logic function 1 source 2	Pr 0.00 to 22.99	Pr 0.00	RW	Uni			PT	US
9.07	Logic function 1 source 2 invert	OFF (0) or On (1)	OFF (0)	RW	Bit				US
9.08	Logic function 1 output invert	OFF (0) or On (1)	OFF (0)	RW	Bit				US
9.09	Logic function 1 delay	±25.0 s	0.0 s	RW	Bi				US
9.10	Logic function 1 destination	Pr 0.00 to 22.99	Pr 0.00	RW	Uni			PT	US
9.14	Logic function 2 source 1	Pr 0.00 to 22.99	Pr 0.00	RW	Uni			PT	US
9.15	Logic function 2 source 1 invert	OFF (0) or On (1)	OFF (0)	RW	Bit				US
9.16	Logic function 2 source 2	Pr 0.00 to 22.99	Pr 0.00	RW	Uni			PT	US
9.17	Logic function 2 source 2 invert	OFF (0) or On (1)	OFF (0)	RW	Bit				US
9.18	Logic function 2 output invert	OFF (0) or On (1)	OFF (0)	RW	Bit				US
9.19	Logic function 2 delay	±25.0 s	0.0 s	RW	Bi				US
9.20	Logic function 2 destination	Pr 0.00 to 22.99	Pr 0.00	RW	Uni			PT	US
9.21	Motorized pot mode	0 to 3	2	RW	Uni				US
9.22	Motorized pot bipolar select	OFF (0) or On (1)	OFF (0)	RW	Bit				US
9.23	Motorized pot rate	0 to 250 s	20 s	RW	Uni				US
9.24	Motorized pot scale factor	0 to 4.000	1.000	RW	Uni				US
9.25	Motorized pot destination	Pr 0.00 to 22.99	Pr 0.00	RW	Uni			PT	US
9.26	Motorized pot up	OFF (0) or On (1)	OFF (0)	RW	Bit		NC		
9.27	Motorized pot down			RW	Bit		NC		
9.28	Motorized pot reset			RW	Bit		NC		
9.29	Binary sum ones input			RW	Bit		NC		
9.30	Binary sum twos input			RW	Bit		NC		
9.31	Binary sum fours input			RW	Bit		NC		
9.32	Binary sum output	0 to 255		RO	Uni		NC	PT	
9.33	Binary sum destination	Pr 0.00 to 22.99	Pr 0.00	RW	Uni			PT	US
9.34	Binary sum offset	0 to 248	0	RW	Uni				US
9.35	Up down disable source	Pr 0.00 to 22.99	Pr 0.00	RW	Uni			PT	US
9.36	Up down disable invert	OFF (0) or On (1)	OFF (0)	RW	Bit				US
9.37	Logic block 1 mode	0 to 4	0	RW	Uni				US
9.38	Logic block 2 mode			RW	Uni				US

RW	Read / Write	RO	Read only	Uni	Unipolar	Bi	Bi-polar	Bit	Bit parameter	Txt	Text string		
FI	Filtered	DE	Destination	NC	Not copied	RA	Rating dependent	PT	Protected	US	User save	PS	Power down save

## 11.10 Menu 10: Status and trips

Parameter		Range(⇅)	Default(⇄)	Type						
10.01	Drive ok	OFF (0) or On (1)		RO	Bit	NC	PT			
10.02	Drive active			RO	Bit	NC	PT			
10.03	Zero speed			RO	Bit	NC	PT			
10.04	Running at or below min speed			RO	Bit	NC	PT			
10.05	Below set speed			RO	Bit	NC	PT			
10.06	At speed			RO	Bit	NC	PT			
10.07	Above set speed			RO	Bit	NC	PT			
10.08	Load reached			RO	Bit	NC	PT			
10.09	Drive output is at current limit			RO	Bit	NC	PT			
10.10	Regenerating			RO	Bit	NC	PT			
10.13	Direction command			RO	Bit	NC	PT			
10.14	Direction running			RO	Bit	NC	PT			
10.17	Overload alarm			RO	Bit	NC	PT			
10.18	Drive over temperature alarm			RO	Bit	NC	PT			
10.19	Drive warning			RO	Bit	NC	PT			
10.20	Trip 0 {tr01, 0.51}			0 to 229		RO	Txt	NC	PT	PS
10.21	Trip 1 {tr02, 0.52}					RO	Txt	NC	PT	PS
10.22	Trip 2 {tr03, 0.53}					RO	Txt	NC	PT	PS
10.23	Trip 3 {tr04, 0.54}					RO	Txt	NC	PT	PS
10.24	Trip 4 {tr05, 0.55}	RO	Txt			NC	PT	PS		
10.25	Trip 5 {tr06, 0.56}	RO	Txt			NC	PT	PS		
10.26	Trip 6 {tr07, 0.57}	RO	Txt			NC	PT	PS		
10.27	Trip 7 {tr08, 0.58}	RO	Txt			NC	PT	PS		
10.28	Trip 8 {tr09, 0.59}	RO	Txt			NC	PT	PS		
10.29	Trip 9 {tr10, 0.60}	RO	Txt			NC	PT	PS		
10.32	External trip	OFF (0) or On (1)	OFF (0)	RW	Bit	NC				
10.33	Drive reset			RW	Bit	NC				
10.34	Number of auto-reset attempts	0 to 5	0	RW	Uni			US		
10.35	Auto-reset delay	0 to 25.0 s	1.0 s	RW	Uni			US		
10.36	Hold drive ok until last attempt	OFF (0) or On (1)	OFF (0)	RW	Bit			US		
10.38	User trip	0 to 255	0	RW	Uni	NC				
10.40	Status word	0 to 32767		RO	Uni	NC	PT			
10.41	Trip 0 time: Years.Days	0 to 9.364 Years.Days		RO	Uni	NC	PT	PS		
10.42	Trip 0 time: Hours.Minutes	0 to 23.59 Hours.Minutes		RO	Uni	NC	PT	PS		
10.43	Trip 1 time: Hours.Minutes	0 to 600.00 Hours.Minutes		RO	Uni	NC	PT	PS		
10.44	Trip 2 time: Hours.Minutes			RO	Uni	NC	PT	PS		
10.45	Trip 3 time: Hours.Minutes			RO	Uni	NC	PT	PS		
10.46	Trip 4 time: Hours.Minutes			RO	Uni	NC	PT	PS		
10.47	Trip 5 time: Hours.Minutes			RO	Uni	NC	PT	PS		
10.48	Trip 6 time: Hours.Minutes			RO	Uni	NC	PT	PS		
10.49	Trip 7 time: Hours.Minutes			RO	Uni	NC	PT	PS		
10.50	Trip 8 time: Hours.Minutes			RO	Uni	NC	PT	PS		
10.51	Trip 9 time: Hours.Minutes			RO	Uni	NC	PT	PS		
10.52	Trip mask 0	0 to 216	0	RW	Uni			US		
10.53	Trip mask 1			RW	Uni			US		
10.54	Trip mask 2			RW	Uni			US		
10.55	Trip mask 3			RW	Uni			US		
10.56	Trip mask 4			RW	Uni			US		
10.57	Trip mask 5			RW	Uni			US		
10.58	Trip mask 6			RW	Uni			US		
10.59	Trip mask 7			RW	Uni			US		
10.60	Trip mask 8			RW	Uni			US		
10.61	Trip mask 9	RW	Uni			US				
10.62	Stop on trip mask 0	OFF (0) or On (1)	On (1)	RW	Bit			US		
10.63	Stop on trip mask 1			RW	Bit			US		
10.64	Stop on trip mask 2			RW	Bit			US		
10.65	Stop on trip mask 3			RW	Bit			US		
10.66	Stop on trip mask 4			RW	Bit			US		
10.67	Stop on trip mask 5			RW	Bit			US		
10.68	Stop on trip mask 6			RW	Bit			US		
10.69	Stop on trip mask 7			RW	Bit			US		
10.70	Stop on trip mask 8			RW	Bit			US		
10.71	Stop on trip mask 9			RW	Bit			US		
10.72	Trip mask active			RO	Bit	NC				
10.73	Bridge active	0 to 2		RO	Txt	NC				
10.74	Electrical phase back	OFF (0) or On (1)		RO	Bit	NC				
10.75	Armature voltage clamp active			RO	Bit	NC				
10.76	Phase rotation	0 to 15		RO	Txt	NC				
10.77	Input frequency	0 to 100.00		RO	Uni	NC				



## 11.11 Menu 11: General drive set-up

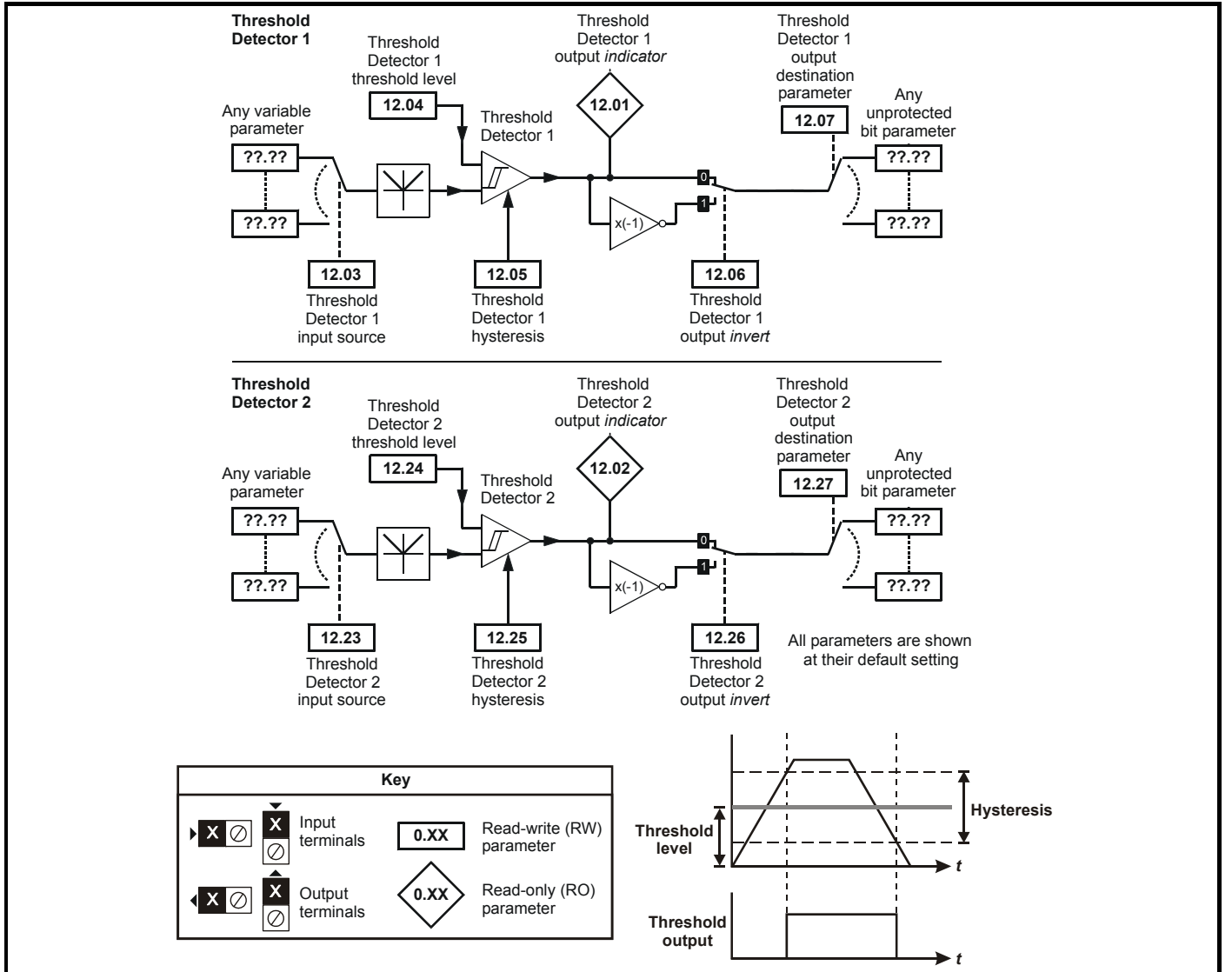
Parameter		Range(⇅)	Default(⇔)	Type					
11.21	Parameter scaling	0 to 9.999	1.000	RW	Uni				US
11.22	Parameter displayed at power-up	0 to 00.90	00.40	RW	Uni			PT	US
11.23	Serial address {Si02, 0.67}	0 to 247	1	RW	Uni				US
11.24	Serial mode	0 to 2	1	RW	Txt				US
11.25	Baud rate {Si01, 0.66}	0 to 9	6	RW	Txt				US
11.26	Minimum comms transmit delay	0 to 250 ms	2	RW	Uni				US
11.29	Software version {di14, 0.49}	1.0 to 99.99		RO	Uni		NC	PT	
11.30	User security code	0 to 999	0	RW	Uni		NC	PT	PS
11.32	Current rating	0 to 10000.0 A		RO	Uni		NC	PT	
11.33	Drive voltage rating	0 (480 V), 1 (575 V), 2 (690 V)		RO	Txt		NC	PT	
11.34	Software sub-version	0 to 99		RO	Uni		NC	PT	
11.35	Number of modules	0 to 3		RW	Uni			PT	US
11.36	SMARTCARD parameter data previously loaded	0 to 999	0	RO	Uni		NC	PT	US
11.37	SMARTCARD data number	0 to 1003		RW	Uni		NC		
11.38	SMARTCARD data type/ mode	0 to 18		RO	Uni		NC	PT	
11.39	SMARTCARD data version	0 to 9999	0	RW	Uni		NC		
11.40	SMARTCARD data checksum	0 to 65335		RO	Uni		NC	PT	
11.41	Status mode timeout	0 to 250 s	240	RW	Uni				US
11.42	Parameter copying {SE09, 0.30}	0 to 4	0	RW	Txt		NC		*
11.44	Security status {SE14, 0.35}	0 to 2	0	RW	Txt			PT	US
11.45	Select motor 2 parameters	OFF (0) or On (1)	OFF (0)	RW	Bit				US
11.46	Defaults previously loaded	0 to 2	0	RO	Txt			PT	US
11.47	Drive Onboard Application Lite Ladder Program Enable	0 to 2	2	RW	Uni				US
11.48	Drive Onboard Application Lite Ladder Program Status	-128 to +127		RO	Bi		NC	PT	
11.49	Drive Onboard Application Lite Ladder Program Events	0 to 65535		RO	Uni		NC	PT	PS
11.50	Drive Onboard Application Lite Ladder Program Maximum Scan Time	0 to 65535 ms		RO	Uni		NC	PT	
11.51	Drive Onboard Application Lite Ladder Program First Run	OFF (0) or On (1)		RO	Bit		NC	PT	
11.52	Drive serial number	0 to 999 999 999		RO	Uni		NC	PT	
11.53	Build location	0 to 255		RO	Uni		NC	PT	
11.55	Drive rating number	0 to 68		RO	Uni		NC	PT	
11.56	Power PCB software version	1.00 to 99.99		RO	Uni		NC	PT	
11.57	Serial programmable source	Pr 0.00 to 22.99	Pr 0.00	RW	Uni			PT	US
11.58	Serial scaling	0 to 1999	1000	RW	Uni				US
11.59	Mentor II Parameter Emulator Module Control	0 to 3	0	RW	Uni				US
11.60	Application parameters	16000 to -16000		RW	Uni		NC		
11.61	Application parameters			RW	Uni		NC		
11.62	Full power discharge time	0 to 25.0 s	0.0 s	RW	Uni				US
11.63	Full power discharge period	0 to 1500.0 s		RW	Uni				US
11.64	External discharge resistance	0 to 9999 Ω	0 Ω	RW	Uni				US
11.65	External resistor temperature	0 to 100 %		RO			NC	PT	
11.66	Suppressor voltage	0 to 2000 V		RO			NC	PT	

RW	Read / Write	RO	Read only	Uni	Unipolar	Bi	Bi-polar	Bit	Bit parameter	Txt	Text string		
FI	Filtered	DE	Destination	NC	Not copied	RA	Rating dependent	PT	Protected	US	User save	PS	Power down save

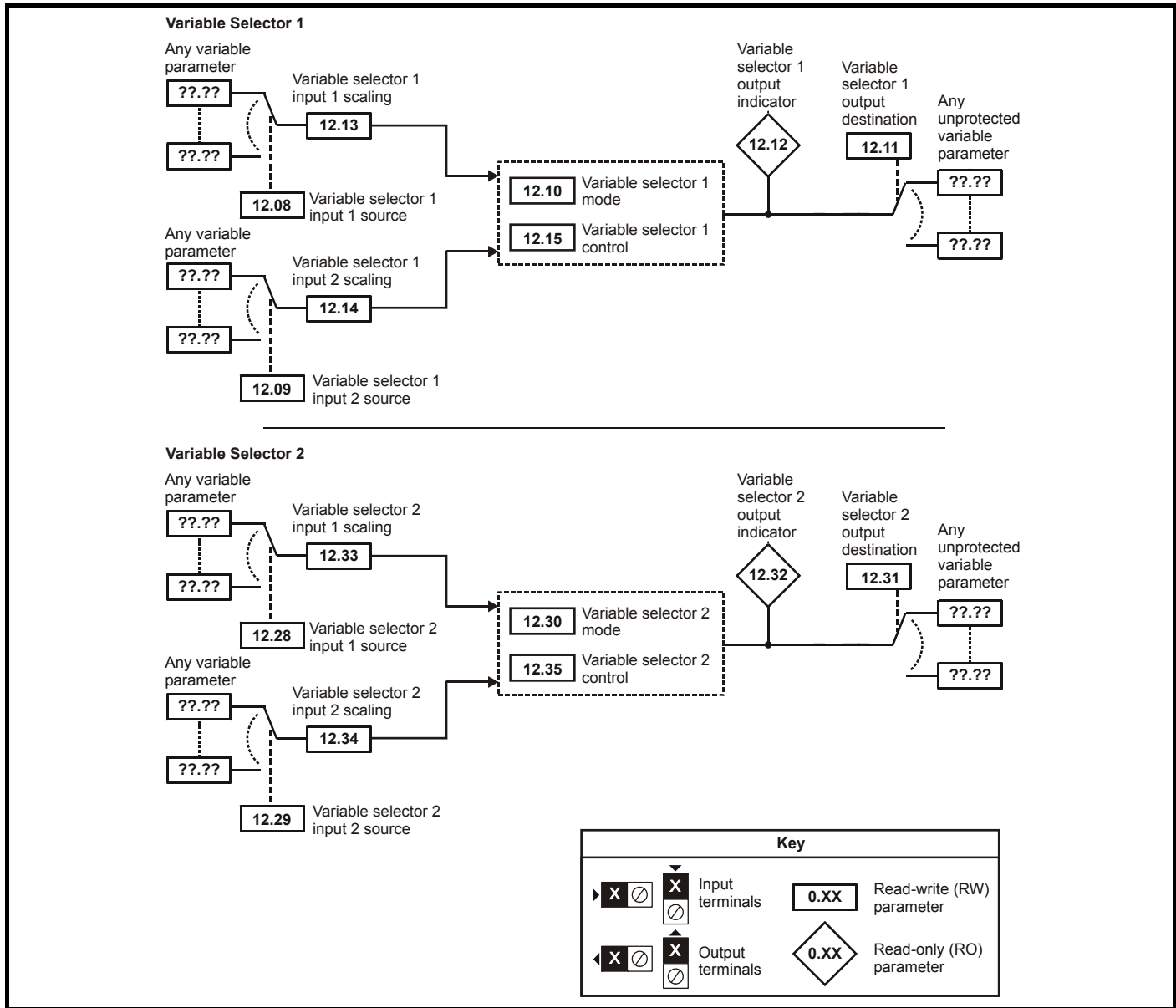
\* Modes 1 and 2 are not US (i.e. not saved when drive parameters are saved), mode 3 and 4 are US. Therefore this parameter can only be saved to EEPROM if it has a value of 0, 3 or 4.

## 11.12 Menu 12: Threshold detectors, variable selectors and brake control function

Figure 11-14 Menu 12 logic diagram



**Figure 11-15 Menu 12 logic diagram (continued)**



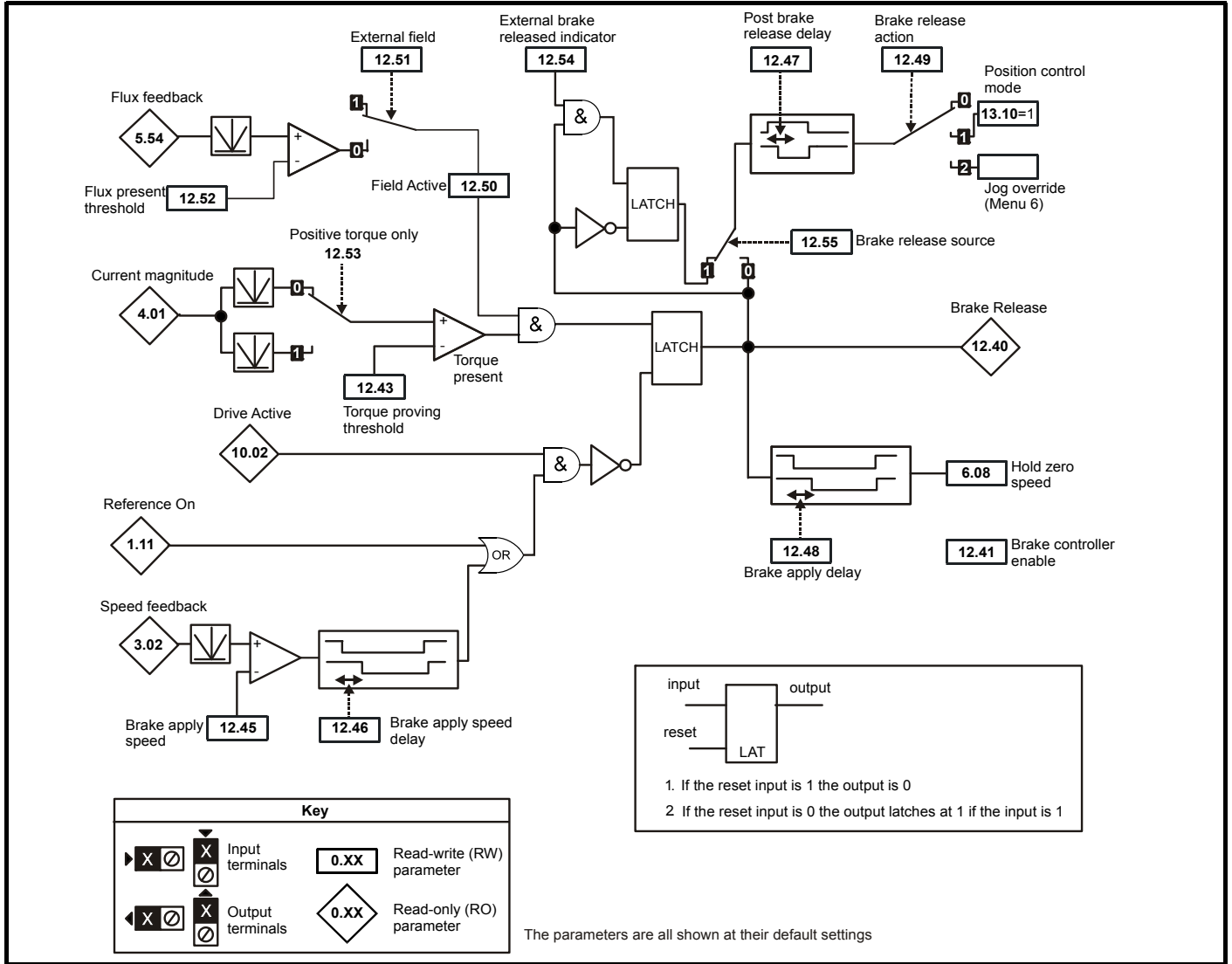


The brake control functions are provided to allow well co-ordinated operation of an external brake with the drive. While both hardware and software are designed to high standards of quality and robustness, they are not intended for use as safety functions, i.e. where a fault or failure would result in a risk of injury. In any application where the incorrect operation of the brake release mechanism could result in injury, independent protection devices of proven integrity must also be incorporated.

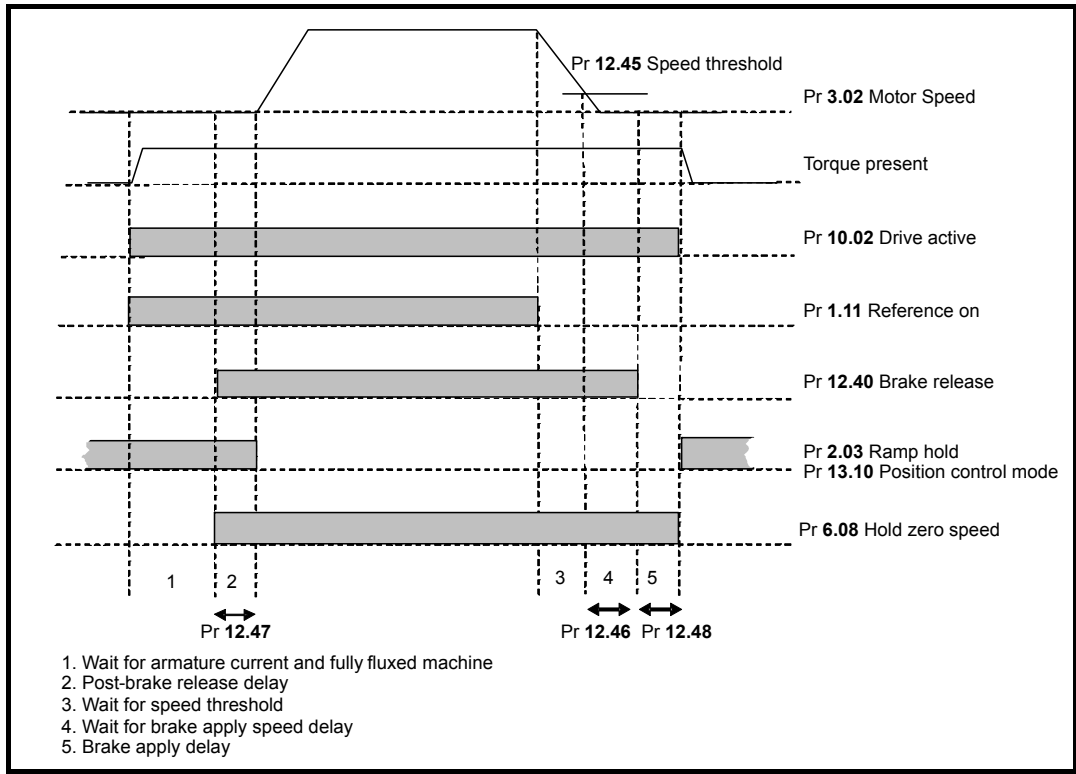


The control terminal relay can be selected as an output to release a brake. If a drive is set up in this manner and a drive replacement takes place, prior to programming the drive on initial power up, the brake may be released. When drive terminals are programmed to non default settings the result of incorrect or delayed programming must be considered. The use of a SMARTCARD in boot mode or an SM-Applications module can ensure drive parameters are immediately programmed to avoid this situation.

**Figure 11-16 Menu 12 Brake control function**



**Figure 11-17 Brake sequence**



Parameter		Range(⇅)	Default(⇒)	Type					
12.01	Threshold detector 1 output	OFF (0) or On (1)		RO	Bit		NC	PT	
12.02	Threshold detector 2 output			RO	Bit		NC	PT	
12.03	Threshold detector 1 source	Pr 0.00 to 22.99	Pr 0.00	RW	Uni				PT US
12.04	Threshold detector 1 level	0 to 100.00 %	0.00	RW	Uni				US
12.05	Threshold detector 1 hysteresis	0 to 25.00 %		RW	Uni				US
12.06	Threshold detector 1 output invert	OFF (0) or On (1)	OFF (0)	RW	Bit				US
12.07	Threshold detector 1 destination	Pr 0.00 to 22.99	Pr 0.00	RW	Uni				PT US
12.08	Variable selector 1 source 1			RW	Uni				PT US
12.09	Variable selector 1 source 2			RW	Uni				PT US
12.10	Variable selector 1 mode	0 to 10	0	RW	Uni				US
12.11	Variable selector 1 destination	Pr 0.00 to 22.99	Pr 0.00	RW	Uni				PT US
12.12	Variable selector 1 output	±100.00 %		RO	Uni		NC	PT	
12.13	Variable selector 1 source 1 scaling	±4.000	1.000	RW	Uni				US
12.14	Variable selector 1 source 2 scaling			RW	Uni				US
12.15	Variable selector 1 control	0 to 100.00	0.00	RW	Uni				US
12.23	Threshold detector 2 source	Pr 0.00 to 22.99	Pr 0.00	RW	Uni				PT US
12.24	Threshold detector 2 level	0 to 100.00 %	0.00	RW	Uni				US
12.25	Threshold detector 2 hysteresis	0 to 25.00 %		RW	Uni				US
12.26	Threshold detector 2 output invert	OFF (0) or On (1)	OFF (0)	RW	Bit				US
12.27	Threshold detector 2 destination	Pr 0.00 to 22.99	Pr 0.00	RW	Uni				PT US
12.28	Variable selector 2 source 1			RW	Uni				PT US
12.29	Variable selector 2 source 2			RW	Uni				PT US
12.30	Variable selector 2 mode	0 to 10	0	RW	Uni				US
12.31	Variable selector 2 destination	Pr 0.00 to 22.99	Pr 0.00	RW	Uni				PT US
12.32	Variable selector 2 output	±100.00 %		RO	Uni		NC	PT	
12.33	Variable selector 2 source 1 scaling	±4.000	1.000	RW	Uni				US
12.34	Variable selector 2 source 2 scaling			RW	Uni				US
12.35	Variable selector 2 control	0 to 100.00	0.00	RW	Uni				US



The brake control functions are provided to allow well co-ordinated operation of an external brake with the drive. While both hardware and software are designed to high standards of quality and robustness, they are not intended for use as safety functions, i.e. where a fault or failure would result in a risk of injury. In any application where the incorrect operation of the brake release mechanism could result in injury, independent protection devices of proven integrity must also be incorporated.

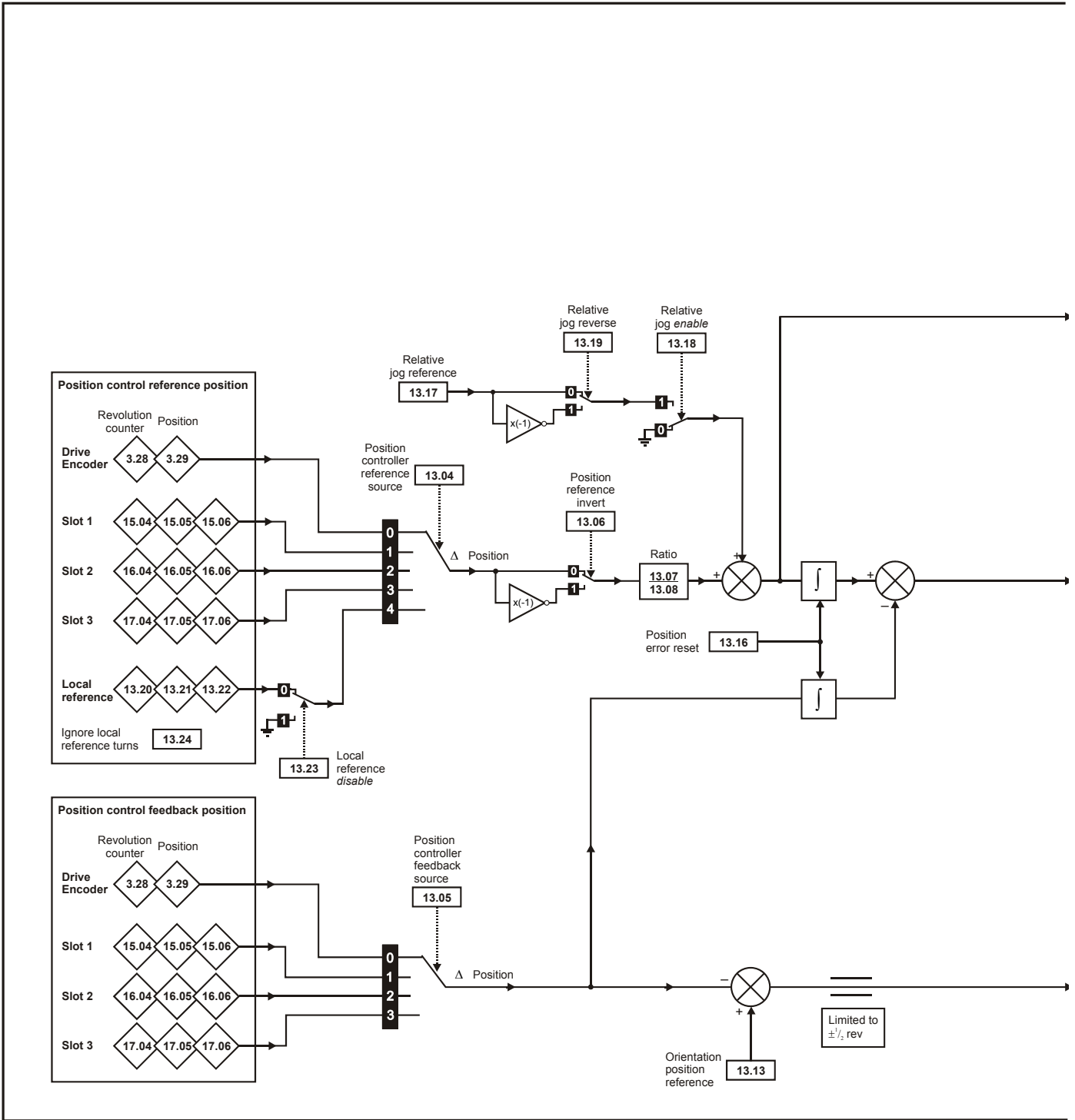
12.40	Brake release	OFF (0) or On (1)		RO	Uni		NC	PT	
12.41	Brake controller enable	0 to 3	0	RW	Txt				US
12.43	Torque proving threshold	0 to 150 %	10 %	RW	Uni				US
12.45	Brake apply speed	0 to 200 rpm	5 rpm	RW	Uni				US
12.46	Brake apply speed delay	0 to 25.0 s	1.0 s	RW	Uni				US
12.47	Post-brake release delay			RW	Uni				US
12.48	Brake apply delay			RW	Uni				US
12.49	Brake release action	OFF (0) or On (1)	OFF (0)	RW	Uni				US
12.50	Field active			RW	Bit				US
12.51	External field control			RW	Bit				US
12.52	Flux present threshold	0 to 100 %	80 %	RW					US
12.53	Positive torque proving only	OFF (0) or On (1)	OFF (0)	RW	Bit				US
12.54	External brake released indicator	OFF (0) or On (1)	OFF (0)	RW	Bit		NC		
12.55	Brake release action source	OFF (0) or On (1)	OFF (0)	RW	Bit				US

RW	Read / Write	RO	Read only	Uni	Unipolar	Bi	Bi-polar	Bit	Bit parameter	Txt	Text string		
FI	Filtered	DE	Destination	NC	Not copied	RA	Rating dependent	PT	Protected	US	User save	PS	Power down save

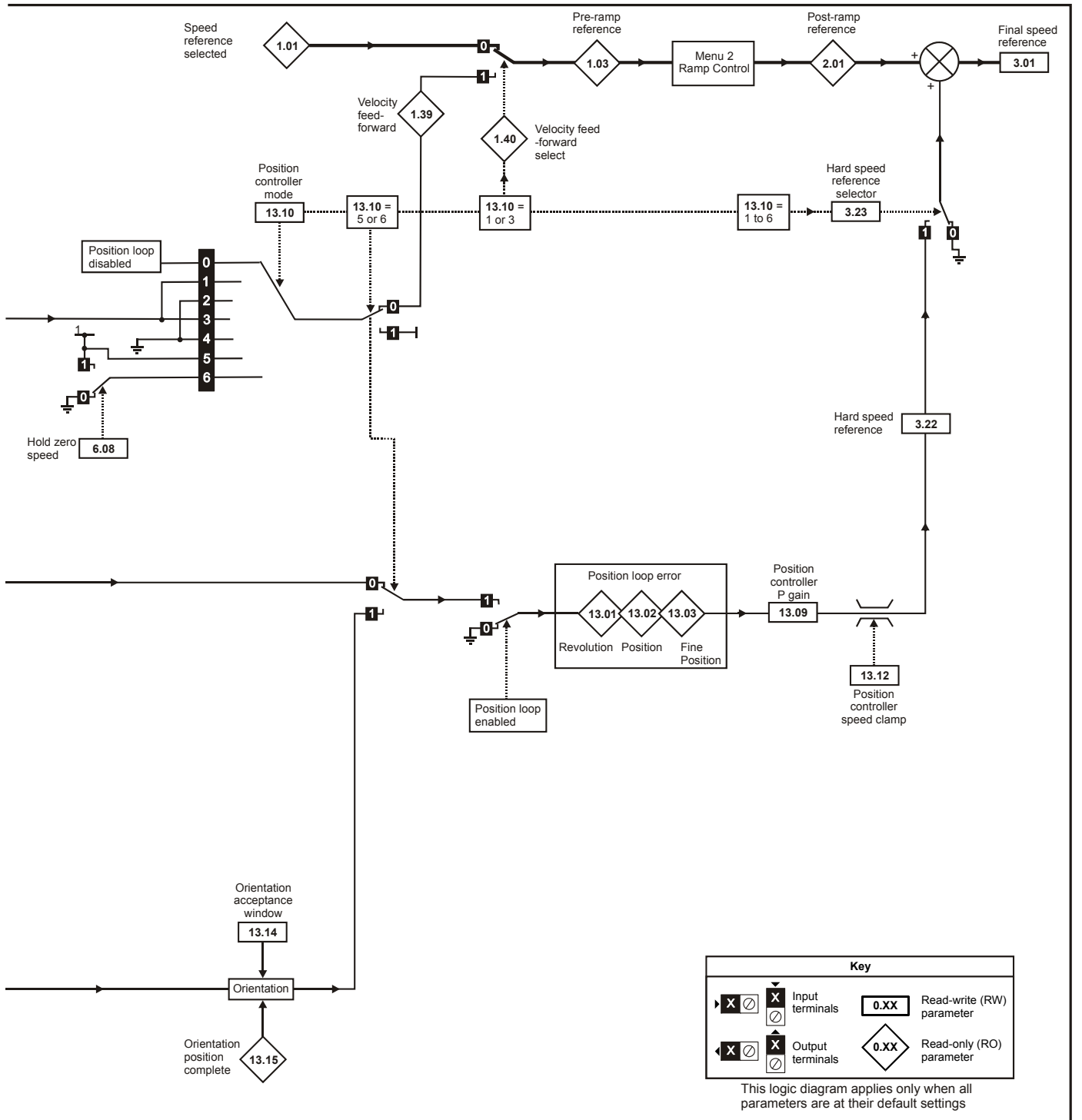


## 11.13 Menu 13: Position control

Figure 11-18 Menu 13 logic diagram







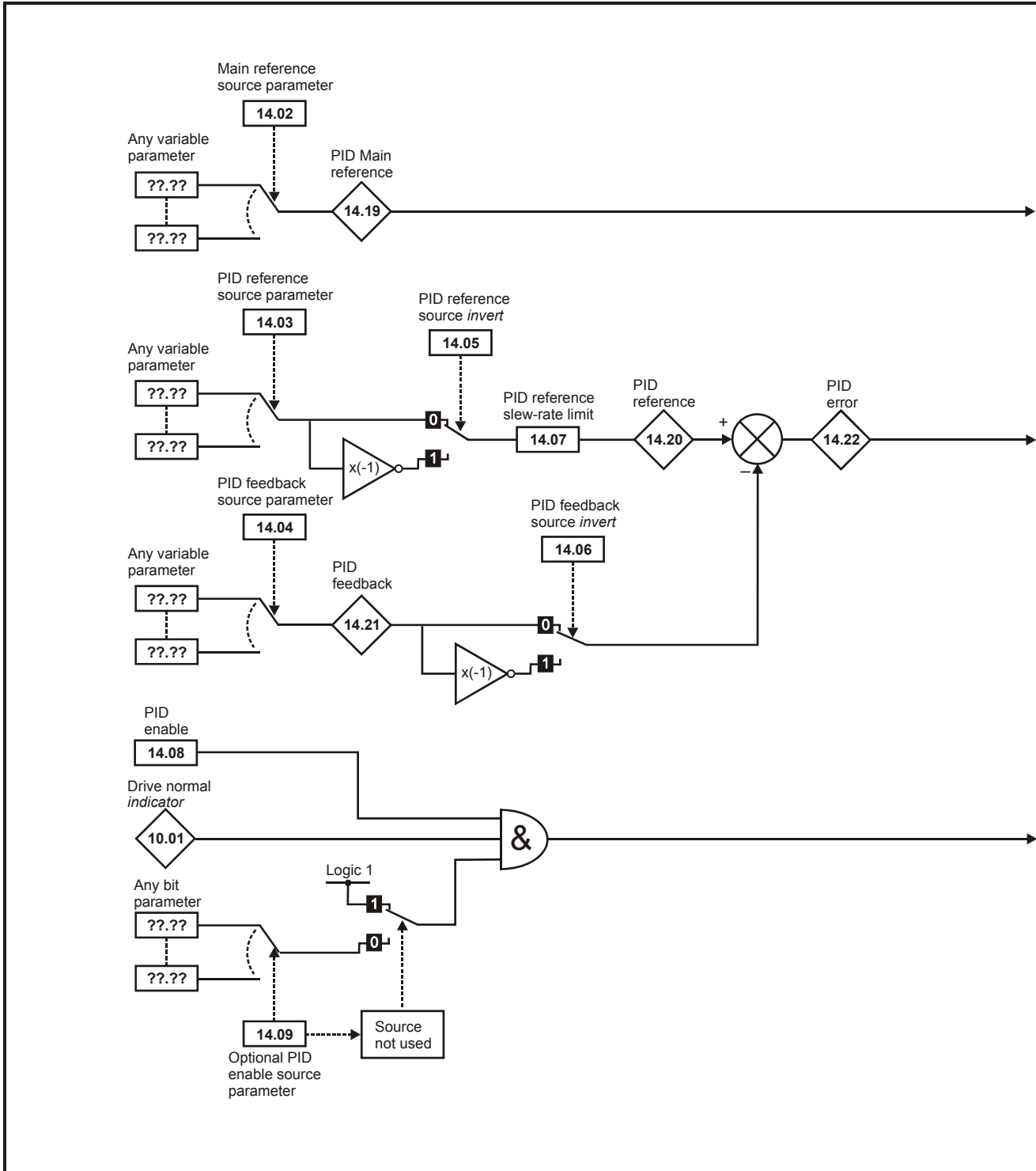
Parameter		Range(⇅)	Default(⇔)	Type			
13.01	Revolutions error	-32768 to +32767		RO	Uni	NC	PT
13.02	Position error	-32768 to +32767		RO	Uni	NC	PT
13.03	Fine position error	-32768 to +32767		RO	Uni	NC	PT
13.04	Position controller reference source	0 to 4	0	RW	Txt		US
13.05	Position controller feedback source	0 to 3	0	RW	Txt		US
13.06	Position reference invert	OFF (0) or On(1)	OFF (0)	RW	Bit		US
13.07	Ratio numerator	0 to 4.000	1.000	RW	Uni		US
13.08	Ration denominator	0 to 1.000	1.000	RW	Uni		US
13.09	Position controller P gain	0 to 100.00 rads <sup>-1</sup> /rad	25.00	RW	Uni		US
13.10	Position controller mode	0 to 6	0	RW	Uni		US
13.11	Absolute mode enable	OFF (0) or On(1)	OFF (0)	RW	Bit		US
13.12	Position controller speed clamp	0 to 250	150	RW	Uni		US
13.13	Orientation position reference	0 to 65535	0	RW	Uni		US
13.14	Orientation acceptance window	0 to 4096	256	RW	Uni		US
13.15	Orientation position complete	OFF (0) or On(1)		RO	Bit	NC	PT
13.16	Position error reset	OFF (0) or On(1)	OFF (0)	RW	Bit	NC	
13.17	Relative jog reference	0 to 4000.0 rpm	0.0	RW	Uni		US
13.18	Relative jog enable	OFF (0) or On(1)	OFF (0)	RW	Bit	NC	
13.19	Relative jog reverse	OFF (0) or On(1)	OFF (0)	RW	Bit	NC	
13.20	Local reference turns	0 to 65535	0	RW	Uni	NC	
13.21	Local reference position	0 to 65535	0	RW	Uni	NC	
13.22	Local reference fine position	0 to 65535	0	RW	Uni	NC	
13.23	Local reference disable	OFF (0) or On(1)	OFF (0)	RW	Bit	NC	
13.24	Ignore local reference turns	OFF (0) or On(1)	OFF (0)	RW	Bit		US

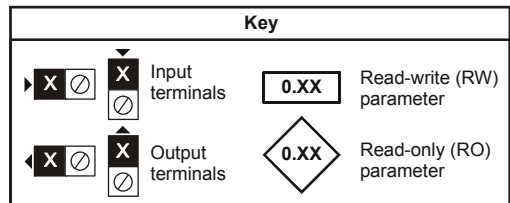
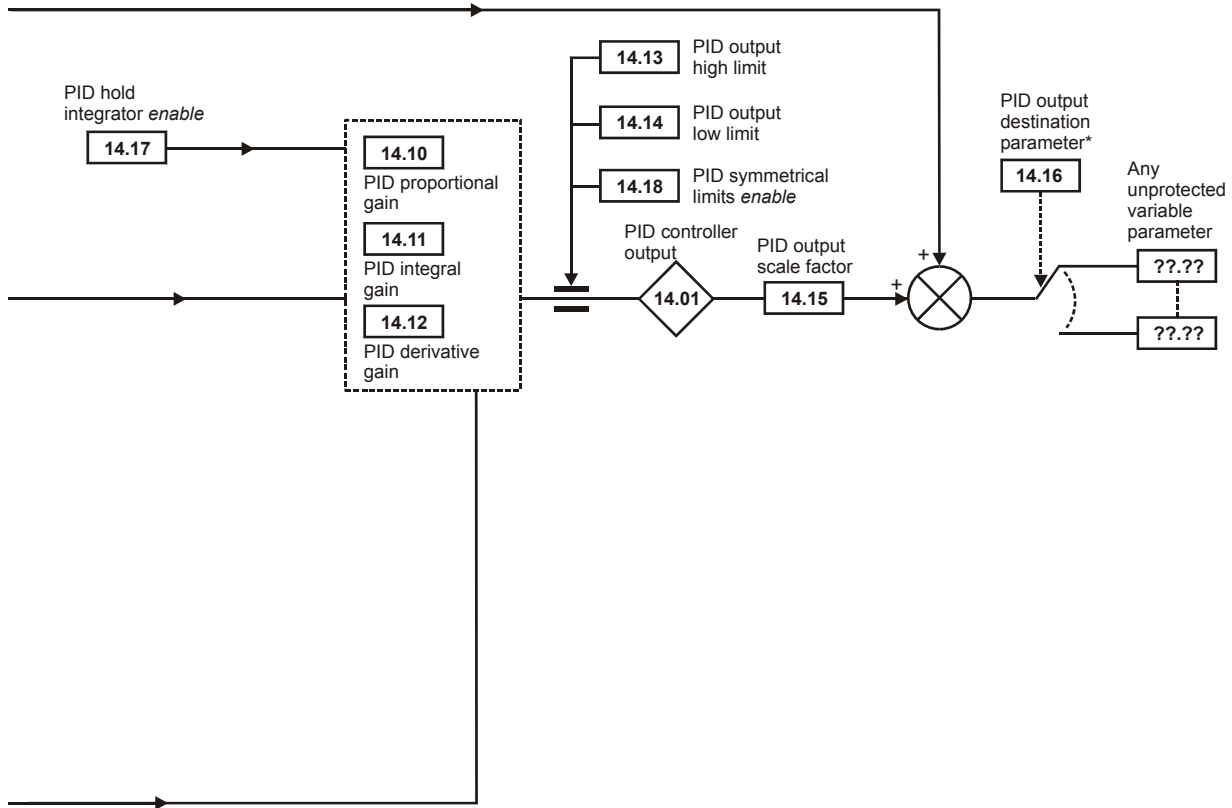
RW	Read / Write	RO	Read only	Uni	Unipolar	Bi	Bi-polar	Bit	Bit parameter	Txt	Text string		
FI	Filtered	DE	Destination	NC	Not copied	RA	Rating dependent	PT	Protected	US	User save	PS	Power down save



## 11.14 Menu 14: User PID controller

Figure 11-19 Menu 14 logic diagram





The parameters are all shown at their default settings

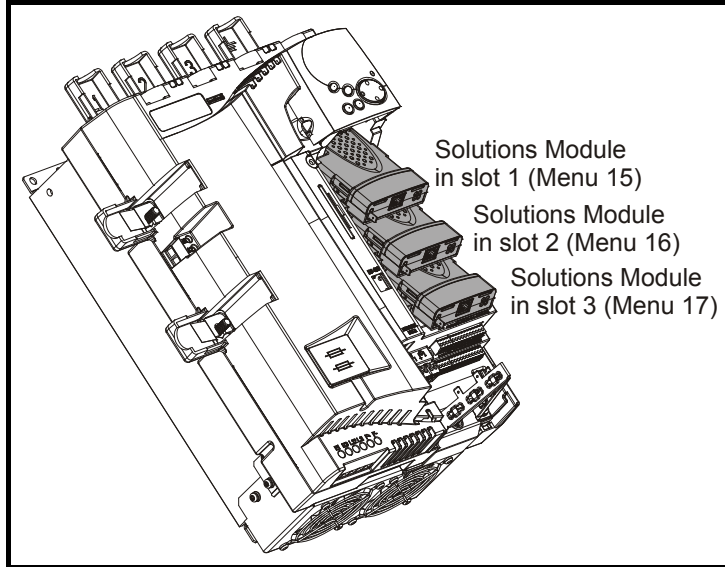
\*The PID controller is only enabled if Pr 14.16 is set to a non Pr xx.00 and unprotected destination parameter.

Parameter		Range(⇅)	Default(⇔)	Type					
14.01	PID output	±100.00 %		RO	Uni		NC	PT	
14.02	PID source1	Pr 0.00 to 22.99	Pr 0.00	RW	Uni			PT	US
14.03	PID source 2	Pr 0.00 to 22.99	Pr 0.00	RW	Uni			PT	US
14.04	PID source 3	Pr 0.00 to 22.99	Pr 0.00	RW	Uni			PT	US
14.05	PID source invert 1	OFF (0) or On (1)	OFF (0)	RW	Bit				US
14.06	PID source invert 2	OFF (0) or On (1)	OFF (0)	RW	Bit				US
14.07	PID reference slew rate limit	0 to 3200.0s	0.0	RW	Uni				US
14.08	PID enable	OFF (0) or On (1)	OFF (0)	RW	Bit				US
14.09	PID optional enable source	Pr 0.00 to 22.99	Pr 0.00	RW	Uni			PT	US
14.10	PID P gain	0 to 4.000	1.000	RW	Uni				US
14.11	PID I gain	0 to 4.000	0.500	RW	Uni				US
14.12	PID D gain	0 to 4.000	0.000	RW	Uni				US
14.13	PID upper limit	0 to 100.00 %	100.00	RW	Uni				US
14.14	PID lower limit	±100.00 %	-100.00	RW	Bi				US
14.15	PID scaling	0 to 4.000	1.000	RW	Uni				US
14.16	PID destination	Pr 0.00 to 22.99	Pr 0.00	RW	Uni			PT	US
14.17	PID hold integrator	OFF (0) or On (1)	OFF (0)	RW	Bit		NC		
14.18	PID symmetrical limit enable	OFF (0) or On (1)	OFF (0)	RW	Bit				US
14.19	PID main reference	±100.00 %		RO	Bi		NC	PT	
14.20	PID reference	±100.00 %		RO	Bi		NC	PT	
14.21	PID feedback	±100.00 %		RO	Bi		NC	PT	
14.22	PID error	±100.00 %		RO	Bi		NC	PT	

RW	Read / Write	RO	Read only	Uni	Unipolar	Bi	Bi-polar	Bit	Bit parameter	Txt	Text string		
FI	Filtered	DE	Destination	NC	Not copied	RA	Rating dependent	PT	Protected	US	User save	PS	Power down save

## 11.15 Menus 15, 16 and 17: Solutions Module slots

Figure 11-20 Location of Solution Module slots and their corresponding menu numbers



Pr x.00 and Pr x.01 are always present in menus 15, 16 and 17. Pr x.01 indicates which type of module is present (0 = no module installed). When a module is installed the drive provides the relevant menu (menu 15 for slot 1, 16 for slot 2 and 17 for slot 3) depending on the Solutions Module installed. The possible categories are shown below.

Solutions Module ID	Module	Category
0	No module installed	
102	SM-Universal Encoder Plus	Feedback
104	SM-Encoder Plus and SM-Encoder Output Plus	
201	SM-I/O Plus	Automation (I/O Expansion)
203	SM-I/O Timer	
204	SM-I/O PELV	
205	SM-I/O24V Protected	
206	SM-I/O120V	
207	SM-I/O Lite	
208	SM-I/O 32	
304	SM-Applications Plus	Automation (Applications)
305	SM-Applications Lite V2	
306	SM-Register	
403	SM-PROFIBUS DP-V1	Fieldbus
404	SM-INTERBUS	
407	SM-DeviceNet	
408	SM-CANopen	
410	SM-Ethernet	
421	SM-EtherCAT	

Refer to the specific Solutions Module User Guide for more information.

Most modules include a processor and parameters are updated by the processor in the Solutions Module. However, dumb modules do not contain a processor and all parameters are updated by the drive processor.

Dumb Solutions Module parameters are read/written by the drive background task or at the combined update time for time critical parameters. The combined update time depends on the number and type of dumb Solutions Modules installed to the drive. For each Solutions Module the update rate of these parameters is specified as 4 ms, 8 ms, etc. The combined update time is the total of the update times for all dumb Solutions Modules installed.

For example, if a module with 4 ms update time and a module with 8 ms are installed to the drive, then the combined update time for the time critical parameters of each module is 12 ms.

In the parameter tables the update time added by the type of module is given, for example 4 ms for the SM-Encoder Plus or 8 ms for the SM-I/O Plus.

When parameters are saved by the user in the drive EEPROM the option code of the currently installed module is saved in EEPROM. If the drive is subsequently powered-up with a different module installed, or no module installed where a module was previously installed, the drive gives a Slot.dF trip. The menu for the relevant slot appears for the new module category with the default parameter values for the new category. The new parameters values are not stored in EEPROM until the user performs a parameter save.

### Solutions Module software

Most Solutions Modules contain software. The software version of the module can be checked by looking at Pr **x.02** and Pr **x.51**.

The software version takes the form of xx.yy.zz, where Pr **x.02** displays xx.yy and Pr **x.51** displays zz. I.e. for software version 01.01.00, Pr **x.02** would display 1.01 and Pr **x.51** would display 0

The SM-Encoder Plus, SM-Encoder Output Plus and SM-I/O Plus modules do not contain any software, so Pr **x.02** and Pr **x.51** either show 0 or the parameters do not appear.

#### Parameters common to all categories

Parameter		Range(⇅)	Default(⇔)	Type						
<b>x.01</b>	Solutions Module ID	0 to 599		RO	Uni			PT	US	
<b>x.02</b>	Solutions Module software version	0.00 to 99.99		RO	Uni		NC	PT		
<b>x.50</b>	Solutions Module error status	0 to 255		RO	Uni		NC	PT		
<b>x.51</b>	Solutions Module software sub-version	0 to 99		RO	Uni		NC	PT		

### 11.16 Menu 18: Application menu 1

Parameter		Range(⇅)	Default(⇔)	Type						
<b>18.01</b>	Application menu 1 power-down saved integer	-32,768 to +32,767	0	RW	Bi		NC		PS	
<b>18.02 to 18.10</b>	Application menu 1 read-only integer	-32,768 to +32,767	0	RO	Bi		NC			
<b>18.11 to 18.30</b>	Application menu 1 read-write integer	-32,768 to +32,767	0	RW	Bi					US
<b>18.31 to 18.50</b>	Application menu 1 read-write bit	OFF (0) or On (1)	0	RW	Bit					US

### 11.17 Menu 19: Application menu 2

Parameter		Range(⇅)	Default(⇔)	Type						
<b>19.01</b>	Application menu 2 power-down saved integer	-32,768 to +32,767	0	RW	Bi		NC		PS	
<b>19.02 to 19.10</b>	Application menu 2 read-only integer	-32,768 to +32,767	0	RO	Bi		NC			
<b>19.11 to 19.30</b>	Application menu 2 read-write integer	-32,768 to +32,767	0	RW	Bi					US
<b>19.31 to 19.50</b>	Application menu 2 read-write bit	OFF (0) or On (1)	0	RW	Bit					US

### 11.18 Menu 20: Application menu 3

Parameter		Range(⇅)	Default(⇔)	Type						
<b>20.01 to 20.20</b>	Application menu 3 read-write integer	-32,768 to +32,767	0	RW	Bi		NC			
<b>20.21 to 20.40</b>	Application menu 3 read-write long integer	-2 <sup>31</sup> to 2 <sup>31</sup> -1	0	RW	Bi		NC			

All menu 20 parameters are transferred to the SMARTCARD when a 4yyy transfer is performed. See section 9.3.1 *Writing to the SMARTCARD* on page 89 for more information.

RW	Read / Write	RO	Read only	Uni	Unipolar	Bi	Bi-polar	Bit	Bit parameter	Txt	Text string		
FI	Filtered	DE	Destination	NC	Not copied	RA	Rating dependent	PT	Protected	US	User save	PS	Power down save



## 11.19 Menu 21: Second motor parameters

Parameter		Range(⇅)	Default(⇒)	Type					
21.01	Maximum reference clamp	SPEED_LIMIT_MAX rpm	1000.0	RW	Uni				US
21.02	Minimum reference clamp	±SPEED_LIMIT_MAX rpm*	0.0	RW	Bi			PT	US
21.03	Reference selector	0 to 6	0 (A1.A2)	RW	Txt				US
21.04	Acceleration rate	0 to MAX_RAMP_RATE_M2	5.000	RW	Uni				US
21.05	Deceleration rate	0 to MAX_RAMP_RATE_M2	5.000	RW	Uni				US
21.06	Base speed	0 to 10000.0 rpm	1000	RW	Uni				US
21.07	Rated current	0 to RATED_CURRENT_MAX A	RATED_CURRENT_MAX	RW	Uni				US
21.08	Back emf set point	0 to ARMATURE_VOLTAGE_MAX V DC	For 480V drive: 440 Eur, 500 USA For 575V drive: 630 Eur, 630 USA For 690V drive: 760 Eur, 760 USA	RW	Uni				US
21.09	Rated voltage	0 to ARMATURE_VOLTAGE_MAX V DC	For 480V drive: 440 Eur, 500 USA For 575V drive: 630 Eur, 630 USA For 690V drive: 760 Eur, 760 USA	RW	Uni				US
21.10	Armature resistance	0 to 6.0000 Ω	0.0000	RW	Uni				US
21.11	Motor constant	0 to 100.0 %	50 %	RW	Uni		RA		US
21.12	Discontinuous current controller Ki gain	0 to 4000	200	RW	Uni		RA		US
21.13	Continuous current controller Kp gain	0 to 4000	100	RW	Uni		RA		US
21.14	Continuous current controller Ki gain	0 to 4000	50	RW	Uni		RA		US
21.15	Motor 2 active	OFF (0) or On (1)		RO	Bit		NC	PT	
21.16	Thermal time constant	0 to 3000.0	89.0	RW	Uni				US
21.17	Speed controller Kp gain	0.00 to 6.5535(1 / (rad/s))	0.0300	RW	Uni				US
21.18	Speed controller Ki gain	0.00 to 655.35(s / (rad/s))	0.10	RW	Uni				US
21.19	Speed controller Kd gain	0.00000 to 0.65535(1/s / (rad/s))	0.00000	RW	Uni				US
21.21	Speed feedback selector	0 to 5	5	RW	Txt				US
21.23	Rated field voltage	0 to 500 Vdc	Eur: 360, USA: 300	RW	Uni				US
21.24	Rated field current	0 to FIELD_CURRENT_SET_MAX	Size 1: 2A Eur, 8A, USA: 8A Size 2A&B Eur: 3A, USA: 20A Size 2C&D Eur: 5A, USA: 20A	RW	Uni		RA	PT	US
21.25	Motor saturation breakpoint 1	0 to 100 % of rated flux	50	RW	Uni				US
21.26	Motor saturation breakpoint 2	0 to 100 % of rated flux	75	RW	Uni				US
21.27	Motoring current limit	0 to MOTOR2_CURRENT_LIMIT_MAX %	150.0**	RW	Uni		RA		US
21.28	Regen current limit	0 to MOTOR2_CURRENT_LIMIT_MAX %	150.0**	RW	Uni		RA		US
21.29	Symmetrical current limit	0 to MOTOR2_CURRENT_LIMIT_MAX %	150.0**	RW	Uni		RA		US
21.30	Field thermal time constant	0.0 to 3000.0	24.0	RW	Uni				US
21.31	Flux loop P gain	0 to 30.0	3.0	RW	Uni				US
21.32	Flux loop I gain	0 to 300.0	60.0	RW	Uni				US
21.33	field weakening P gain	0 to 300.0	0.4	RW	Uni				US
21.34	field weakening I gain	0 to 300.0	5.0	RW	Uni				US
21.35	Rated field compensation factor	0 to 100 %	100 %	RW	Uni			PT	US

\*The range shown for Pr 21.02 shows the range used for scaling purposes (i.e. for routing to an analog output etc.). Further range restrictions are applied depending on the settings of Pr 1.08 and Pr 1.10.

\*\*These are the maximum default values. If the variable maximum of this parameter (MOTOR2\_CURRENT\_LIMIT\_MAX) gives a lower value with the default value of Motor rated current (Pr 21.07) the default of this parameter is at the lower value.

## 11.20 Menu 22: Additional Menu 0 set-up

Parameter		Range(⇅)	Default(⇒)	Type					
22.01 to 22.20	Parameter 00.xy setup	Pr 0.00 to 22.99	Pr 0.00	RW	Uni			PT	US

## 11.21 Menu 23: Header selections

Parameter		Range(⇅)	Default(⇒)	Type					
23.01	Sub block headers	0 to 7 (USEr (0), SET UP (1), diAGnoS (2), triPS (3), SP LOOP (4), SintEr (5), Fb SP (6), inPut (7))		RO	Uni		NC	PT	
23.02	Binary sum of per defined sub block enables	0 to 127		RO	Uni		NC	PT	
23.03 to 23.09	Pre-defined sub block enable	OFF (0) or On (1)	On (1)	RW	Bit				US

## 12 Technical data

### 12.1 Drive technical data

#### 12.1.1 Power and current ratings

The power ratings for the 480 V, 575 V and 690 V configurations are shown in Table 12-1, Table 12-2 and Table 12-3.

The continuous current ratings given are for a maximum ambient temperature of 40 °C and an altitude of 1000 m. For operation at higher temperatures and altitudes derating is required.

The maximum continuous output current rating of the drive should be 'derated' for operation at altitudes above 1000 m. The derating is to be 1 % derating of rated output current per 100 m above 1000 m to a maximum derating of 20 % at 3000 m.

**Table 12-1 480 V current ratings**

Model	AC input current	DC output current		Typical motor power	
	Continuous	Continuous	150 % overload	@ 400 Vdc	@ 500 Vdc
	A	A	A	kW	hp
MP25A4(R)	22	25	37.5	9	15
MP45A4(R)	40	45	67.5	15	27
MP75A4(R)	67	75	112.5	27	45
MP105A4(R)	94	105	157.5	37.5	60
MP155A4(R)	139	155	232.5	56	90
MP210A4(R)	188	210	315	75	125
MP350A4(R)	295	350	525	125	200
MP420A4(R)	350	420	630	150	250
MP550A4(R)	450	550	825	200	300
MP700A4(R)	585	700	1050	250	400
MP825A4(R)	665	825	1237.5	300	500
MP900A4(R)	725	900	1350	340	550
MP1200A4(R)	1050	1200	1800	450	750
MP1850A4(R)	1570	1850	2775	700	1150

**Table 12-2 575 V current ratings**

Model	AC input current	DC output current		Typical motor power (With Vdc = 630 V)	
	Continuous	Continuous	150 % overload	kW	hp
	A	A	A		
MP25A5(R)	22	25	37.5	14	18
MP45A5(R)	40	45	67.5	25	33
MP75A5(R)	67	75	112.5	42	56
MP105A5(R)	94	105	157.5	58	78
MP155A5(R)	139	155	232.5	88	115
MP210A5(R)	188	210	315	120	160
MP350A5(R)	295	350	525	195	260
MP470A5(R)	395	470*	705	265	355
MP700A5(R)	585	700	1050	395	530
MP825A5(R)	665	825*	1237.5	465	620
MP1200A5(R)	1050	1200	1800	680	910
MP1850A5(R)	1570	1850	2775	1045	1400

\* For this rating at 575 V, 150 % overload time is 20 s at 40 °C and 30 s at 35 °C

**Table 12-3 690 V current ratings**

Model	AC input current	DC output Current		Typical motor power (With Vdc = 760 V)	
	Continuous	Continuous	150 % Overload	kW	hp
	A	A	A		
MP350A6(R)	295	350	525	240	320
MP470A6(R)	395	470*	705	320	425
MP700A6(R)	585	700	1050	480	640
MP825A6(R)	665	825*	1237.5	650	850
MP1200A6(R)	1050	1200	1800	850	1150
MP1850A6(R)	1570	1850	2775	1300	1750

\* For this rating at 690 V, 150 % overload time is 20 s at 40 °C and 30 s at 35 °C

#### Maximum continuous input current

The values of maximum continuous input current are given to aid the selection of cables and fuses. These values are stated for worst-case conditions.

#### NOTE

For current ratings above 1850 A then parallel connection of the drives is required. However, this function is not implemented on firmware versions V01.05.02 and earlier.

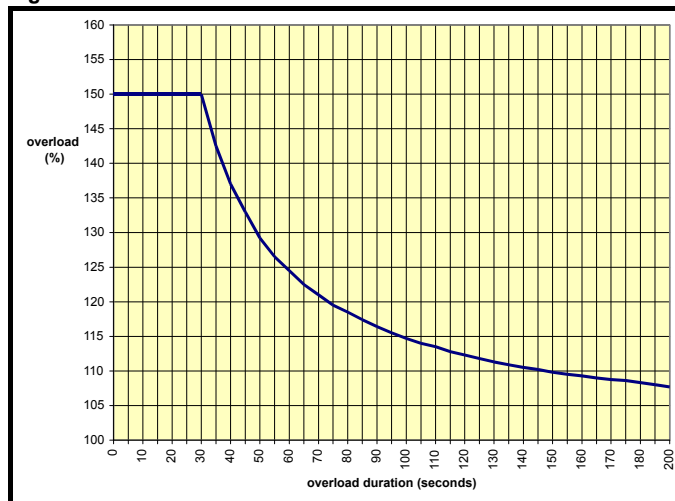
#### 12.1.2 Typical short-term overload limits

The maximum percentage overload limit changes depending on the selected motor

Variations in motor rated current will result in changes in the maximum possible overload as detailed in the *Mentor MP Advanced User Guide*.

Figure 12-1 can be used to determine the maximum overload duration available for overloads between 100 % and 150 %. For example the maximum overload available for a period of 60 seconds is 124 %.

**Figure 12-1 Maximum overload duration available**



#### NOTE

Overload of 150 % for 30 s is available up to a maximum of 10 repetitions per hour.

### 12.1.3 Drive derating for extended ambient operation

Figure 12-2 Mentor MP size 1A derating for extended ambient operation

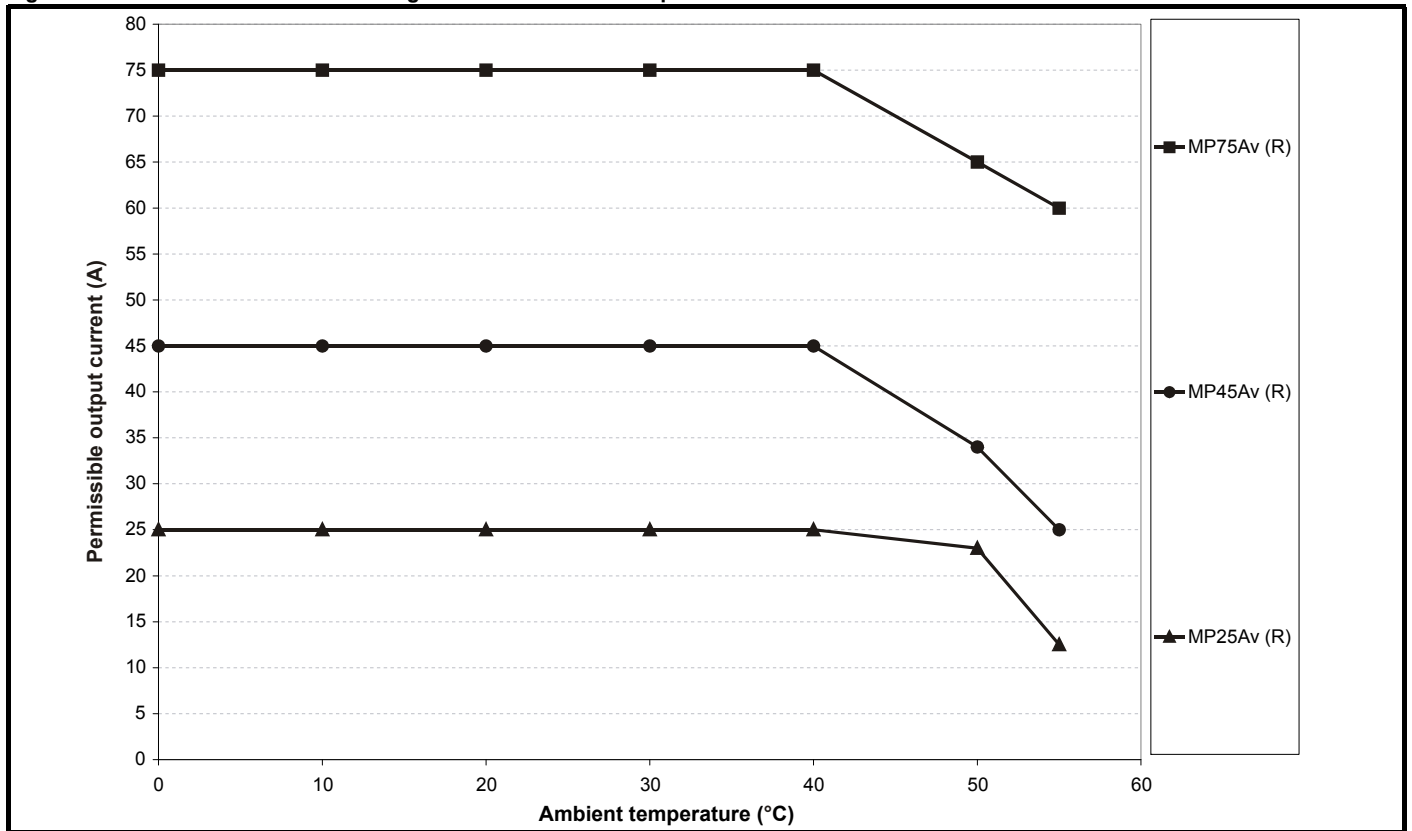


Figure 12-3 Mentor MP size 1B derating for extended ambient operation

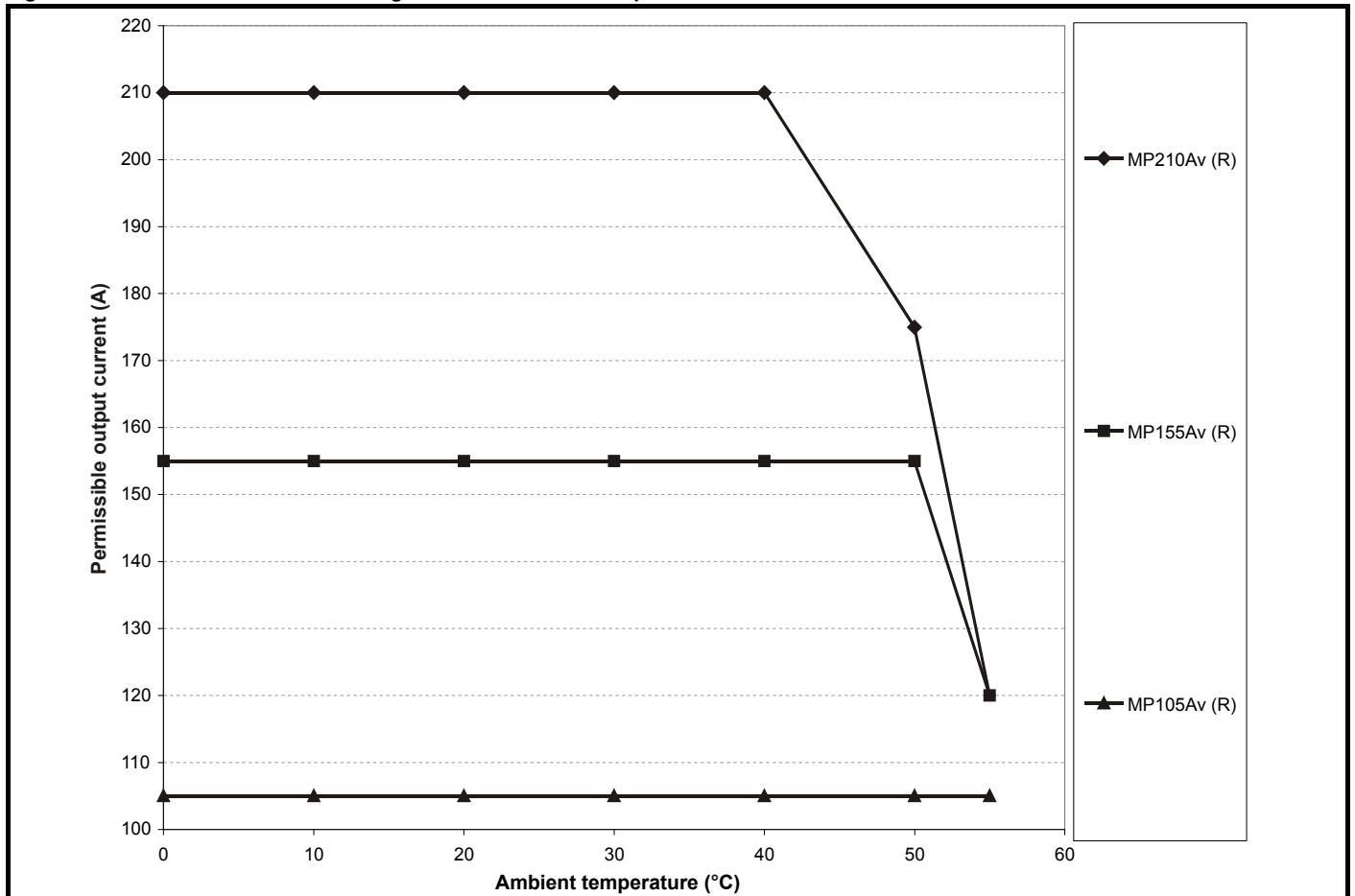


Figure 12-4 Mentor MP size 2A derating for extended ambient operation

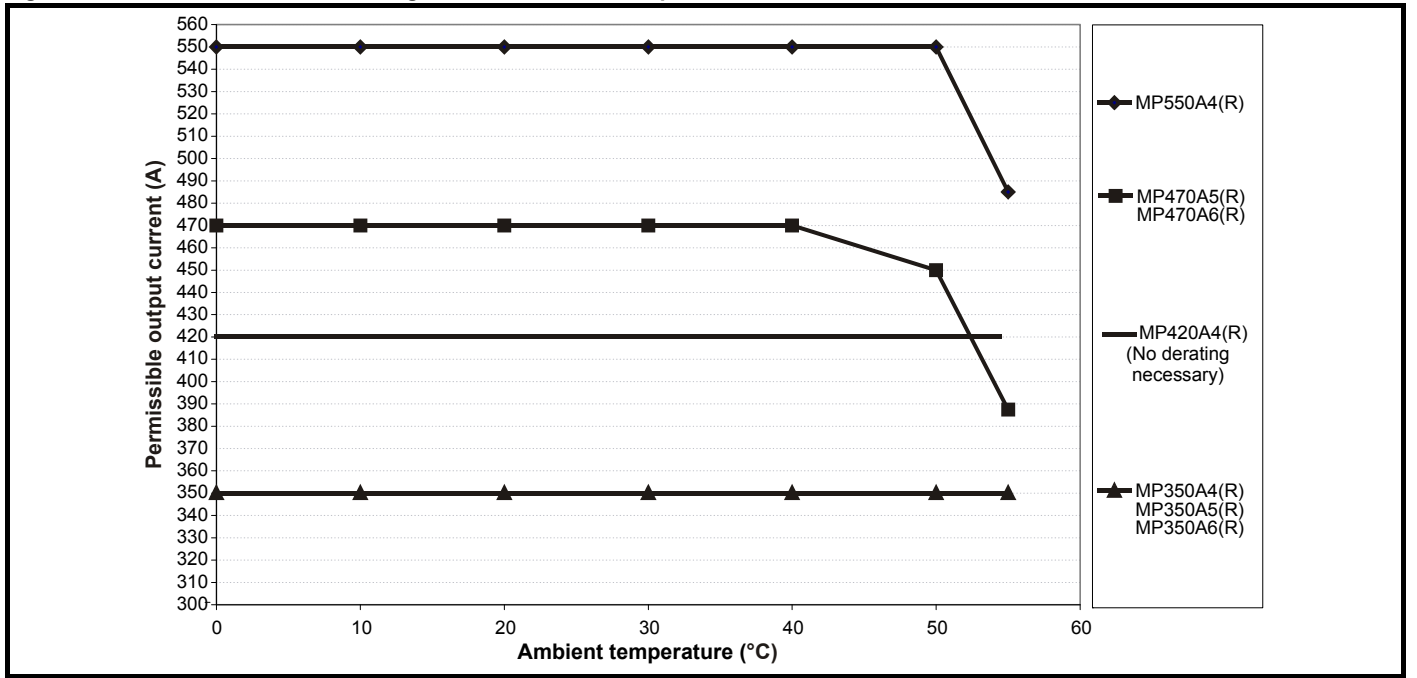
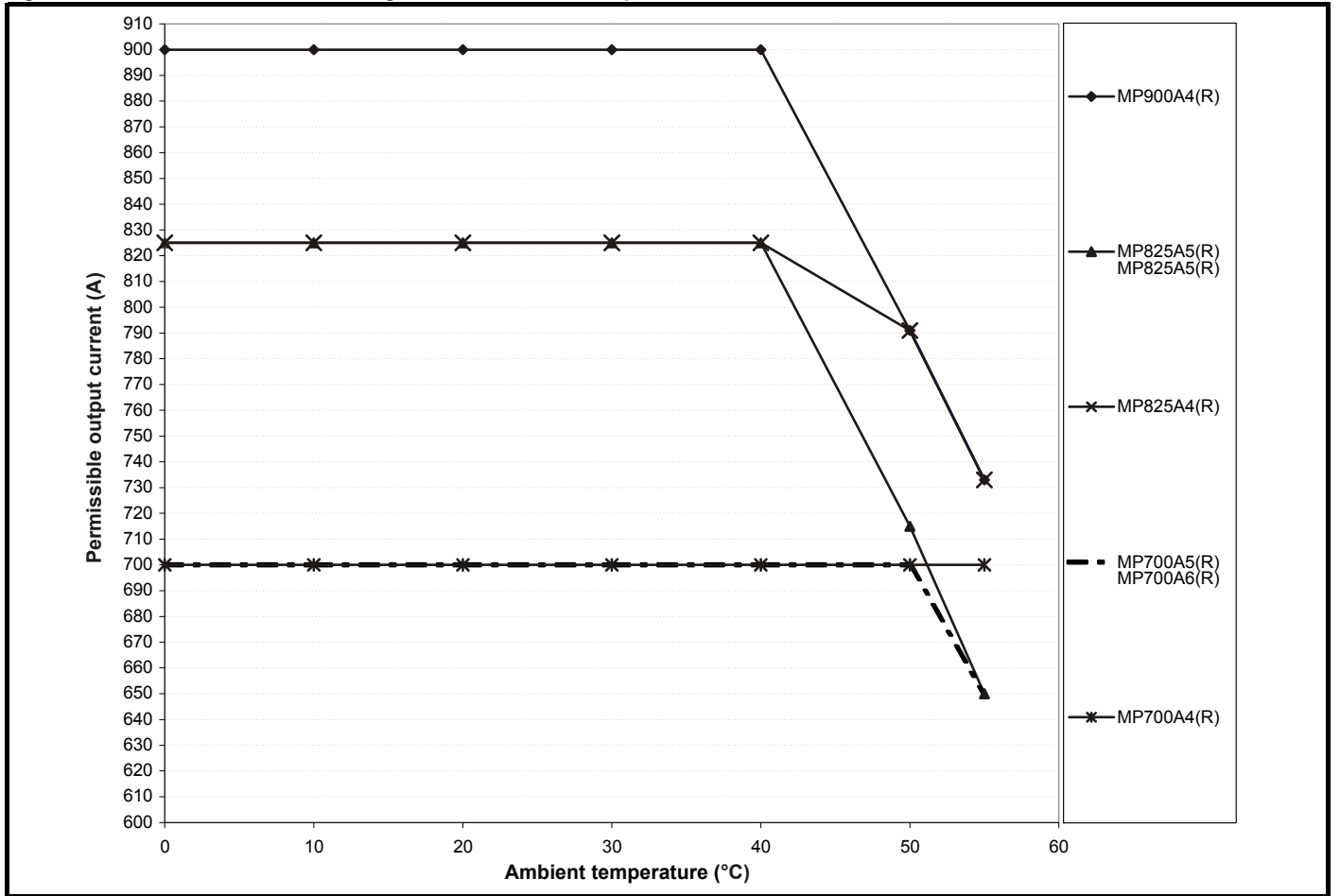
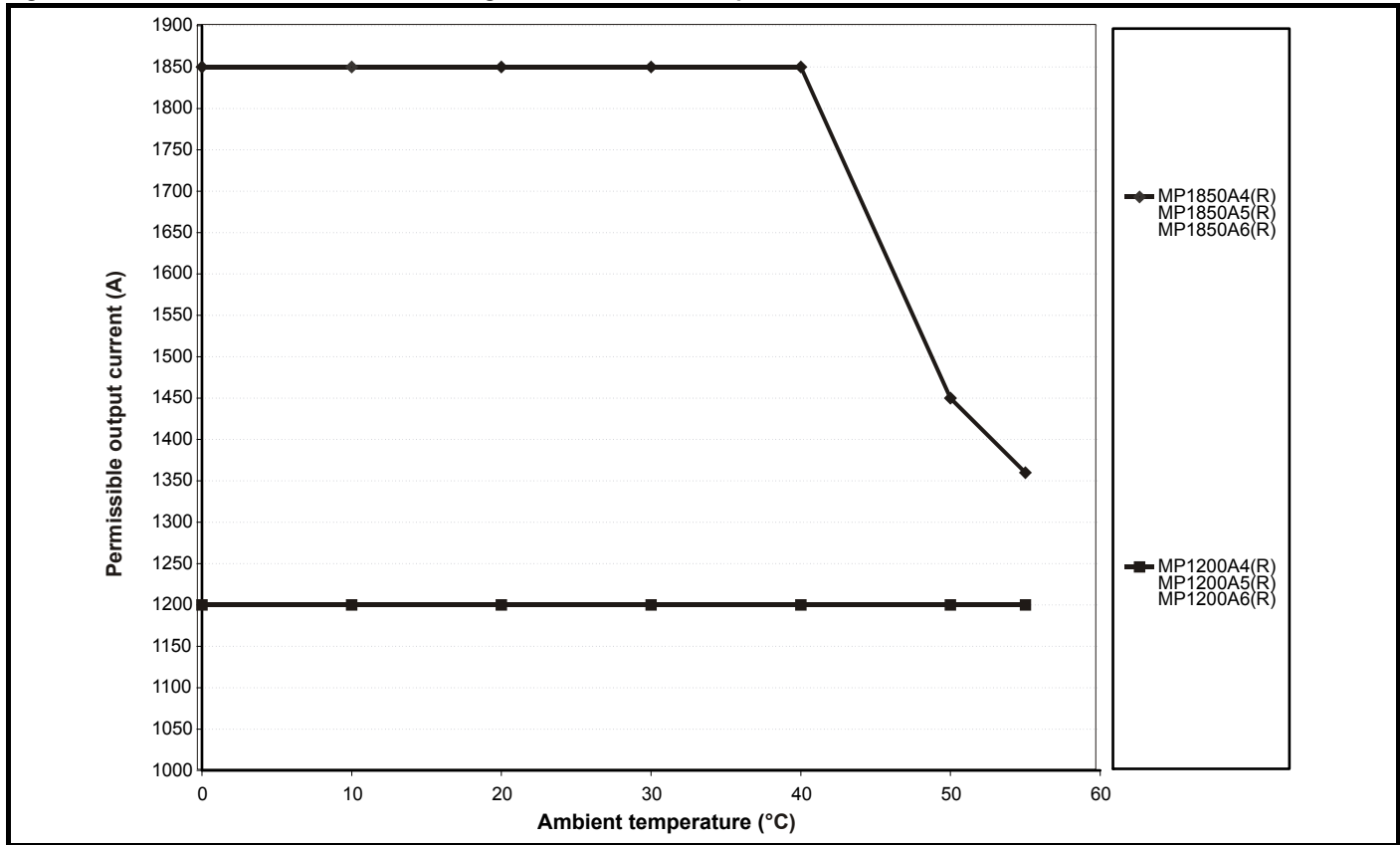


Figure 12-5 Mentor MP size 2B derating for extended ambient operation



**Figure 12-6 Mentor MP Size 2C and 2D derating for extended ambient operation**



**NOTE**

The derating graphs show the derating required for worst-case conditions.

## 12.1.4 Power dissipation

The table below shows the maximum drive losses, assuming high output current ripple content.

Table 12-4 Drive losses

Model	Loss @ 40 °C	Loss @ 50 °C	Loss @ 55 °C
	W	W	W
MP25A4(R) MP25A5(R)	125		91
MP45A4(R) MP45A5(R)	168	139	117
MP75A4(R) MP75A5(R)	219	194	183
MP105A4(R) MP105A5(R)	274		
MP155A4(R) MP155A5(R)	400		310
MP210A4(R) MP210A5(R)	561	456	
MP350A4(R)	954		
MP350A5(R) MP350A6(R)	1045		
MP420A4(R)	1154		
MP470A5(R) MP470A6(R)	1546	1268	1162
MP550A4(R)	1568		1354
MP700A4(R)	1663		
MP825A4(R)			
MP700A5(R) MP700A6(R)	1955		1795
MP825A4(R)	2160	1909	1751
MP825A5(R) MP825A6(R)	2381	2004	1795
MP900A4(R)	2220	1908	1751
MP1200A4(R)			
MP1200A5(R) MP1200A6(R)	3635	3660	
MP1850A4(R)			
MP1850A5(R) MP1850A6(R)	5203	4418	4139

Standby losses with the field disabled:

MP Size 1 = 33 W


MP Size 2 = 63 W

## 12.1.5 AC Supply requirements

The standard drive is rated for a nominal supply voltage up to 480 V rms.

An optional rating of 575 V rms is available for size 1 drives.

An optional rating of 575 V rms and 690 Vrms is available for size 2 drives.

	<p>Grounded delta supplies exceeding 575 V are not permitted for drives up to and including 210 A. Grounded delta supplies exceeding 600 V are not permitted for drives rated 350 A and above.</p>
--	--

## 12.1.6 Supply types

Drives rated for supply voltages of up to 575 V (rated up to 210 A) and 600 V (350 A and above), are suitable for use with any supply type i.e. TN-S, TN-C-S, TT, IT with grounding at any potential i.e. neutral, centre or corner ("Grounded delta").

Grounded delta supplies >575 V are not permitted for drives rated up to and including 210 A. Grounded delta supplies >600 V are not permitted for drives rated 350 A and above.

## 12.1.7 Main AC supply (L1, L2, L3)

Table 12-5 Three phase AC supply

Specification	Product voltage variant		
	480 V	575 V	690 V
Maximum nominal supply	480 V	575 V	690 V
Tolerance	+10 %		
Minimum nominal supply	24 V		
Tolerance	-20 %		

## 12.1.8 Auxiliary AC supply

Table 12-6 Line to line supply

Specification	Value
Maximum nominal supply	480 V
Tolerance	+10 %
Minimum nominal supply	208 V
Tolerance	-10 %

## 12.1.9 Line reactors

The Mentor MP, in common with all naturally commutated thyristor drives, causes voltage notches at the input supply terminals. In order to avoid disturbance to other equipment using the same supply, the addition of external line inductance is strongly recommended in order to restrict the depth of the notches imposed on the shared supply. This is generally not necessary where a dedicated transformer is used to supply the drive.

The following recommendations for added line inductance, have been calculated based on the power drive systems standard: EN 61800-3:2004 "Adjustable speed electrical power drive systems – Part 3: EMC requirements and specific test methods".

Table 12-7 Minimum required line inductance for a typical application (50 % ripple content)

Drive rated current A	System voltage				Typical current rating A	Maximum current rating A
	400 V µH	480 V µH	575 V µH	690 V µH		
25	220	260	320		21	22
45	220	260	320		38	40
75	220	260	320		63	67
105	220	260	320		88	94
155	160	190	230		130	139
210	120	140	170		176	188
350	71	85	110	120	293	295
420	59	71			351	350
470			80	91	393	395
550	45	54			460	450
700	36	43	53	61	586	585
825			45	52	690	665
900	28	33			753	725
1200	21	25	31	36	1004	1050
1850	18	23	29	32	1548	1450

### NOTE

1. The above assumes the supply has 1.5 % impedance.
2. Assumes a minimum supply rating of 5 kA and a maximum rating of 60 kA.

## 12.1.10 Temperature, humidity and cooling method

### Ambient temperature operating range:

0 °C to 55 °C (32 °F to 131 °F).

Output current derating must be applied at ambient temperatures >40 °C (104 °F).

### Minimum temperature at power-up:

The drive will power up at -15 °C (5 °F)

### Cooling method:

MP25Ax(R) and MP45Ax(R) = Natural convection.

MP75Ax(R) upwards = Forced cooling.

### Maximum humidity:

The Mentor MP Product range can operate in environments up to 90 % relative humidity at 50 °C.

## 12.1.11 Storage

-40 °C (-40 °F) to +55 °C (131 °F) for long term storage, or to +70 °C (158 °F) for short term storage.

Storage time is 2 years.

Electrolytic capacitors in any electronic product have a storage period after which they require reforming or replacing.

The DC bus capacitors have a storage period of 10 years.

The low voltage capacitors on the control supplies typically have a storage period of 2 years and are thus the limiting factor.

Low voltage capacitors cannot be reformed due to their location in the circuit and thus may require replacing if the drive is stored for a period of 2 years or greater without power being applied.

It is therefore recommended that drives are powered up for a minimum of 1 hour after every 2 years of storage.

This process allows the drive to be stored for a further 2 years.

## 12.1.12 Altitude

Altitude range: 0 to 3,000 m (9,900 ft), subject to the following conditions:

1,000 m to 3,000 m (3,300 ft to 9,900 ft) above sea level: derate the maximum output current from the specified figure by 1 % per 100 m (330 ft) above 1,000 m (3,300 ft)

For example at 3,000 m (9,900 ft) the output current of the drive would have to be derated by 20 %.

## 12.1.13 IP rating

The Mentor MP range of drives have the following Ingress Protection rating:

Table 12-8 IP rating

Frame size	IP Rating
1A	IP20 Protection against medium size foreign bodies $\varnothing > 12$ mm (finger) No protection against ingress of water
1B	
2A	IP10 Protection against large foreign bodies $\varnothing > 50$ mm (large area contact with hand) No protection against ingress of water
2B	
2C	IP00 No protection against contact, ingress of foreign bodies or ingress of water
2D	



### IP rating

It is the installer's responsibility to ensure that any enclosure which allows access to drives from frame sizes 2A to 2D while the product is energized, provides protection against contact and ingress to the requirements of IP20.

The IP rating of a product is a measure of protection against contact and ingress of foreign bodies and water. It is stated as IP XX, where the two digits (XX) indicate the degree of protection.

## 12.1.14 Corrosive gasses

Concentrations of corrosive gases must not exceed the levels given in:

- Table A2 of EN 50178:1998
- Class 3C2 of IEC 60721-3-3

This corresponds to the levels typical of urban areas with industrial activities and/or heavy traffic, but not in the immediate neighborhood of industrial sources with chemical emissions.

## 12.1.15 RoHS compliance

Mentor MP meets EU directive 2002/95/EC for RoHS compliance.

## 12.1.16 Vibration

Maximum recommended continuous vibration level 0.14 g r.m.s. broad-band 5 to 200 Hz.

### NOTE

This is the limit for broad-band (random) vibration. Narrow-band vibration at this level which coincides with a structural resonance could result in premature failure.

### Bump test

Testing in each of three mutually perpendicular axes in turn.

Referenced standard: IEC 60068-2-29: Test Eb:

Severity: 18 g, 6 ms, half sine

No. of Bumps: 600 (100 in each direction of each axis)

### Random vibration test

Testing in each of three mutually perpendicular axes in turn.

Referenced standard: IEC 60068-2-64: Test Fh:

Severity: 1.0 m<sup>2</sup>/s<sup>3</sup> (0.01 g<sup>2</sup>/Hz) ASD from 5 to 20 Hz

-3 dB/octave from 20 to 200 Hz

Duration: 30 minutes in each of 3 mutually perpendicular axes.

### Sinusoidal vibration test

Testing in each of three mutually perpendicular axes in turn.

Referenced standard: IEC 60068-2-6: Test Fc:

Frequency range: 5 to 500 Hz

Severity: 3.5 mm peak displacement from 5 to 9 Hz

10 m/s<sup>2</sup> peak acceleration from 9 to 200 Hz

15 m/s<sup>2</sup> peak acceleration from 200 to 500 Hz

Sweep rate: 1 octave/minute

Duration: 15 minutes in each of 3 mutually perpendicular axes.

EN 61800-5-1:2007, Section 5.2.6.4. referring to IEC 60068-2-6

Frequency range: 10-150 Hz

Amplitude: 10-57 Hz @ 0.075 mm pk

57-150 Hz @ 1g pk

Sweep rate: 1 octave/minute

Duration: 10 sweep cycles per axes in each of 3 mutually perpendicular axes

### Shock test

BS EN 60068-2-27, Test Ea

Pulse shape: half-sine

Severity: 15 g pk acceleration, 11 ms pulse duration

No of shocks: 3 in each direction of 3 mutually perpendicular axes (total of 18)

## 12.1.17 Start up time

This is the time taken from the moment of applying power to the drive, to the drive being ready to run a motor:

All sizes: 2 s

## 12.1.18 Output speed range

Speed range: 0 to 10,000 rpm

## 12.1.19 Accuracy

Accuracy in estimated speed mode: Typically 5 to 10 %.

Other modes are dependent on feedback device used.

### 12.1.20 Acoustic noise

The heatsink fan generates the majority of the acoustic noise produced by the drive. The heatsink fan on the Mentor MP is a single speed fan.

Table 12-9 gives the acoustic noise produced by the drive.

**Table 12-9 Acoustic noise data**

Model			Frame size	SPL at 1m (dBA)
MP25A4(R)	MP25A5(R)		1A	No fans installed
MP45A4(R)	MP45A5(R)			
MP75A4(R)	MP75A5(R)			
MP105A4(R)	MP105A5(R)		1B	56
MP155A4(R)	MP155A5(R)			
MP210A4(R)	MP210A5(R)			
MP350A4(R)	MP350A5(R)	MP350A6(R)	2A	68
MP420A4(R)	MP470A5(R)	MP470A6(R)		
MP550A4(R)				
MP700A4(R)	MP700A5(R)	MP700A6(R)	2B	67*
MP825A4(R)	MP825A5(R)	MP825A6(R)		
MP900A4(R)				
MP1200A4	MP1200A5	MP1200A6	2C	67*
MP1850A4	MP1850A5	MP1850A6		
MP1200A4R	MP1200A5R	MP1200A6R	2D	67*
MP1850A4R	MP1850A5R	MP1850A6R		

**NOTE**

\* The acoustic noise figure for frame sizes 2C and 2D has been taken with the bottom right angle ducting removed.

### 12.1.21 Cooling fan air flow

Mentor MP drives rated 75 A to 900 A are ventilated by internally supplied fans.

Ensure the minimum clearances around the drive are maintained to allow the air to flow freely. The air flow figures are listed below:

- Size 1A - 0.5 cubic metres per minute.
- Size 1B - 2.8 cubic metres per minute.
- Size 2A - 7.8 cubic metres per minute.
- Size 2B - 7.8 cubic metres per minute.

Mentor MP drives rated 1200 A and above are ventilated by externally supplied fans. Please refer to section 4.12 *Connecting the fan on size 2C and 2D drives* on page 55 for more information.

The air flow figures are listed below:

- Size 2C - 22 cubic metres per minute.
- Size 2D - 22 cubic metres per minute.

The drive controls the fan operation based on the temperature of the heatsink and the drives thermal model system.

### 12.1.22 Overall dimensions


Refer to section 3.4 *Mounting method* on page 19.

### 12.1.23 Weights

**Table 12-10 Overall drive weights**

Model			Frame size	kg	lb
MP25A4	MP25A5		1A	10	22
MP45A4	MP45A5			10.1	22.3
MP75A4	MP75A5			10.2	22.5
MP25A4R	MP25A5R		1B	10.5	23.1
MP45A4R	MP45A5R			12.6	27.8
MP75A4R	MP75A5R			13.0	28.7
MP105A4	MP105A5		2A	35	77.2
MP155A4	MP155A5				
MP210A4	MP210A5				
MP105A4R	MP105A5R		2A	38	83.8
MP155A4R	MP155A5R				
MP210A4R	MP210A5R				
MP350A4	MP350A5	MP350A6	2B	41	90.4
MP420A4					
	MP470A5	MP470A6			
MP550A4			2C	100	220.5
MP350A4R	MP350A5R	MP350A6R			
MP420A4R					
	MP470A5R	MP470A6R	2D	138	304.2
MP550A4R					
MP700A4	MP700A5	MP700A6			
MP825A4	MP825A5	MP825A6	2B	46	101.4
MP900A4					
MP700A4R	MP700A5R	MP700A6R			
MP825A4R	MP825A5R	MP825A6R	2C	100	220.5
MP900A4R					
MP1200A4	MP1200A5	MP1200A6			
MP1850A4	MP1850A5	MP1850A6	2D	138	304.2
MP1200A4R	MP1200A5R	MP1200A6R			
MP1850A4R	MP1850A5R	MP1850A6R			

## 12.2 Cable and fuse size ratings



The selection of the correct fuse is essential to ensure the safety of the installation

**WARNING**

Maximum continuous input currents are given in section 2.2 *Current ratings* on page 8 to aid the selection of fuses and cabling. The maximum input current is dependent on the ripple content of the output current. A value of 100 % ripple has been assumed for the given ratings.

The cable sizing selected when installing a Mentor MP must comply with the local wiring regulations. The information provided in this section is provided for guidance purposes only.

The power terminals on Mentor MP frame size 1 drives have been designed to accommodate a maximum cable size of 150 mm<sup>2</sup> (350 kcmil) with a temperature of 90 °C (194 °F).

The power terminals on Mentor MP frame size 2A drives have been designed to accommodate a maximum cable size of 2 x 150 mm<sup>2</sup> (2 x 350 kcmil) with a temperature of 75 °C (167 °F).

The power terminals on Mentor MP frame size 2B drives have been designed to accommodate 2 x 240 mm<sup>2</sup> with a temperature of 90 °C (194 °F). The use of cables sized using the US national electrical code as shown in Table 12-13 requires the use of a terminal adaptor.

The power terminals on Mentor MP frame size 2C and 2D drives have been designed for use with busbars. The drive can be used with cables as shown in Table 12-13 with the use of a terminal adaptor.



The actual cable size depends on a number of factors including:

- Actual maximum continuous current
- Ambient temperature
- Cable support, method and grouping
- Cable voltage drop

In applications where the motor used is of a reduced rating, the cable sizing selected can be appropriate for that motor. To protect the motor and the output cabling the drive must be programmed with the correct motor rated current.

**NOTE**

When using reduced cable sizes, the branch circuit protection fuse rating needs to be reduced in line with the cable size selected.

The following table shows typical cable sizes based on USA and International standards, assuming 3 conductors per raceway/conduit, an ambient temperature of 40 °C (104 °F) and applications with high output current ripple content.

**Table 12-11 Typical cable sizes for size 1 drives**

Model		IEC 60364-5-52 <sup>[1]</sup>		UL508C/NEC <sup>[2]</sup>	
		Input	Output	Input	Output
MP25A4(R)	MP25A5(R)	2.5 mm <sup>2</sup>	4 mm <sup>2</sup>	8 AWG	8 AWG
MP45A4(R)	MP45A5(R)	10 mm <sup>2</sup>	10 mm <sup>2</sup>	4 AWG	4 AWG
MP75A4(R)	MP75A5(R)	16 mm <sup>2</sup>	25 mm <sup>2</sup>	1 AWG	1/0 AWG
MP105A4(R)	MP105A5(R)	25 mm <sup>2</sup>	35 mm <sup>2</sup>	1/0 AWG	1/0 AWG
MP155A4(R)	MP155A5(R)	50 mm <sup>2</sup>	70 mm <sup>2</sup>	3/0 AWG	4/0 AWG
MP210A4(R)	MP210A5(R)	95 mm <sup>2</sup>	95 mm <sup>2</sup>	300 kcmil	350 kcmil

**NOTE**

1. The maximum cable size is defined by the power terminal housing using 90 °C (194 °F) rated cables as per Table A.52-5 of the standard.
2. Assumes the use of 75 °C rated cables, as per Table 310.16 of the National Electrical Code.

The use of higher temperature rated cable would allow a reduction on the minimum recommended cable size for Mentor MP shown above. For high temperature cable sizing, please refer to the data supplied by the manufacturer of the high temperature cable.

**Table 12-12 Auxiliary wiring for size 1 drives**

Frame size	Maximum input current	Continuous output current	IEC 60364-5-52 Table A52-4 Column B2		UL 508C	
			Column B2 derated by 0,87 of PVC at 40		E1, E3 size	F+, F-, L11 & L12 size
			E1, E3 size	F+, F-, L11 & L12 size		
			A	A	mm <sup>2</sup>	mm <sup>2</sup>
1	13	8	2.5	1.5	14 AWG	14 AWG

**Notes for IEC 60364:**

IEC 60364-5-52 use installation method B2, Table A.52-4 for three loaded conductors, PVC insulation 30 °C and apply derating factor for 40 °C from Table A.52-14 (0.87 for PVC).

**Notes for UL508C:**

Either 60 °C or 75 °C cable can be used. Ampacities as per table 40.3 as described in the UL508C standard.

**Table 12-13 Typical cable sizes for size 2 drives**

Model			Maximum input current	Continuous output current	IEC 60364-5-52 Table A52-12 Column 5 derated by 0.91 for 40 °C XLPE cables (IEC 60364-5-52 table A52-14) and 0.77 for cables bunching (IEC 60364-5-52 table A52-17 item 4)		US National Electrical Code	
					90 °C cables at 40 °C ambient		75 °C cable at 40 °C ambient	
			A	A	Input size mm <sup>2</sup>	Output size mm <sup>2</sup>	Input cables Kcmil	Output cables Kcmil
MP350A4(R)	MP350A5(R)	MP350A6(R)	295	350	120	150	350	400
MP420A4(R)			350	420	150	185	400	500
	MP470A5(R)	MP470A6(R)	395	470	185	240	500	600
MP550A4(R)			450	550	300	2 x 150	2 x 300	2 x 350
MP700A4(R)	MP700A5(R)	MP700A6(R)	585	700	2 x 150	2 x 185	2 x 500	2 x 600
MP825A4(R)	MP825A5(R)	MP825A6(R)	665	825	2 x 185	2 x 240	2 x 600	3 x 350
MP900A4(R)			725	900	2 x 185	2 x 240	3 x 350	3 x 400
MP1200A4(R)	MP1200A5(R)	MP1200A6(R)	1050	1200	2 x 300	3 x 240	3 x 600	4 x 400
MP1850A4(R)	MP1850A5(R)	MP1850A6(R)	1655	1850	4 x 240	4 x 300	*	*

\* Values are beyond the mechanical design of the drive. At this power level it may be prudent to consider bus-bars.

**Notes for IEC 60364:**

**NOTE**

1. IEC 60364-5-52 Table A 52-12 F method column 5 = Single core cable in free air.
2. IEC 60364-5-52 table A52-14 correction factor for ambient air temperature others than 30 °C.
3. IEC 60364-5-52 table A52-17 item 4 correction factor for groups of more than one circuit or more than one multi-core cable placed on a single layer on a perforated tray.

**NOTE**

**Notes for US National Electrical Code:**

1. Table 310.17 allowable ampacities of single-insulated conducted rated 0 through 2,000 V in free air, based on ambient air temperature of 30 °C (87 °F).
2. Derating factor of 0.88 is applied for 40 °C to the 75 °C cable column. Table 310.17 is based on 30 °C (86 °F) ambient air temperature.
3. NEC 2005 edition Table 310.15(B)(2)(a) shows the adjustment factors for more than three current-carrying conductors in a race way or cable, for 4-6 current-carrying conductors 0.80 derating factor is applied.

**Table 12-14 Auxiliary wiring for size 2 drives**

Frame size	Maximum input current	Continuous output current	IEC 60364-5-52 Table A52-4 Column B2		UL 508C	
			Column B2 derated by 0,87 of PVC at 40		E1, E3 size	F+, F-, L11 & L12 size
			E1, E3 size	F+, F-, L11 & L12 size		
	A	A	mm <sup>2</sup>	mm <sup>2</sup>	mm <sup>2</sup>	mm <sup>2</sup>
2	23	20	6	4	10 AWG	10 AWG

**Notes for IEC 60364:**

IEC 60364-5-52 use installation method B2, Table A.52-4 for three loaded conductors, PVC insulation 30 °C and apply derating factor for 40 °C from Table A.52-14 (0.87 for PVC).

**Notes for UL508C:** Either 60 °C or 75 °C cable can be used. Ampacities as per table 40.3 as described in the UL508C standard.

## 12.2.1 Ferraz Shawmut fuses



### Fuses

The AC supply to the drive must be installed with suitable protection against overload and short-circuits. The following tables show the recommended fuses. Failure to observe this requirement will cause risk of fire.

**WARNING**

Ferraz Shawmut fuses are recommended for the Mentor MP.

**Table 12-15 Ferraz Shawmut semiconductor fusing for size 1 drives**

Model	International				USA				
	Description	Catalog No.	Ref No.	UL app	Description	Catalog No.	Ref No.	UL app	
Field fuses	10 x 38 mm Ferrule	FR10GB69V12.5	H330011	√	10 x 38 mm Ferrule	FR10GB69V12.5	H330011	√	
MP25A4	22 x 58 mm Ferrule	FR22GC69V32	A220915	√	A50QS Series round fuse	A50QS40-4	Y215583	√	
MP25A5									
MP45A4		FR22GC69V63	X220912	√	A50QS Series round fuse	A50QS70-4	B222664	√	
MP45A5									
MP75A4		FR22GC69V100	W220911	√	A50QS Series round fuse	A50QS125-4	K218417	√	
MP75A5									
MP25A4R		FR22GC69V32	A220915	√	A70QS Series round fuse	A70QS60-4	H219473		
MP25A5R									
MP45A4R		FR22GC69V63	X220912	√	A70QS Series round fuse	A70QS80-4	X212816		
MP45A5R									
MP75A4R		FR22GC69V100	W220911	√	A70QS Series round fuse	A70QS125-4	Q216375		
MP75A5R									
MP105A4		Size 30 Square body fuse	PC30UD69V160EF	M300092	√	A50QS Series round fuse	A50QS175-4	A222663	√
MP105A5									
MP155A4	PC30UD69V200EF		N300093	√	A50QS Series round fuse	A50QS250-4	W211251	√	
MP155A5									
MP210A4	PC30UD69V315EF		Q300095	√	A50QS Series round fuse	A50QS350-4	T215343	√	
MP210A5									
MP105A4R	Size 70 Square body fuse	PC70UD13C160EF	T300604	√	A70QS Series round fuse	A70QS175-4	A223192		
MP105A5R									
MP155A4R		PC70UD13C200EF	V300605	√	A70QS Series round fuse	A70QS250-4	L217406		
MP155A5R									
MP210A4R		PC70UD12C280EF	L300712	√	A70QS Series round fuse	A70QS350-4	M211266		
MP210A5R									

**NOTE**

A50QS series are only rated up to 500 Vac.

**Table 12-16 Ferraz Shawmut branch circuit protection fusing for size 1 drives**

Model	International				USA		
	Description	Catalog No.	Ref No.	UL app	Catalog No.	UL app	
Auxiliary	21 x 57 mm Cylindrical	HSJ15	D235868		AJT10	√	
MP25A4	MP25A5	22 x 58 mm Ferrule	FR22GG69V25	N212072		AJT30	√
MP45A4	MP45A5		FR22GG69V50	P214626		AJT45	√
MP75A4	MP75A5		FR22GG69V80	Q217180		AJT70	√
MP25A4R	MP25A5R		FR22GG69V25	N212072		AJT30	√
MP45A4R	MP45A5R		FR22GG69V50	P214626		AJT45	√
MP75A4R	MP75A5R		FR22GG69V80	Q217180		AJT70	√
MP105A4	MP105A5		NH 00 Knife Blade	NH00GG69V100	B228460		AJT125
MP155A4	MP155A5	NH 1 Knife Blade	NH1GG69V160	F228487		AJT175	√
MP210A4	MP210A5		NH1GG69V200	G228488		AJT225	√
MP105A4R	MP105A5R	NH 00 Knife Blade	NH00GG69V100	B228460		AJT125	√
MP155A4R	MP155A5R	NH 1 Knife Blade	NH1GG69V160	F228487		AJT175	√
MP210A4R	MP210A5R		NH1GG69V200	G228488		AJT225	√

**Table 12-17 Ferraz Shawmut DC Semiconductor protection fusing for size 1 drives**

Model	International				USA			
	Description	Catalog No.	Ref No.	UL app	Description	Catalog No.	Ref No.	UL app
MP25A4R	20 x 127 mm Cylindrical	FD20GB100V32T	F089498		A70QS Series round fuse	A70QS60-4	H219473	√
MP25A5R								
MP45A4R	36 x 127 mm Cylindrical	FD36GC100V80T	A083651		A70QS Series round fuse	A70QS80-4	X212816	√
MP45A5R								
MP75A4R	20 x 127 mm Cylindrical	FD20GC100V63T x 2 connected in parallel	F083656		A70QS Series round fuse	A70QS125-4	Q216375	√
MP75A5R								
MP105A4R	Size 120 Square body	D120GC75V160TF	R085253		A70QS Series round fuse	A70QS175-4	A223192	√
MP105A5R								
MP155A4R	Size 121 Square body	D121GC75V250TF	Q085252		A70QS Series round fuse	A70QS250-4	L217406	√
MP155A5R								
MP210A4R	Size 122 Square body	D122GC75V315TF	M085249		A70QS Series round fuse	A70QS350-4	M211266	√
MP210A5R								

**NOTE**

The above DC fuse recommendations are not required for UL conformity of the Mentor MP drive. Any installations required to meet NEC and/or UL508a panel requirements, must use recognized fuses that meet the requirements of the standard being applied. The UL columns above indicate whether the recommended fuse is a UL recognized component and not its conformance to either NEC or UL508a.

DC fusing is required on four quadrant (R) drives only.

**Table 12-18 Ferraz Shawmut semiconductor fusing for size 2 drives**

Model	International				USA			
	Description	Catalog No.	Ref No.	UL app	Description	Catalog No.	Ref No.	UL app
Field fuses (all size 2)	10 x 38 mm Ferrule	FR10GR69V25	F1014581	√	10 x 38 mm Ferrule	FR10GR69V25	F1014581	√
		FR10GB69V25	L330014			FR10GB69V25	L330014	
MP350A4	Square body fuses	PC30UD69V500TF	W300399	√	American round fuses	A50QS450-4	E216871	√
MP350A4R		PC71UD11V500TF	F300523	√		A70QS450-4	F214848	√
MP350A5		PC31UD69V500TF	T300006	√		A70QS450-4	F214848	√
MP350A6		PC31UD69V500TF	T300006			A70QS450-4	F214848	
MP350A5R		PC72UD13C500TF	D300498	√		A70QS450-4	F214848	√
MP350A6R		PC72UD13C500TF	D300498			A70QS450-4	F214848	
MP420A4		PC32UD69V630TF	M300069	√		A50QS600-4	Q219457	√
MP420A4R		PC272UD13C630TF	W300721	√		A70QS600-4	Y219993	√
MP470A5		PC272UD13C700TF	X300722	√		A70QS600-4	Y219993	√
MP470A6		PC272UD13C700TF	X300722			2 x A70QS400 in parallel	J214345 (x2)	
MP470A5R		PC272UD13C700TF	X300722	√				
MP470A6R		PC272UD13C700TF	X300722					
MP550A4		PC33UD69V700TF	Y300079	√		A50QS700-4	N223181	√
MP550A4R		PC272UD13C700TF	X300722	√		A70QS700-4	E202772	√
MP700A4		PC32UD69V1000TF	S300074	√		A70QS700-4	E202772	√
MP700A4R		PC72UD10C900TF	G300869	√		A50QS900-4	R212282	√
MP700A5		PC32UD69V1000TF	S300074	√		2 x A70QS500-4 in parallel	A218431 (x2)	
MP700A6		PC32UD69V1000TF	S300074					
MP700A5R		PC73UD12C900TF	T300512	√		2 x A70QS500 in parallel	A218431 (x2)	
MP700A6R		PC73UD12C900TF	T300512					
MP825A4	PC32UD69V1100TF	M300759	√	A50QS1200-4	C217904	√		
MP825A5	PC33UD69V1100TF	C300083	√	2 x A70QS600-4 in parallel	Y219993 (x2)			
MP825A6	PC33UD69V1100TF	C300083						
MP825A4R	PC73UD95V800TFB	W300514	√	2 x A70QS600-4 in parallel	Y219993 (x2)			
MP825A5R	PC73UD95V800TFB	W300514						
MP825A6R	PC73UD95V800TFB	W300514						
MP900A4	PC33UD69V1250TF	D300084	√	A50QS1200-4	C217904	√		
MP900A4R	PC73UD95V800TFB	W300514	√	2 x A70QS600-4 in parallel	Y219993 (x2)			
MP1200A4	PC33UD60V1600TF	Z300586		2 x A70QS600-4 in parallel	Y219993 (x2)			
	A075URD44PPASF2400	K235184	√	2 x A50QS800-4 in parallel	C202287 (x2)			
				2 x A70QS800-4 in parallel	Z213830 (x2)			

Model	International				USA			
	Description	Catalog No.	Ref No.	UL app	Description	Catalog No.	Ref No.	UL app
MP1200A4R	Square body fuses	PC273UD11C16CTF	J302228		American round fuses	2 x A70QS800-4 in parallel	Z213830 (x2)	
		A075URD44PPASF2400	K235184	√				
MP1200A5		PC232UD69V16CTD	W300215					
		A075URD44PPASF2400	K235184	√				
MP1200A6		PC232UD69V16CTD	W300215					
		PC273UD11C16CTF	J302228					
MP1200A5R		A075URD44PPASF2400	K235184	√				
MP1200A6R		PC273UD11C16CTF	J302228					
MP1850A4		A075URD44PPASF2400**	K235184	√		2 x A50QS1000-4 in parallel.	B217391 (x2)	
MP1850A4R						3 x A70QS700-4 in parallel.	*E202772 (x3)	
MP1850A5						*3 x A70QS700-4 in parallel	*E202772 (x3)	
MP1850A6								
MP1850A5R								
MP1850A6R								

**NOTE**

A50QS series are only rated up to 500 Vac.

\*Application overload limited to infrequent overloads to avoid fuse wear out

\*\*Fuse limits applications to those operating at rated current. No cyclic overloads permitted.

**Table 12-19 Ferraz Shawmut branch circuit protection fusing for size 2 drives**

Model	International				USA						
	Description	Catalog No.	Ref No.	UL app	Description	Catalog No.	Ref No.	UL app			
Auxiliary	25 A 600 Vac High Speed Class J	HSJ205	G235871J	√	25 A 600 Vac High Speed Class J	AJT25R	X21160J	√			
MP350A4(R)	General purpose IEC (square body)	NH2GG69V355	Y228503		General purpose US (round body)	A6D400R	B216776	√			
MP350A5(R)											
MP350A6(R)											
MP420A4(R)						NH3GG69V400	D228508		A6D500R	P217294	√
MP470A5(R)						NH4GG69V630-8	E215537		A6D600R	T217804	√
MP470A6(R)						NH4AGG69V630-8	W222107				
MP550A4 (R)						NH4GG69V630-8	E215537				
MP700A4(R)						NH4AGG69V630-8	W222107		A4BQ800	Z219373	√
MP700A5(R)						NH4GG69V800-8	K216554				
MP700A6(R)						NH4AGG69V800-8	M222858				
MP825A4(R)						NH4GG69V800-8	K216554				
MP825A5(R)						NH4AGG69V800-8	M222858		A4BQ1000	P216282	√
MP825A6(R)	MF76GG69V1250	E302753			A4BQ1200	R216790	√				
MP900A4(R)					MF114GG69V2000	G302755		A4BQ2000	B223101	√	
MP1200A4(R)											MP1200A5(R)
MP1200A6(R)											
MP1850A4(R)	MP1850A5(R)										
	MP1850A6(R)										

**NOTE**

USA fuses are only rated up to 600 Vac.

**Table 12-20 Ferraz Shawmut DC protection fusing for size 2 drives**

Model	International				USA							
	Description	Catalog No.	Ref No.	UL recog	Description	Catalog No.	Ref No.	UL recog				
MP350A4R	Square Body fuse	D123GB75V630TF	C098557		American round fuse	A70QS600-4	Y219993	√				
MP350A5R						A100P600-4	A217373	√				
MP350A6R						A70QS800-4	Z213830	√				
MP420A4R		D123GB75V800TF	J220946		American round fuses 2 in parallel	A100P1000-4 (x2)	Y217371 (x2)					
MP470A5R		D2122GD75V900TF	T220955			A70QS450-4 (x2)	F214848 (x2)	√				
MP470A6R						A70QS600-4 (x2)	Y219993 (x2)	√				
MP550A4R					D2123GB75V12CTF	D098558		American round fuse	A100P1200-4	N218397		
MP700A4R		American round fuses 2 in parallel	A70QS800-4 (x2)	Z213830 (x2)								
MP700A5R			American round fuse	A100P1200-4				N218397				
MP700A6R		D2123GB75V14CTF	B090483		American round fuses 3 in parallel	A70QS600-4 (x3)	Y219993 (x3)					
MP825A4R						Square body fuses 3 in parallel	PC73UD13C630TF (x3)	Q300509 (x3)	American round fuses 3 in parallel	A70QS700-4 (x3)	E202772 (x3)	
MP825A5R										A100P700-4 (x3)	T223163 (x3)	
MP825A6R		Square body fuses 4 in parallel	PC73UD13C700TF (x4)	R300510 (x4)		American round fuses 5 in parallel	A70QS600-4 (x5)	Y219993 (x5)				
MP900A4R							A100P600-4 (x5)	A217373 (x5)				
MP1200A4R												
MP1200A5R												
MP1200A6R												
MP1850A4R												
MP1850A5R												
MP1850A6R												

**NOTE**

The above DC fuse recommendations are not required for UL conformity of the Mentor MP drive. Any installations required to meet NEC and/or UL508a panel requirements, must use recognized fuses that meet the requirements of the standard being applied. The UL columns above indicate whether the recommended fuse is a UL recognized component and not its conformance to either NEC or UL508a.

The use of the A100P series fuses is limited to applications with L/R time constants of 30 ms or less. DC fusing is only required on four quadrant (R) drives.

## 12.2.2 Alternative fusing

Cooper Bussmann or Siba fuses are an acceptable alternative.

### Cooper Bussmann

**Table 12-21 Cooper Bussmann semiconductor fusing for size 1 two quadrant drives**

Model		Fuse type	Rating V	Rating A	Catalog number	UL approved
Auxiliary		10.3 x 38 mm ferrule	600 Vac	12	FWC-12A10F	
MP25A4	MP25A5	ET Type BS88 fuse	690 Vac	40	40ET	√
MP45A4	MP45A5	FE Type BS88 fuse		80	80FE	√
MP75A4	MP75A5	EET Type BS88 fuse		140	140EET	√
MP105A4	MP105A5	FEE Type BS88 fuse		160	160FEE	√
MP155A4	MP155A5	FM Type BS88 fuse		250	250FM	√
MP210A4	MP210A5	FMM Type BS88 fuse		400	400FMM	√

**Figure 12-7 Cooper Bussmann North American alternative semiconductor fusing for size 1 two quadrant 480 V drives only**

Model		Fuse type	Rating V	Rating A	Catalog number	UL approved
MP25A4		FWH series American round fuse	500 Vac	40	FWH-40	
MP45A4				70	FWH-70	
MP75A4				125	FWH-125	
MP105A4				175	FWH-175	
MP155A4				250	FWH-250	
MP210A4				350	FWH-350	

**Table 12-22 Cooper Bussmann North American alternative semiconductor fusing for size 1 two quadrant 480 V and 575 V drives**

Model		Fuse type	Rating V	Rating A	Catalog number	UL approved
MP25A4	MP25A5	FWP series American round fuse	700 Vac	40	FWP-40	
MP45A4	MP45A5			70	FWP-70	
MP75A4	MP75A5			125	FWP-125	
MP105A4	MP105A5			175	FWP-175	
MP155A4	MP155A5			250	FWP-250	
MP210A4	MP210A5			300	FWP-300	

**Table 12-23 Cooper Bussmann North American alternative semiconductor fusing for size 1 two and four quadrant drives**

Model		Fuse type	Rating V	Rating A	Catalog number	UL approved
MP25A4(R)	MP25A5(R)	FWJ series American round fuse	1000 Vac	40	FWJ-40	
MP45A4(R)	MP45A5(R)			70	FWJ-70	
MP75A4(R)	MP75A5(R)			125	FWJ-125	
MP105A4(R)	MP105A5(R)			175	FWJ-175	
MP155A4(R)	MP155A5(R)			250	FWJ-250	
MP210A4(R)	MP210A5(R)			350	FWJ-350	

**Table 12-24 Cooper Bussmann branch circuit protection fusing for 480 V and 575 V size 1 drives**

Model		Fuse type	Rating V	Rating A	Catalog number	UL approved
Auxiliary		10.3 x 38 mm ferrule	600 Vac	12	LP-CC-12	
MP25A4(R)	MP25A5(R)	26.9 x 60.5 mm ferrule		30	LPJ-30SP	√
MP45A4(R)	MP45A5(R)			60	LPJ-60SP	√
MP75A4(R)	MP75A5(R)	Cylindrical bolt-in type fuse		80	LPJ-80SP	√
MP105A4(R)	MP105A5(R)			110	LPJ-110SP	√
MP155A4(R)	MP155A5(R)			175	LPJ-175SP	√
MP210A4(R)	MP210A5(R)			225	LPJ-225SP	√



**Table 12-25 Cooper Bussmann DC protection fusing for 480 V and 575 V size 1 drives**

Model	Fuse type	Rating V	Rating A	Catalog number	UL Recognized
MP25A4R	FWJ series American round fuse	1000 Vac	40	FWJ-40A	√
MP25A5R	AC fuse provides protection				
MP45A4R	FWJ series American round fuse	1000 Vac	70	FWJ-70A	√
MP45A5R	AC fuse provides protection				
MP75A4R	FWJ series American round fuse	1000 Vac	125	FWJ-125A	√
MP75A5R	AC fuse provides protection				
MP105A4R	FWJ series American round fuse	1000 Vac	175	FWJ-175A	√
MP105A5R	AC fuse provides protection				
MP155A4R	FWJ series American round fuse	1000 Vac	250	FWJ-250A	√
MP155A5R	AC fuse provides protection				
MP210A4R	FWJ series American round fuse	1000 Vac	350	FWJ-350A	√
MP210A5R	AC fuse provides protection				

**NOTE**

The above DC fuse recommendations are not required for UL conformity of the Mentor MP drive. Any installations required to meet NEC and/or UL508a panel requirements, must use recognized fuses that meet the requirements of the standard being applied. The UL columns above indicate whether the recommended fuse is a UL recognized component and not its conformance to either NEC or UL508a.

DC protection fusing is only required for 4 quadrant drives.

**Table 12-26 Cooper Bussman Semiconductor fusing for size 2 drives (alternative 1)**

Model	Description	Catalog No.	UL app	Alternative 1		
				Description	Catalog No.	UL app
Auxiliary	10 x 38 mm ferrule	FWC-25A10F				
MP350A4	690 V, 500 A BS88 fuse	500FMM	√	700 V, 500 A FWP Series fuse	FWP-500A	√
MP350A4R	Size 3 US blade SQ body	170M8536				
MP350A5	690 V, 500 A BS88 fuse	500FMM	√	700 V, 500 A FWP Series fuse	FWP-500A	√
MP350A6	690 V, 500 A BS88 fuse	500FMM		700 V, 500 A FWP Series fuse	FWP-500A	
MP350A5R	Size 2 Square Body DIN 43 653 fuse	170M5144	√			
MP350A6R	Size 2 Square Body DIN 43 653 fuse	170M5144				
MP420A4	690 V, 630 A BS88 fuse	630FMM	√	700 V, 700 A FWP Series fuse	FWP-700A	√
MP420A4R	Size 2 Square body DIN 43 653	170M5972				
MP470A5	*2 x Size 2 Square body DIN 43 653 in parallel	170M5139		700 V, 800 A FWP Series fuse	FWP-800A	
MP470A6						
MP470A5R						
MP470A6R						
MP550A4R	2 x Size 3 Square body DIN 43 653 in parallel.	170M8616				
MP700A4	Size 1 Square body flush end	170M4419		700 V, 900 A FWP Series fuse	FWP-900A	√
MP700A4R	Size 3 Square DIN 43 653 fuse	170M6147				
MP700A5	Size 2 Square body flush end	170M5415	√	700 V, 900 A FWP Series fuse	FWP-900A	√
MP700A6						

Model	Description	Catalog No.	UL app	Alternative 1		
				Description	Catalog No.	UL app
MP700A5R	Square body flush end contact	170M6726				
MP700A6R						
MP825A4	Size 2 Square body flush end	170M5417	√	700 V, 1200 A FWP Series Fuse	FWP-1200A	√
MP825A5						
MP825A6						
MP825A4R	2 x Size 3 Square Body DIN 43 653 in parallel.	170M6143				
MP825A5R	Square body flush end contact	170M6024				
MP825A6R						
MP900A4	Size 3 Square body flush end	170M6416	√	700 V, 1200 A FWP Series Fuse	FWP-1200A	√
MP900A4R	*Size 3 Square DIN 43 653 Fuse	*170M6147	√			
MP1200A4	Size 4 Square body flush end	170M7061				
MP1200A4R	2x Size 3 Square Body DIN 43 653 in parallel	170M6146				
MP1200A5	Size 4 Square body flush end	170M7061				
MP1200A6						
MP1200A5R	*2 x Square body flush end contact in parallel	*170M6726				
MP1200A6R						
MP1850A4	2 x Size 4 Square body flush end in parallel	170M7059				
MP1850A4R						
MP1850A5	*2 x Size 2 Square Body Flush End in parallel.	*170M5415				
MP1850A6						
MP1850A5R	*3 x Size 3 Square body DIN 43 653 in parallel.	*170M6143				
MP1850A6R						

**Table 12-27 Cooper Bussman Semiconductor fusing for size 2 drives (alternative 2)**

Model	Description	Catalog No.	UL app	Alternative 2		
				Description	Catalog No.	UL app
Auxiliary	10 x 38 mm ferrule	FWC-25A10F				
MP350A4	690 V, 500 A BS88 fuse	500FMM	√	1000 V, 500 A FWJ series fuse	FWJ-500A	√
MP350A4R	Size 3 US blade SQ body	170M8536				
MP350A5	690 V, 500 A BS88 fuse	500FMM	√	1000 V, 500 A FWJ series fuse	FWJ-500A	√
MP350A6						
MP350A5R	Size 2 Square Body DIN 43 653 fuse	170M5144	√			
MP350A6R						
MP420A4	690 V, 630 A BS88 fuse	630FMM	√	1000 V, 600 A FWJ series fuse	FWJ-600A	√
MP420A4R	Size 2 Square body DIN 43 653	170M5972		1000 V, 600 A FWJ series fuse	FWJ-600A	√
MP470A5	*2 x Size 2 Square body DIN 43 653 in parallel	170M5139		1000 V, 800 A FWJ Series Fuse	FWJ-800A	
MP470A6						
MP470A5R						
MP470A6R						
MP550A4R	2 x Size 3 Square body DIN 43 653 in parallel	170M8616		1000 V, 800 A FWJ series fuse	FWJ-800A	
MP700A4	Size 1 Square body flush end	170M4419		1000 V, 1000 A FWJ series fuse	FWJ-1000A	
MP700A4R	Size 3 Square DIN 43 653 fuse	170M6147				
MP700A5	Size 2 Square body flush end	170M5415	√			
MP700A6	Size 2 Square body flush end					
MP700A5R	Square body flush end contact	170M6726				
MP700A6R						
MP825A4	Size 2 Square body flush end	170M5417	√	1000 V, 1200 A FWJ series fuse	FWJ-1200A	
MP825A5	Size 2 Square body flush end					
MP825A6	Size 2 Square body flush end					
MP825A4R	2 x Size 3 Square body DIN 43 653 in parallel	170M6143		*1000 V, 1000 A FWJ series fuse	*FWJ-1000A	
MP825A5R	Square body flush end contact	170M6024				
MP825A6R						
MP900A4	Size 3 Square body flush end	170M6416	√	1000 V, 1200 A FWJ series fuse	FWJ-1200A	
MP900A4R	*Size 3 Square DIN 43 653 fuse	*170M6147	√	*1000 V, 1000 A FWJ series fuse	*FWJ-1000A	
MP1200A4	Size 4 Square body flush end	170M7061				

Model	Description	Catalog No.	UL app	Alternative 2		
				Description	Catalog No.	UL app
MP1200A4R	2x Size 3 Square body DIN 43 653 in parallel	170M6146		1000 V, 1600 A FWJ series fuse	FWJ-1600A	
MP1200A5	Size 4 Square body flush end	170M7061		1000 V, 1600 A FWJ Series fuse	FWJ-1600A	
MP1200A6						
MP1200A5R	*2 x Square body flush end contact in parallel	*170M6726				
MP1200A6R						
MP1850A4	2 x Size 4 Square body flush end in parallel	170M7059				
MP1850A4R				*2 x 1000 V, 1000 A FWJ Series fuses in parallel.	*FWJ-1000A	
MP1850A5	*2 x Size 2 Square body flush end in parallel	*170M5415				
MP1850A6						
MP1850A5R	*3 x Size 3 Square body DIN 43 653 in parallel	*170M6143				
MP1850A6R						

**Table 12-28 Cooper Bussman Semiconductor fusing for size 2 drives (alternative 3)**

Model	Description	Catalog No.	UL app	Alternative 3		
				Description	Catalog No.	UL app
Auxiliary	10 x 38 mm ferrule	FWC-25A10F				
MP350A4	690 V, 500 A BS88 fuse	500FMM	√	500 V, 450 A FWH Series fuse	FWH-450A	√
MP350A4R	Size 3 US blade SQ body	170M8536				
MP350A5	690 V, 500 A BS88 fuse	500FMM	√			
MP350A6	690 V, 500 A BS88 fuse	500FMM				
MP350A5R	Size 2 Square Body DIN 43 653 fuse	170M5144	√			
MP350A6R	Size 2 Square Body DIN 43 653 fuse	170M5144				
MP420A4	690 V, 630 A BS88 fuse	630FMM	√	500 V, 600 A FWH Series fuse	FWH-600A	√
MP420A4R	Size 2 Square Body DIN 43 653	170M5972				
MP470A5	*2 x Size 2 Square body DIN 43 653 in parallel	170M5139				
MP470A6						
MP470A5R						
MP470A6R						
MP550A4R	2 x Size 3 Square body DIN 43 653 in parallel	170M8616				
MP700A4	Size 1 Square body flush end	170M4419		500 V, 1000 A FWH Series fuse	FWH-1000A	√
MP700A4R	Size 3 Square DIN 43 653 Fuse	170M6147				
MP700A5	Size 2 Square body flush end	170M5415	√			

Model	Description	Catalog No.	UL app	Alternative 3		
				Description	Catalog No.	UL app
MP700A6	Size 2 Square body flush end	170M5415				
MP700A5R	Square body flush end contact	170M6726				
MP700A6R						
MP825A4	Size 2 Square body flush end	170M5417	√	500 V, 1200 A FWH Series fuse	FWH-1200A	√
MP825A5	Size 2 Square body flush end					
MP825A6	Size 2 Square body flush end					
MP825A4R	2 x Size 3 Square body DIN 43 653 in parallel	170M6143				
MP825A5R	Square body flush end contact	170M6024				
MP825A6R						
MP900A4	Size 3 Square body flush end	170M6416	√	500 V, 1200 A FWH Series fuse	FWH-1200A	√
MP900A4R	*Size 3 Square DIN 43 653 fuse	*170M6147	√			
MP1200A4	Size 4 Square body flush end	170M7061		2 x 500 V, 1000 A FWH Series fuse in parallel	FWH-1000A (x2)	
MP1200A4R	2x Size 3 Square body DIN 43 653 in parallel	170M6146				
MP1200A5	Size 4 Square body flush end	170M7061				
MP1200A6						
MP1200A5R	*2 x Square body flush end contact in parallel	*170M6726				
MP1200A6R						
MP1850A4	2 x Size 4 Square body flush end in parallel	170M7059		2 x 500 V, 1200 A FWH Series fuse in parallel	FWH-1200A (x2)	
MP1850A4R						
MP1850A5	*2 x Size 2 Square body flush end in parallel	*170M5415				
MP1850A6						
MP1850A5R	*3 x Size 3 Square body DIN 43 653 in parallel	*170M6143				
MP1850A6R						

**NOTE**

\*Fusing limits applications to those operating at rated current. No cyclic overloads are permitted.

**Table 12-29 Cooper Bussman branch circuit protection fusing for size 2 drives**

Model			Description	Catalog number	UL approved
Auxiliary			Class CC, 600 Vac, 20 A fuse		√
MP350A4	MP350A4R		Class L, 600 Vac, 900 A fuse	KRP-C-900SP	√
MP350A6	MP350A5R	MP350A6R			
MP420A4	MP420A4R		Class L, 600 Vac, 1200 A fuse	KRP-C-1200SP	√
MP470A6	MP470A5R	MP470A6R			
MP550A4	MP550A4R		Class L, 600 Vac, 1350 A fuse	KRP-C-1350SP	√
MP700A4	MP700A4R		Class L, 600 Vac, 1600 A fuse	KRPC-1600SP	√
MP700A6	MP700A5R	MP700A6R			
MP825A4	MP825A4R		Class L, 600 Vac, 2000 A fuse	KRP-C-2000SP	√
MP825A6	MP825A5R	MP825A6R			
MP900A4	MP900A4R		Class L, 600 Vac, 2000 A fuse	KRP-C-2000SP	√
MP1200A6	MP1200A5R	MP1200A6R			
MP1850A4	MP1850A4R		Class L, 600 Vac, 4500 A fuse	KRP-C-4500SP	√

**Table 12-30 Cooper Bussmann DC protection fusing for size 2 drives (alternative 1)**

Model	Description	Catalog No.	UL recog	Alternative 1		
				Description	Catalog No.	UL recog
MP350A4R	1000 V, 550 A US SQ Body fuse	170M8536		1000 V, 600 A FWJ Series fuse	FWJ-600	√
MP420A4R	1000 V, 800 A FWJ Series fuse	FWJ-800		1000 V, 800 A FWJ Series fuse	FWJ-800	
MP550A4R	1000 V, 900 A SQ Body end contact fuse	170M6603		1000 V, 1000 A FWJ Series fuse	FWJ-1000	
MP350A5R	1500 V, 630 A SQ Body end contact fuse	170M6726				
MP350A6R	1500 V, 630 A SQ Body end contact fuse	170M6726				
MP470A5R	1500 V, 900 A SQ Body end contact fuse	170M6727				
MP470A6R	1500 V, 900 A SQ Body end contact fuse	170M6727				
MP700A4R	1000 V, 1200 A FWJ Series fuse	FWJ-1200A		700 Vac 900 A FWP Series fuse	FWP 900A	√
MP825A4R	1000 V, 1400 A FWJ Series fuse	FWJ-1400A		700 Vac 1200 A FWP Series fuse	FWP 1200A	√
MP900A4R	1000 V, 1400 A FWJ Series fuse	FWJ-1400A		700 Vac 1200 A FWP Series fuse	FWP 1200A	√
MP700A5R	1500 V, 1260 A Double body fuse	170M6757				
MP700A6R	1500 V, 1260 A Double body fuse	170M6757				
MP825A5R	1500 V, 1260 A Double body fuse	170M6757				
MP825A6R	1500 V, 1260 A Double body fuse	170M6757				
MP1200A4R	1000 V, 2000 A FWJ Series fuse	FWJ-2000		2 x 700 Vac, 1000 A FWP fuses in parallel	FWP 1000A	
MP1850A4R	1000 V, 3000 A End contact fuse	170M7680		2 x 700 Vac, 1200 A FWP fuses in parallel	FWP 1200A	
MP1200A5R	1400 V, 2000 A SQ Body end contact fuse	170M8112				
MP1200A6R	1400 V, 2000 A SQ Body end contact fuse	170M8112				
MP1850A5R	1400 V, 3000 A SQ Body end contact fuse	170M8163				
MP1850A6R	1400 V, 3000 A SQ Body end contact fuse	170M8163				

**NOTE**

The above DC fuse recommendations are not required for UL conformity of the Mentor MP drive. Any installations required to meet NEC and/or UL508a panel requirements, must use recognized fuses that meet the requirements of the standard being applied. The UL columns above indicate whether the recommended fuse is a UL recognized component and not its conformance to either NEC or UL508a.

DC fusing is only required on four quadrant (R) drives.

**Table 12-31 Cooper Bussmann DC protection fusing for size 2 drives (alternative 2)**

Model	Description	Catalog No.	UL recog	Alternative 2		
				Description	Catalog No.	UL recog
MP350A4R	1000 V, 550 A US SQ Body fuse	170M8536		700 V, 450 A FWP Series Fuse	FWP 450A	√
MP420A4R	1000 V, 800 A FWJ Series fuse	FWJ-800		700 V, 600 A FWP Series Fuse	FWP 600A	√
MP550A4R	1000 V, 900 A SQ Body end contact fuse	170M6603		700 V, 700 A FWP Series Fuse	FWP 700A	√
MP350A5R	1500 V, 630 A SQ Body end contact fuse	170M6726				
MP350A6R	1500 V, 630 A SQ Body end contact fuse	170M6726				
MP470A5R	1500 V, 900 A SQ Body end contact fuse	170M6727				
MP470A6R	1500 V, 900 A SQ Body end contact fuse	170M6727				
MP700A4R	1000 V, 1200 A FWJ Series fuse	FWJ-1200A				
MP825A4R	1000 V, 1400 A FWJ Series fuse	FWJ-1400A				
MP900A4R	1000 V, 1400 A FWJ Series fuse	FWJ-1400A				
MP700A5R	1500 V, 1260 A Double body fuse	170M6757				
MP700A6R	1500 V, 1260 A Double body fuse	170M6757				
MP825A5R	1500 V, 1260 A Double body fuse	170M6757				
MP825A6R	1500 V, 1260 A Double body fuse	170M6757				
MP1200A4R	1000 V, 2000 A FWJ Series fuse	FWJ-2000				
MP1850A4R	1000 V, 3000 A End contact fuse	170M7680				
MP1200A5R	1400 V, 2000 A SQ Body end contact fuse	170M8112				
MP1200A6R	1400 V, 2000 A SQ Body end contact fuse	170M8112				
MP1850A5R	1400 V, 3000 A SQ Body end contact fuse	170M8163				
MP1850A6R	1400 V, 3000 A SQ Body end contact fuse	170M8163				

**NOTE**

The above DC fuse recommendations are not required for UL conformity of the Mentor MP drive. Any installations required to meet NEC and/or UL508a panel requirements, must use recognized fuses that meet the requirements of the standard being applied. The UL columns above indicate whether the recommended fuse is a UL recognized component and not its conformance to either NEC or UL508a. DC fusing is only required on four quadrant (R) drives.



**Siba**

**Table 12-32 Siba semiconductor fusing for 480 V and 575 V size 1 drives**

Model		Fuse type	Rating V	Rating A	Part No. (with indicator)	Part No. (without indicator)	UL approved
Auxiliary		10 x 38 mm Ferrule fuse	660 Vac	12		50 179 06.12	
MP25A4	MP25A5	22 x 58 cylindrical 690 Vac URZ	690 Vac	32		50 140 06.32	√
MP45A4	MP45A5			63		50 140 06.63	√
MP75A4	MP75A5			100		50 140 06.100	√
MP25A4(R)	MP25A5(R)			32		50 140 06.32	√
MP45A4(R)	MP45A5(R)			63		50 140 06.63	√
MP75A4(R)	MP75A5(R)			100		50 140 06.100	√
MP105A4	MP105A5			URB 000 690 Vac 160 A bolt-type	160	20 282 20.160	20 282 21.160
MP155A4	MP155A5	URB 000 690 Vac 200 A bolt-type	200	20 282 20.200	20 282 21.200	√	
MP210A4	MP210A5	URB 000 690 Vac 315 A bolt-type	315	20 282 20.315	20 282 21.315	√	
MP105A4(R)	MP105A5(R)	URB 000 690 Vac 160 A bolt-type	160	20 282 20.160	20 282 21.160	√	
MP155A4(R)	MP155A5(R)	URB 000 690 Vac 200 A bolt-type	200	20 282 20.200	20 282 21.200	√	
MP210A4(R)	MP210A5(R)	URB 000 690 Vac 315 A bolt-type	315	20 282 20.315	20 282 21.315	√	

**Table 12-33 Siba branch circuit protection fusing for 480 V and 575 V size 1 drives**

Model		Rating V	Rating A	Description	Part number	UL approved
Auxiliary		690 Vac	10	NH 000 gG 690 Vac 10 A	20 477 13.10	
MP25A4	MP25A5		35	NH 000 gG 690 Vac 35 A	20 477 13.35	
MP45A4	MP45A5		63	NH 00 gG 690 Vac 63 A	20 209 13.63	
MP75A4	MP75A5		100	NH 00 gG 690 Vac 100 A	20 209 13.100	
MP25A4(R)	MP25A5(R)		35	NH 000 gG 690 Vac 35 A	20 477 13.35	
MP45A4(R)	MP45A5(R)		63	NH 00 gG 690 Vac 63 A	20 209 13.63	
MP75A4(R)	MP75A5(R)		100	NH 00 gG 690 Vac 100 A	20 209 13.100	
MP105A4	MP105A5		160	NH1 gG 690 Vac 160 A	20 211 13.160	
MP155A4	MP155A5		200	NH1 gG 690 Vac 200 A	20 211 13.200	
MP210A4	MP210A5		315	NH2 gG 690 Vac 315 A	20 212 13.315	
MP105A4(R)	MP105A5(R)		160	NH1 gG 690 Vac 160 A	20 211 13.160	
MP155A4(R)	MP155A5(R)		200	NH1 gG 690 Vac 200 A	20 211 13.200	
MP210A4(R)	MP210A5(R)		315	NH2 gG 690 Vac 315 A	20 212 13.315	

**Table 12-34 Siba DC protection fusing for 480 V and 575 V size 1 drives**

Model		Rating V	Rating A	Description	Reference number	Configuration	UL approved
MP25A4R	MP25A5R	1000 Vdc	32	20 x 127 1000 Vdc 32 A gR	90 080 10.32	Single fuse	
MP45A4R	MP45A5R		50	20 x 127 1000 Vdc 50 A gR	90 080 10.50		
MP75A4R	MP75A5R	1500 Vdc	80	36 x 190 1500 Vdc 80 A gR	90 094 10.80		
MP105A4R	MP105A5R	900 Vdc	125	SQB-DC2 1200 V 125 A	90 203 25.125		
MP155A4R	MP155A5R		160	SQB-DC2 1200 V 160 A	90 203 25.160		
MP210A4R	MP210A5R		250	SQB-DC2 1200 V 250 A	90 203 25.250		

**NOTE**

The above DC fuse recommendations are not required for UL conformity of the Mentor MP drive. Any installations required to meet NEC and/or UL508a panel requirements, must use recognized fuses that meet the requirements of the standard being applied. The UL columns above indicate whether the recommended fuse is a UL recognized component and not its conformance to either NEC or UL508a.

DC fusing is only required on four quadrant (R) drives.

**Table 12-35 Siba Semiconductor fusing for size 2 drives**

Model	Description	International				USA	
		Part number					
		Metric thread contact	UL app	Blade contact	UL app	Blade contact	UL app
Auxiliary	10 x 38 mm Ferrule fuse	50 179 06.20					
MP350A4	690 V SQB1 500 A	20 660 31.500	√	20 610 31.500	√	20 617 31.500	√
MP420A4	690 V SQB1 550 A	20 660 31.550	√	20 610 31.550	√	20 617 31.550	√
MP550A4	2 x 690 V SQB1 400 A in parallel	20 660 31.400		20 610 31.400		20 617 31.400	
MP350A4R	690 V SQB1 500 A	20 660 31.500	√	20 610 31.500	√	20 617 31.500	√
MP420A4R	690 V SQB1 550 A	20 660 31.550		20 610 31.550		20 617 31.550	
MP550A4R	2 x 690 V SQB1 400 A in parallel	20 660 31.400		20 610 31.400		20 617 31.400	
MP350A5	1250 V SQB1 450 A	20 760 31.450	√	20 713 31.450	√	20 719 31.450	√
MP350A6	1250 V SQB1 450 A	20 760 31.450		20 713 31.450		20 719 31.450	
MP470A5	2 x 1250 V SQB3 350 A in parallel	20 780 31.350		20 733 31.350		20 739 31.350	
MP470A6	2 x 1250 V SQB3 350 A in parallel	20 780 31.350		20 733 31.350		20 739 31.350	
MP350A5R	1250 V SQB1 450 A	20 760 31.450	√	20 713 31.450	√	20 719 31.450	√
MP350A6R	1250 V SQB1 450 A	20 760 31.450		20 713 31.450		20 719 31.450	
MP470A5R	2 x 1250 V SQB3 350 A in parallel	20 780 31.350		20 733 31.350		20 739 31.350	
MP470A6R	2 x 1250 V SQB3 350 A in parallel	20 780 31.350		20 733 31.350		20 739 31.350	
MP700A4	690 V SQB1 900 A	20 660 31.900		20 610 31.900		20 617 31.900	
MP825A4	2 x 690 V SQB2 630 A in parallel	20 670 31.630		20 620 31.630		20 627 31.630	
MP900A4	690 V SQB2-2 1250 A	20 678 32.1250					
MP700A4R	690 V SQB1 900 A	20 660 31.900		20 610 31.900		20 617 31.900	
MP825A4R	2 x 690 V SQB2 630 A in parallel	20 670 31.630		20 620 31.630		20 627 31.630	
MP900A4R	690 V SQB2-2 1250 A	20 678 32.1250					
MP700A5	*1250 V SQB3 900 A	20 780 31.900	√	20 733 31.900	√	20 739 31.900	√
MP700A6	*1250 V SQB3 900 A	20 780 31.900		20 733 31.900		20 739 31.900	
MP825A5	1250 V SQB2 800 A	*20 770 31.800	√	*20 723 31.800	√	*20 729 31.800	√
MP825A6	1250 V SQB2 800 A	*20 770 31.800		*20 723 31.800		*20 729 31.800	
MP700A5R	1250 V SQB3 900 A	20 780 31.900	√	20 733 31.900	√	20 739 31.900	√
MP700A6R	1250 V SQB3 900 A	20 780 31.900		20 733 31.900		20 739 31.900	
MP825A5R	*1250 V SQB2 800 A	*20 770 31.800	√	*20 723 31.800	√	*20 729 31.800	√
MP825A6R	*1250 V SQB2 800 A	*20 770 31.800		*20 723 31.800		*20 729 31.800	
MP1200A4	690 V SQB2-2 1600 A	20 678 32.1600					
MP1850A4	*690 V SQB3-2 1800 A	*20 688 32.1800					
MP1200A5	2 x 1250 V SQB3-2 900 A in parallel	20 788 32.900					
MP1200A6	2 x 1250 V SQB3-2 900 A in parallel	20 788 32.900					
MP1850A5	**2 x 1250 V SQB3-2 900 A in parallel	**20 788 32.900					
MP1850A6	**2 x 1250 V SQB3-2 900 A in parallel	**20 788 32.900					
MP1200A4R	690 V SQB2-2 1600 A	20 678 32.1600					
MP1850A4R	*690 V SQB3-2 1800 A	*20 688 32.1800					
MP1200A5R	2 x 1250 V SQB3-2 900 A in parallel	20 788 32.900					
MP1200A6R	2 x 1250 V SQB3-2 900 A in parallel	20 788 32.900					
MP1850A5R	**2 x 1250 V SQB3-2 900 A in parallel	**20 788 32.900					
MP1850A6R	**2 x 1250 V SQB3-2 900 A in parallel	**20 788 32.900					

**NOTE**

\*Applications limited to 100 % current ripple content and no cyclic overloads to avoid fuse wear-out.

\*\*Applications limited to 30 % current ripple content and no cyclic overloads to avoid fuse wear-out.

**Table 12-36 Siba branch circuit fusing for size 2 drives**

Model	International		
	Description	Part number	UL approved
Auxiliary	*500 Vac, 20 A gG NH-Knife Blade	20 000 13.20	
	690 Vac, 20 A gG NH-Knife Blade	20 477 13.20	
MP350A4(R)	*500 Vac, 355 A gG NH-knife blade	20 004 13.355	
	690 Vac, 355 A gG NH-knife blade	20 212 13.355	
MP350A5(R)	690 Vac, 355 A gG NH-knife blade	20 212 13.355	
MP350A6(R)			
MP420A4(R)	*500 Vac, 400 A gG NH-knife blade	20 004 13.400	
	690 Vac, 400 A gG NH-knife blade	20 212 13.400	
MP470A5(R)	690 Vac, 630 A gG NH-knife blade	20 225 13.630	
MP470A6(R)			
MP550A4(R)	690 Vac, 630 A gG NH-knife blade	20 225 13.630	
MP700A4(R)	*500 Vac, 800 A gG NH-knife blade	20 006 13.800	
	690 Vac, 800 A gG NH-knife blade	20 225 13.800	
MP700A5(R)	690 Vac, 800 A gG NH-knife blade	20 225 13.800	
MP700A6(R)			
MP825A4(R)	690 Vac, 800 A gG NH-knife blade	20 225 13.800	
MP825A5(R)			
MP825A6(R)			
MP900A4(R)	*500 Vac, 1250 A gG NH-knife blade	20 006 13.1250	
MP1200A4(R)	*500 Vac, 1250 A gG NH-knife blade	20 006 13.1250	

**NOTE**

Fuses are only rated up to 500 Vac.

**Table 12-37 Siba DC protection fusing for size 2 drives**

Model	Description	International				USA			
		Part number							
		Metric thread	UL	Blade contact	UL	UNC thread	UL	Blade contact	UL
MP350A4R	2 x SQB3 1250 V 315 A in parallel	2078132.315A.		2073532.315A		2078432.315A		2073932.315A	
MP350A5R	SQB3 1250 V 400 A	*2078132.400A.	√	*2073532.400A	√	*2078432.400A	√	*2073932.400A	√
MP350A6R	SQB3 1250 V 400 A	*2078132.400A.	√	*2073532.400A	√	*2078432.400A	√	*2073932.400A	√
MP420A4R	SQB3 1250 V 500 A	*2078132.500A	√	*2073532.500A	√	*2078432.500A	√	*2073932.500A	√
MP470A5R	2 x SQB3 1250 V 315 A in parallel	*2078132.315A.		*2073532.315A		*2078432.315A		*2073932.315A	
MP470A6R	2 x SQB3 1250 V 315 A in parallel	*2078132.315A.		*2073532.315A		*2078432.315A		*2073932.315A	
MP550A4R	2 x SQB3 1250 V 315 A in parallel	*2078132.315A.		*2073532.315A		*2078432.315A		*2073932.315A	
MP700A4R	2 x SQB3 1250 V 500 A in parallel	2078132.500A		2073532.500A		2078432.500A		2073932.500A	
MP700A5R	2 x SQB3 1250 V 450 A in parallel	*2078132.450A		*2073532.450A		*2078432.450A		*2073932.450A	
MP700A6R	2 x SQB3 1250 V 450 A in parallel	*2078132.450A		*2073532.450A		*2078432.450A		*2073932.450A	
MP825A4R	2 x SQB3 1250 V 500 A in parallel	*2078132.500A		*2073532.500A		*2078432.500A		*2073932.500A	
MP825A5R	2 x SQB3 1250 V 500 A in parallel	*2078132.500A		*2073532.500A		*2078432.500A		*2073932.500A	
MP825A6R	2 x SQB3 1250 V 500A in parallel	*2078132.500A		*2073532.500A		*2078432.500A		*2073932.500A	
MP900A4R	2 x SQB3 1250 V 500 A in parallel	*2078132.500A		*2073532.500A		*2078432.500A		*2073932.500A	

**NOTE**

\* Applications limited to 100 % current ripple content and no cyclic overloads to avoid fuse wear-out.  
DC fusing is only required on four quadrant (R) drives.

**NOTE**

The above DC fuse recommendations are not required for UL conformity of the Mentor MP drive. Any installations required to meet NEC and/or UL508a panel requirements, must use recognized fuses that meet the requirements of the standard being applied. The UL columns above indicate whether the recommended fuse is a UL recognized component and not its conformance to either NEC or UL508a.

**Table 12-38 Mentor MP size 1 drive thyristor  $I^2t$  rating for semiconductor fusing**

Model	Thyristor $I^2t$ (A <sup>2</sup> s)	Latching current IL (mA)	Holding current IH (mA)
Field regulator	400		
MP25A4 MP25A5 MP25A4(R) MP25A5(R)	1030		
MP45A4 MP45A5 MP45A4(R) MP45A5(R)	3600	450	200
MP75A4 MP75A5 MP75A4(R) MP75A5(R)	15000		
MP105A4 MP105A5 MP105A4(R) MP105A5(R)			
MP155A4 MP155A5	80000	300	200
MP210A4 MP210A5			
MP155A4(R) MP155A5(R)			
MP210A4(R) MP210A5(R)			

**Table 12-39 Mentor MP size 2 drive thyristor  $I^2t$  ratings for semiconductor fusing**

Model	Thyristor $I^2t$ (A <sup>2</sup> s)	Latching current IL (mA)	Holding current IH (mA)
Field regulator	400		
MP350A4(R) MP550A4(R) MP420A4(R)	320000	200	150
MP350A6(R) MP470A6(R) MP470A5(R)	281000		
MP700A4(R) MP900A4(R) MP825A4(R)	1050000	300 - 2000	150 - 500
MP700A6(R) MP825A6(R) MP825A5(R)	1200000		
MP1200A4(R) MP1200A6(R) MP1200A5(R)	2720000	2000	1000
MP1850A4(R) MP1850A6(R) MP1850A5(R)			

### 12.2.3 Torque settings

**Table 12-40 Drive control, status relay and encoder terminal data**

Model	Connection type	Torque setting
All	Plug-in terminal block	0.5 N m (4.5 lb in)

**Table 12-41 Drive auxiliary and machine armature terminal data**

Model	Connection type	Torque setting
All	Terminal block	0.5 N m (4.5 lb in)

**Table 12-42 Drive power stage terminals on size 1 drives**

Model	Connection type	Torque setting
All	M8 stud	10 N m (89.0 lb in)

**Table 12-43 Drive power stage terminals on size 2 drives**

Model	Connection type	Torque setting
Size 2A	M10 stud	15 N m (133.0 lb in)
Size 2B		
Size 2C	M12 stud	30 N m (266.0 lb in)
Size 2D		

## 12.2.4 Electromagnetic compatibility (EMC)

This is a summary of the EMC performance of the drive. For full details, refer to the Mentor MP EMC data sheet which can be obtained from the supplier of the drive.

**Table 12-44 Immunity compliance**

Standard	Type of immunity	Test specification	Application	Level
IEC 61000-4-2 EN 61000-4-2	Electrostatic discharge	6 kV contact discharge 8 kV air discharge	Module enclosure	Level 3 (industrial)
IEC 61000-4-3 EN 61000-4-3	Radio frequency radiated field	10 V/m prior to modulation 80 - 1000 MHz 80 % AM (1 kHz) modulation	Module enclosure	Level 3 (industrial)
IEC 61000-4-4 EN 61000-4-4	Fast transient burst	5/50 ns 2 kV transient at 5 kHz repetition frequency via coupling clamp	Control lines	Level 4 (industrial harsh)
		5/50 ns 2 kV transient at 5 kHz repetition frequency by direct injection	Power lines	Level 3 (industrial)
IEC 61000-4-5 EN 61000-4-5	Surges	Common mode 4 kV 1.2/50 $\mu$ s waveshape	AC supply lines: line to ground	Level 4
		Differential mode 2 kV 1.2/50 $\mu$ s waveshape	AC supply lines: line to line	Level 3
		Lines to ground	Signal ports to ground <sup>1</sup>	Level 2
IEC 61000-4-6 EN 61000-4-6	Conducted radio frequency	10V prior to modulation 0.15 - 80 MHz 80 % AM (1 kHz) modulation	Control and power lines	Level 3 (industrial)
IEC 61000-4-11 EN 61000-4-11	Voltage dips and interruptions	-30 % 10 ms +60 % 100 ms -60 % 1s <-95 % 5s	AC power ports	
EN 61000-6-1:2007 IEC 61000-6-1	Generic immunity standard for the residential, commercial and light - industrial environment			Complies
IEC 61000-6-2 EN 61000-6-2:2005	Generic immunity standard for the industrial environment			Complies
IEC 61800-3 EN 61800-3:2004	Product standard for adjustable speed power drive systems (immunity requirements)		Meets immunity requirements for first and second environments	

<sup>1</sup> See section 4.9.4 *Surge immunity of control circuits - long cables and connections outside a building* on page 53 for control ports for possible requirements regarding grounding and external surge protection.

## Emission

The requirements of the following standards are met for motor cable lengths up to 100 m.

**Table 12-45 Emission compliance**

Model	Filter		
	None	Field: Standard Armature: Standard	Field: Standard Armature: High performance
MP25A4(R)	C4	C3	C2
MP45A4(R)			
MP75A4(R)			
MP105A4(R)			
MP155A4(R)			
MP210A4(R)			
MP350A4(R)			
MP420A4(R)			
MP550A4(R)			
MP700A4(R)			
MP825A4(R)			
MP900A4(R)			
MP1200A4(R)			
MP1850A4(R)			

**Key** (shown in decreasing order of permitted emission level):

- C4 EN 61800-3:2004 second environment, restricted distribution (Additional measures may be required to prevent interference)
- C3 EN 61800-3:2004 second environment, unrestricted distribution
- C2 Industrial generic standard EN 61000-6-4:2007  
EN 61800-3:2004 first environment restricted distribution (The following caution is required by EN 61800-3:2004)



This is a product of the restricted distribution class according to IEC 61800-3. In a residential environment this product may cause radio interference in which case the user may be required to take adequate measures.


- C1 Residential generic standard EN 61000-6-3:2007  
EN 61800-3:2004 first environment unrestricted distribution

EN 61800-3:2004 defines the following:

- The first environment is one that includes residential premises. It also includes establishments directly connected without intermediate transformers to a low-voltage power supply network which supplies buildings used for residential purposes.
- The second environment is one that includes all establishments other than those directly connected to a low-voltage power supply network which supplies buildings used for residential purposes.
- Restricted distribution is defined as a mode of sales distribution in which the manufacturer restricts the supply of equipment to suppliers, customers or users who separately or jointly have technical competence in the EMC requirements of the application of drives.

## 12.3 Optional external EMC filters

EMC filters can be sourced directly from Schaffner and Epcos. See Table 12-46 for details.

 <b>CAUTION</b>	<p>It is essential that line reactors be connected between the filter terminals and the power input terminals, as shown in Figure 4-1. Failure to observe this requirement could result in destruction of the thyristors.</p>
--	---

**Table 12-46 Mentor MP and EMC filter cross reference**

Model	Manufacturers part number				
	Schaffner armature standard	Schaffner armature high performance	Epcos armature high performance	Schaffner standard field filter	Epcos standard field filter
MP25A4(R)	FN3270H-80-35	FN3258-75-52	B84143-A66-R105	FN3280H-8-29	W62400-T1262D004
MP45A4(R)			*B84143-A90-R105		
MP75A4(R)					
MP105A4(R)	FN3270H-200-99	FN3258H-180-40	B84143BO250S080	FN3280H-25-33	
MP155A4(R)					
MP210A4(R)					
MP350A4 (R)					
MP420A4 (R)					
MP550A4 (R)	FN3359-800-99				
MP700A4 (R)					
MP825A4(R)					
MP900A4 (R)					
MP1200A4 (R)	FN3359-1600-99				
MP1850A4 (R)					

\* This filter is required if the input current to the Mentor MP will be greater than 66 Amps.



# 13 Diagnostics

The display on the drive gives various information about the status of the drive. These fall into three categories:

- Trip indications
- Alarm indications
- Status indications



Users must not attempt to repair a drive if it is faulty, nor carry out fault diagnosis other than through the use of the diagnostic features described in this chapter. If a drive is faulty, it must be returned to an authorized Control Techniques distributor for repair.

## 13.1 Trip indications

If the drive trips, the output of the drive is disabled so that the drive stops controlling the motor. The upper display indicates that a trip has occurred and the lower display shows the trip.

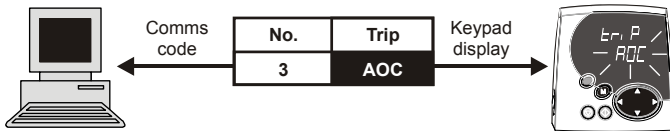
Trips are listed alphabetically in Table 13-1 based on the trip indication shown on the drive display. Refer to Figure 13-1.

If a display is not used, the drive LED Status indicator will flash if the drive has tripped. Refer to Figure 13-2.

The trip indication can be read in Pr 10.20 providing a trip number. Trip numbers are listed in numerical order in Table 13-2 so the trip indication can be cross referenced and then diagnosed using Table 13-1.

### Example

1. Trip code 3 is read from Pr 10.20 via serial communications.
2. Checking Table 13-2 shows Trip 3 is an AOC trip.



3. Look up AOC in Table 13-1.
4. Perform checks detailed under *Diagnosis*.

Figure 13-1 Keypad status modes

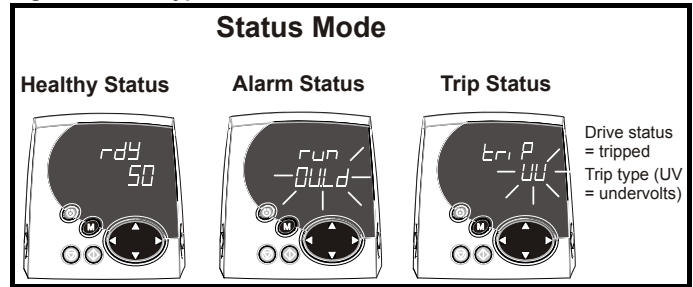


Figure 13-2 Location of the status LED

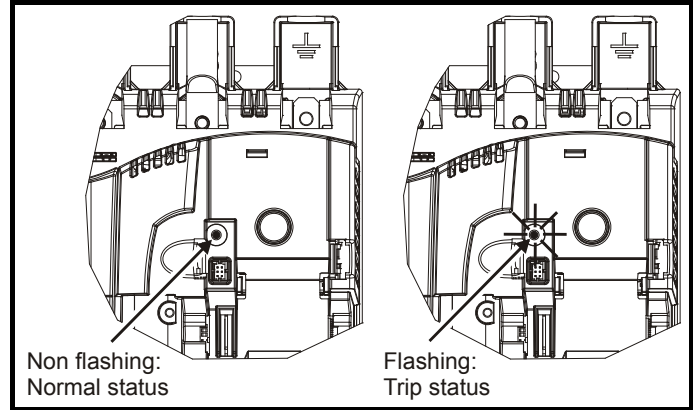


Table 13-1 Trip indications

Trip	Diagnosis
<b>AOC</b>	<b>Instantaneous output over current detected: Peak current greater than 225 %</b>
<b>3</b>	Check for short circuit on armature cabling Check integrity of motor insulation Check current loop stability
<b>AOP</b>	<b>Voltage has been applied to the armature but no current feedback has been detected</b>
<b>158</b>	Check the armature circuit
<b>AtL Err</b>	<b>Power processor armature timing loop cannot operate with the current PLL synchronization and the firing angle demand</b>
<b>161</b>	This can occur if the PLL is in the process of losing synchronization but has not yet asserted a PLL Err (trip 174).
<b>C.Acc</b>	<b>SMARTCARD trip: SMARTCARD Read / Write fail</b>
<b>185</b>	Check SMARTCARD is installed / located correctly Ensure SMARTCARD is not writing data to data location 500 to 999 Replace SMARTCARD
<b>C.boot</b>	<b>SMARTCARD trip: The menu 0 parameter modification cannot be saved to the SMARTCARD because the necessary file has not been created on the SMARTCARD</b>
<b>177</b>	A write to a menu 0 parameter has been initiated via the keypad with Pr 11.42 (SE09, 0.30) set to auto(3) or boot(4), but the necessary file on the SMARTCARD has not been created Ensure that Pr 11.42 (SE09, 0.30) is correctly set and reset the drive to create the necessary file on the SMARTCARD Re-attempt the parameter write to the menu 0 parameter
<b>C.bUSY</b>	<b>SMARTCARD trip: SMARTCARD can not perform the required function as it is being accessed by a Solutions Module</b>
<b>178</b>	Wait for the Solutions Module to finish accessing the SMARTCARD and then re-attempt the required function
<b>C.Chg</b>	<b>SMARTCARD trip: Data location already contains data</b>
<b>179</b>	Erase data in data location Write data to an alternative data location

Trip	Diagnosis
<b>C.cPr</b>	<b>SMARTCARD trip: The values stored in the drive and the values in the data block on the SMARTCARD are different</b>
188	Press the red  reset button
<b>C.dAt</b>	<b>SMARTCARD trip: Data location specified does not contain any data</b>
183	Ensure data block number is correct
<b>C.Err</b>	<b>SMARTCARD trip: SMARTCARD data is corrupted</b>
182	Ensure the card is located correctly Erase data and retry Replace SMARTCARD
<b>C.Full</b>	<b>SMARTCARD trip: SMARTCARD full</b>
184	Delete a data block or use different SMARTCARD
<b>cL2</b>	<b>Analog input 2 current loss (current mode)</b>
28	Check analog input 2 (terminal 7) current signal is present (4-20 mA, 20-4 mA)
<b>cL3</b>	<b>Analog input 3 current loss (current mode)</b>
29	Check analog input 3 (terminal 8) current signal is present (4-20 mA, 20-4 mA)
<b>CL.bit</b>	<b>Trip initiated from the control word (Pr 6.42)</b>
35	Disable the control word by setting Pr <b>6.43</b> to 0 or check setting of Pr <b>6.42</b>
<b>C.OPtn</b>	<b>SMARTCARD trip: Solutions Modules installed are different between source drive and destination drive</b>
180	Ensure correct Solutions Modules are installed Ensure Solutions Modules are in the same Solutions Module slot Press the red  reset button
<b>C.Prod</b>	<b>SMARTCARD trip: The data blocks on the SMARTCARD are not compatible with this product</b>
175	Erase all data on the SMARTCARD by setting Pr <b>xx.00</b> to 9999 and pressing the red  reset button Replace SMARTCARD
<b>C.Rdo</b>	<b>SMARTCARD trip: SMARTCARD has the Read Only bit set</b>
181	Enter 9777 in Pr <b>xx.00</b> to allow SMARTCARD Read / Write access Ensure the drive is not writing to data locations 500 to 999 on the card
<b>C.rtg</b>	<b>SMARTCARD trip: The voltage and/or current rating of the source and destination drives are different</b>
186	Parameter data or default difference data is being transferred from a SMARTCARD to the drive, but the current and /or voltage ratings are different between source and destination drives. This trip does not stop the data transfer, but is a warning that the data for the Solution Modules that are different will be set to the default values and not the values from the card. This trip also applies if a compare is attempted between the data block and the drive.
<b>C.TyP</b>	<b>SMARTCARD trip: SMARTCARD parameter set not compatible with drive</b>
187	Press the reset button Ensure destination drive type is the same as the source parameter file drive type
<b>dEst</b>	<b>Two or more parameters are writing to the same destination parameter</b>
199	Set Pr <b>xx.00</b> = 12001 check all visible parameters in the menus for duplication
<b>EEF</b>	<b>EEPROM data corrupted - Drive mode becomes open loop and serial comms will timeout with remote keypad on the drive RS485 comms port.</b>
31	This trip can only be cleared by loading default parameters and saving parameters
<b>EnC1</b>	<b>Drive encoder trip: Encoder power supply overload</b>
189	Check encoder power supply wiring and encoder current requirement Maximum current = 200 mA @ 15 V, or 300 mA @ 8 V and 5 V
<b>EnC2</b>	<b>Drive encoder trip: Wire break</b>
190	Check cable continuity Check wiring of feedback signals is correct Check encoder power supply is set correctly in Pr <b>3.36 (Fb06, 0.76)</b> Replace feedback device If wire break detection on the main drive encoder input is not required, set Pr <b>3.40</b> = 0 to disable the Enc2 trip
<b>EnC3</b>	<b>Drive encoder trip: Overload</b>
191	Overload

Trip	Diagnosis
<b>EnC9</b>	<b>Drive encoder trip: Position feedback is selected from a Solutions Module slot which does not have a speed / position feedback Solutions Module installed</b>
<b>197</b>	Check setting of Pr <b>3.26 (Fb01, 0.71)</b> (or Pr <b>21.21</b> if the second motor parameters have been enabled)
<b>EnC10</b>	<b>Drive encoder trip: Termination overload</b>
<b>198</b>	If the voltage from the encoder is >5 V, then the termination resistors must be disabled (Pr <b>3.39</b> to 0)
<b>Et</b>	<b>External trip</b>
<b>6</b>	Check terminal 31 signal Check value of Pr <b>10.32</b> Enter 12001 in Pr <b>xx.00</b> and check for parameter controlling Pr <b>10.32</b> Ensure Pr <b>10.32</b> or Pr <b>10.38 (=6)</b> are not being controlled by serial comms
<b>FbL</b>	<b>No feedback from the tachogenerator or encoder</b>
<b>159</b>	If the difference between the estimated speed (Pr <b>5.04</b> ) and the actual speed feedback (Pr <b>3.02 (di05, 0.40)</b> ) exceeds the value set in the speed feedback loss window (Pr <b>3.56</b> ) the drive will trip Feedback loss. With fast acceleration rates in applications with low load inertia estimated speed (Pr <b>5.04</b> ) may not track the actual speed feedback (Pr <b>3.02 (di05, 0.40)</b> ) fast enough and the speed feedback loss window (Pr <b>3.56</b> ) may need to be increased. Check the feedback device is connected correctly Check motor name plate values have been entered into the drive correctly Check the speed feedback in estimated speed mode - refer to running a motor section checking speed feedback Carry out a rotating autotune <b>NOTE</b> A rotating autotune optimizes the estimated speed value. Further adjustment of Pr <b>5.29</b> , Pr <b>5.30</b> and Pr <b>5.74</b> may be required to fully optimize estimated speed value.
<b>Fbr</b>	<b>The polarity of the feedback tachogenerator or encoder is incorrect</b>
<b>160</b>	Check that the feedback devices are connected correctly
<b>FdL</b>	<b>No current in the field supply circuit</b>
<b>168</b>	Check that the field controller (Pr <b>5.77 (SE12, 0.33)</b> ) is enabled. For the internal field controller check terminals L11, L12 are closed Check internal auxiliary fuses, refer to section on page 49.
<b>FOC</b>	<b>Excess current detected in field current feedback</b>
<b>169</b>	Maximum current feedback is present Check Field rated current (Pr <b>5.70 (SE10, 0.31)</b> ) and Field rated voltage (Pr <b>5.73 (SE11, 0.32)</b> ) are set correct to motor nameplate Check for short circuit on field circuit cabling Check integrity of motor insulation
<b>F.OVL</b>	<b>Field I<sup>2</sup>t overload</b>
<b>157</b>	See Pr <b>5.81</b> and Pr <b>5.82</b>
<b>HF01</b>	<b>Data processing error: CPU address error</b>
	Hardware fault - return drive to supplier
<b>HF02</b>	<b>Data processing error: DMAC address error</b>
	Hardware fault - return drive to supplier
<b>HF03</b>	<b>Data processing error: Illegal instruction</b>
	Hardware fault - return drive to supplier
<b>HF04</b>	<b>Data processing error: Illegal slot instruction</b>
	Hardware fault - return drive to supplier
<b>HF05</b>	<b>Data processing error: Undefined exception</b>
	Hardware fault - return drive to supplier
<b>HF06</b>	<b>Data processing error: Reserved exception</b>
	Hardware fault - return drive to supplier
<b>HF07</b>	<b>Data processing error: Watchdog failure</b>
	Hardware fault - return drive to supplier
<b>HF08</b>	<b>Data processing error: Level 4 crash</b>
	Hardware fault - return drive to supplier
<b>HF09</b>	<b>Data processing error: Heap overflow</b>
	Hardware fault - return drive to supplier

Trip	Diagnosis
<b>HF10</b>	<b>Data processing error: Router error</b>
	Hardware fault - return drive to supplier
<b>HF11</b>	<b>Data processing error: Access to EEPROM failed</b>
	Hardware fault - return drive to supplier
<b>HF12</b>	<b>Data processing error: Main program stack overflow</b>
	Hardware fault - return drive to supplier
<b>HF17</b>	<b>Data processing error: No Comms from power processor</b>
<b>217</b>	Hardware fault - return drive to supplier
<b>HF18</b>	<b>Bucket suppressor capacitor failure</b>
<b>218</b>	Hardware fault - return drive to supplier
<b>HF19</b>	<b>Overheat on bucket suppressor or snubber circuits</b>
<b>219</b>	Check internal fan operation
<b>HF20</b>	<b>Power stage recognition: identification code error</b>
<b>220</b>	Hardware fault - return drive to supplier
<b>HF21</b>	<b>Power processor: Watchdog failure</b>
<b>221</b>	Hardware fault - return drive to supplier
<b>HF22</b>	<b>Power processor: Undefined exception</b>
<b>222</b>	Hardware fault - return drive to supplier
<b>HF23</b>	<b>Power processor: Current control level 1 over-run</b>
<b>223</b>	Control loops within the current control have not been completed in the required time period. Hardware fault - return drive to supplier
<b>HF24</b>	<b>Power processor: Current control level 2 over-run</b>
<b>224</b>	Control loops within the current control have not been completed in the required time period. Hardware fault - return drive to supplier
<b>HF25</b>	<b>Power processor: Background over-run</b>
<b>225</b>	Control loops within the current control have not been completed in the required time period. Hardware fault - return drive to supplier
<b>HF27</b>	<b>Power circuit: Thermistor 1 fault</b>
<b>227</b>	Hardware fault - return drive to supplier
<b>HF28</b>	<b>Power software not compatible with user software</b>
<b>228</b>	Hardware fault - return drive to supplier
<b>HF29</b>	<b>User processor: Armature timing error</b>
<b>229</b>	Hardware fault - return drive to supplier
<b>It.AC</b>	<b><math>I^2t</math> on drive output current (Refer to Pr 4.16)</b>
<b>20</b>	Ensure the load is not jammed / sticking Check the load on the motor has not changed
<b>O.ht1</b>	<b>Drive overheat (thyristor junction) based on thermal model</b>
<b>21</b>	Reduce ambient temperature Reduce overload cycle
<b>O.ht2</b>	<b>Heatsink over temperature</b>
<b>22</b>	Check enclosure / drive fans are still functioning correctly Check enclosure ventilation paths Check enclosure door filters Increase ventilation Decrease acceleration / deceleration rates Reduce duty cycle Reduce motor load
<b>O.ht3</b>	<b>External discharge resistor over temperature</b>
<b>27</b>	The temperature of the external discharge resistor is monitored by the temperature accumulators. When the resistor temperature (Pr 11.65) reaches 100 % the drive will trip See Pr 11.62, Pr 11.63 and Pr 11.64

Trip	Diagnosis
<b>O.Ld1</b>	<b>Digital output overload: total current drawn from 24 V supply and digital outputs exceeds 200 mA</b>
26	Check total load on digital outputs (terminals 24, 25 and 26) and the +24 V rail (terminal 22)
<b>O.SPd</b>	<b>Motor speed has exceeded the over speed threshold</b>
7	The drive will trip O.SPd if the armature is open circuit when the drive is in estimated speed mode. Check armature circuit If the speed feedback (Pr <b>3.02 (di05, 0.40)</b> ) exceeds the over speed threshold (Pr <b>3.08</b> ) in either direction an over speed trip is produced. If this parameter is set to zero, the over speed threshold is automatically set to 1.2 x Pr <b>1.06 (SE02, 0.23)</b> or Pr <b>1.07 (SE01, 0.22)</b> . Reduce the speed loop gain (Pr <b>3.10 (SP01, 0.61)</b> ) and speed integral (Pr <b>3.11 (SP02, 0.62)</b> ) to prevent speed overshoot.
<b>PAd</b>	<b>Keypad has been removed when the drive is receiving the speed reference from the keypad</b>
34	Install keypad and reset Change speed reference selector to select speed reference from another source
<b>PLL Err</b>	<b>Phase Lock Loop cannot lock to the auxiliary supply</b>
174	Check auxiliary supply is stable
<b>PS</b>	<b>Internal power supply fault</b>
5	Remove any Solutions Modules and reset Hardware fault - return drive to supplier
<b>PS.10V</b>	<b>10 V user power supply current greater than 10 mA</b>
8	Check wiring to terminal 4 Reduce load on terminal 4
<b>PS.24V</b>	<b>24 V internal power supply overload</b>
9	The total user load of the drive and Solutions Modules has exceeded the internal 24 V power supply limit. The user load consists of the drive's digital outputs, the SM-I/O Plus digital outputs, the drive's main encoder supply and the SM-Universal Encoder Plus encoder supply. <ul style="list-style-type: none"> <li>Reduce load and reset</li> <li>Provide an external 24 V &gt;50 W power supply</li> <li>Remove any Solutions Modules and reset</li> </ul>
<b>PSAVE.Er</b>	<b>Power down save parameters in the EEPROM are corrupt</b>
37	Indicates that the power was removed when power down save parameters were being saved. The drive will revert back to the power down parameter set that was last saved successfully. Perform a user save (Pr <b>xx.00</b> to SAVE and reset the drive) or power down the drive normally to ensure this trip does or occur the next time the drive is powered up.
<b>SAVE.Er</b>	<b>User save parameters in the EEPROM are corrupt</b>
36	Indicates that the power was removed when user parameters were being saved. The drive will revert back to the user parameter set that was last saved successfully. Perform a user save (Pr <b>xx.00</b> to SAVE and reset the drive) to ensure this trip does or occur the next time the drive is powered up.
<b>SCL</b>	<b>Drive RS485 serial comms loss to remote keypad</b>
30	Reinstall the cable between the drive and keypad Check cable for damage Replace cable Replace keypad
<b>SL</b>	<b>AC input phase loss</b>
170	Ensure all three thyristor bridge supply phases are present Check input voltage levels are correct (at full load) The fault can occur due to lack of synchronisation between line supply and electronic supply. If voltage is proven to be present on L1 L2 L3 and E1 E3 and Pr <b>5.05</b> reads incorrectly for example 0 then check for phase shift between the two supplies.
<b>SLAVE.Er</b>	<b>Slave tripped in parallel system</b>
156	This trip could occur if the received master comms is lost or the slave OK bits are lost, please check that the correct type of RJ45 cable is used between the master and slave drives. The paralleling cable should be CAT5E screened none cross over RJ45 to RJ45 cable (standard ethernet cable). Please also check the slave OK bits wiring and configuration. For detailed trip conditions please refer to the <i>Mentor MP Advanced User Guide</i> , parameter description for Pr <b>5.43</b> on page 85.
<b>SLX.dF</b>	<b>Solutions Module slot X trip: Solutions Module type installed in slot X changed</b>
204,209,214	Save parameters and reset
<b>SLX.Er</b>	<b>Solutions Module slot X trip: Solutions Module in slot X has detected a fault</b>
202,207,212	<b>Feedback module category</b> See the <i>Diagnostics</i> section in the relevant Solutions Module User Guide for more information.

Trip	Diagnosis
<b>SLX.HF</b>	<b>Solutions Module slot X trip: Solutions Module X hardware fault</b>
200,205,210	Ensure Solutions Module is installed correctly Return Solutions Module to supplier
<b>SLX.nF</b>	<b>Solutions Module slot X trip: Solutions Module has been removed</b>
203,208,213	Ensure Solutions Module is installed correctly Reinstall Solutions Module Save parameters and reset drive
<b>SL.rtd</b>	<b>Solutions Module trip: Drive mode has changed and Solutions Module parameter routing is now incorrect</b>
215	Press reset. If the trip persists, contact the supplier of the drive.
<b>SLX.tO</b>	<b>Solutions Module slot X trip: Solutions Module watchdog timeout</b>
201,206,211	Press reset. If the trip persists, contact the supplier of the drive.
<b>S.Old</b>	<b>The maximum power the over voltage suppressor can handle has been exceeded</b>
171	Check the recommended line reactors are installed Check the recommended external suppressor resistor is installed
<b>S.OV</b>	<b>Excessive suppressor voltage</b>
172	Operation of the drive requires the installation of the external suppressor resistance, see section 4.7 <i>External suppressor resistor</i> on page 50.
<b>t002</b>	<b>Reserved</b>
2	A value of 2 is being written to user trip (Pr <b>10.38</b> ). The drives internal logic, on board or Solutions Module program must be interrogated. The program should be modified so that only trips defined as User trip are used.
<b>t004</b>	<b>Reserved</b>
4	See diagnosis for t002
<b>t010</b>	<b>Reserved</b>
10	See diagnosis for t002
<b>t019</b>	<b>Reserved</b>
19	See diagnosis for t002
<b>t023</b>	<b>User trip</b>
23	This trip is user defined. The drives internal logic, on board or Solutions module program must be interrogated to find the cause of this trip. A value of 23 is being written to user trip (Pr <b>10.38</b> )
<b>t032</b>	<b>Reserved</b>
32	See diagnosis for t002
<b>t032 to t033</b>	<b>Reserved</b>
32 to 33	See diagnosis for t002
<b>t038 to t039</b>	<b>Reserved</b>
38 to 39	See diagnosis for t002
<b>t040 to t089</b>	<b>User trip</b>
40 to 89	See diagnosis for t023
<b>t099</b>	<b>User trip defined in 2<sup>nd</sup> processor Solutions Module code</b>
99	This solutions module program must be interrogated to find the cause of this trip. A value of 99 is being written to user trip (Pr <b>10.38</b> )
<b>t101</b>	<b>User trip</b>
101	See diagnosis for t023
<b>t102 to t111</b>	<b>Reserved</b>
102 to 111	See diagnosis for t002
<b>t112 to t156</b>	<b>User trip</b>
112 to 156	See diagnosis for t023
<b>t161 to t167</b>	<b>Reserved</b>
161 to 167	See diagnosis for t002
<b>t176</b>	<b>Reserved</b>
176	See diagnosis for t002

Trip	Diagnosis
<b>t192 to t196</b>	<b>Reserved</b>
<b>192 to 196</b>	See diagnosis for t002
<b>t216</b>	<b>User trip</b>
<b>216</b>	See diagnosis for t023
<b>th</b>	<b>Motor thermistor trip</b>
<b>24</b>	Check motor temperature Check thermistor continuity. Set Pr <b>7.15 (in01, 0.81)</b> = VOLt and reset the drive to disable this function
<b>th.Err</b>	<b>Missing thyristor</b>
<b>173</b>	Hardware fault - return drive to supplier
<b>thS</b>	<b>Motor thermistor short circuit</b>
<b>25</b>	Check motor thermistor wiring Replace motor / motor thermistor Set Pr <b>7.15 (in01, 0.81)</b> = VOLt and reset the drive to disable this function
<b>tunE</b>	<b>Autotune stopped before completion</b>
<b>18</b>	The drive has tripped out during the autotune The red stop key has been pressed during the autotune
<b>tunE1*</b>	<b>The position feedback did not change or required speed could not be reached during the inertia test (see Pr 5.12 (SE13, 0.34))</b>
<b>11</b>	Ensure the motor is free to turn i.e. brake was released Ensure Pr <b>3.26</b> and Pr <b>3.38</b> are set correctly. Check feedback device wiring is correct. Check feedback device coupling to motor
<b>tunE2*</b>	<b>Position feedback direction incorrect or motor could not be stopped during the inertia test (See Pr 5.12 (SE13, 0.34))</b>
<b>12</b>	Check motor cable wiring is correct Check feedback device wiring is correct
<b>tunE3*</b>	<b>Field flux has not decayed to zero during autotune</b>
<b>13</b>	Contact the supplier of the drive
<b>tunE4*</b>	<b>Back emf detected during autotune</b>
<b>14</b>	Check that the motor is not spinning when a static autotune is carried out
<b>tunE5*</b>	<b>No field current detected during autotune</b>
<b>15</b>	Reset Pr <b>5.70 (SE10, 0.31)</b> to nameplate value and re-autotune motor
<b>tunE6*</b>	<b>Cannot achieve ¼ rated back emf during autotune</b>
<b>16</b>	Reset Pr <b>5.70 (SE10, 0.31)</b> to nameplate value and re-autotune motor
<b>tunE7*</b>	<b>Rotating autotune initiated with Estimated speed selected</b>
<b>17</b>	Connect a feedback device to carry out a rotating autotune
<b>UP ACC</b>	<b>Onboard PLC program: cannot access Onboard PLC program file on drive</b>
<b>98</b>	Disable drive - write access is not allowed when the drive is enabled Another source is already accessing Onboard PLC program - retry once other action is complete
<b>UP div0</b>	<b>Onboard PLC program attempted divide by zero</b>
<b>90</b>	Check program
<b>UP OFL</b>	<b>Onboard PLC program variables and function block calls using more than the allowed RAM space (stack overflow)</b>
<b>95</b>	Check program
<b>UP ovr</b>	<b>Onboard PLC program attempted out of range parameter write</b>
<b>94</b>	Check program
<b>UP PAr</b>	<b>Onboard PLC program attempted access to a non-existent parameter</b>
<b>91</b>	Check program
<b>UP ro</b>	<b>Onboard PLC program attempted write to a read-only parameter</b>
<b>92</b>	Check program
<b>UP So</b>	<b>Onboard PLC program attempted read of a write-only parameter</b>
<b>93</b>	Check program
<b>UP udF</b>	<b>Onboard PLC program un-defined trip</b>
<b>97</b>	Check program

Trip	Diagnosis
<b>UP uSEr</b>	<b>Onboard PLC program requested a trip</b>
<b>96</b>	Check program
<b>UV</b>	<b>The drive is running from the external 24 V supply</b>
<b>1</b>	The drive is running from the external 24 V supply

\*If a tunE through tunE 7 trip occurs, then after the drive is reset the drive cannot be made to run unless it is disabled via the drive enable parameter (Pr 6.15) or the control word (Pr 6.42).

**Table 13-2 Serial communications look-up table**

No.	String	No.	String	No.	String
1	UV	92	UP ro	189	EnC1
2	t002	93	UP So	190	EnC2
3	AOC	94	UP ovr	191	EnC3
4	t004	95	UP OFL	192-196	t192 - t196
5	PS	96	UP uSEr	197	EnC9
6	Et	97	UP udf	198	EnC10
7	O.SPd	98	UP ACC	199	dEst
8	PS.10V	99	t099	200	SL1.HF
9	PS.24V	100		201	SL1.tO
10	t010	101	t101	202	SL1.Er
11	tunE1	102-111	t102 - t111	203	SL1.nF
12	tunE2	112-155	t112 - t155	204	SL1.dF
13	tunE3	156	SLAVE.Er	205	SL2.HF
14	tunE4	157	F.OVL	206	SL2.tO
15	tunE5	158	AOP	207	SL2.Er
16	tunE6	159	FbL	208	SL2.nF
17	tunE7	160	Fbr	209	SL2.dF
18	tunE	161	AtL Err	210	SL3.HF
19	t019	162-167	t162 - t167	211	SL3.tO
20	It.AC	168	FdL	212	SL3.Er
21	O.ht1	169	FOC	213	SL3.nF
22	O.ht2	170	SL	214	SL3.dF
23	t023	171	S.Old	215	SL.rtd
24	th	172	S.OV	216	t216
25	thS	173	th.Err	217-229	HF17 – HF29
26	O.Ld1	174	PLL Err		
27	O.ht3	175	C.Prod		
28	cL2	176	t176		
29	cL3	177	C.Boot		
30	SCL	178	C.BUSy		
31	EEF	179	C.Chg		
32-33	t032 - t033	180	C.Optn		
34	Pad	181	C.RdO		
35	CL.bit	182	C.Err		
36	SAVE.Er	183	C.dat		
37	PSAVE.Er	184	C.FULL		
38-39	t038 - t039	185	C.Acc		
40-89	t040 - t089	186	C.rtg		
90	UP div0	187	C.Typ		
91	UP Par	188	C.cpr		



## 13.2 Trip categories

Trips can be grouped into the following categories. It should be noted that a trip can only occur when the drive is not tripped or is already tripped but with a trip with a lower priority number.

**Table 13-3 Trip categories**

Priority	Category	Trips	Comments
1	Hardware faults	HF01 to HF16	These indicate fatal problems and cannot be reset. The drive is inactive after one of these trips and the display shows HFxx.
2	Non-resetable trips	HF17 to HF29, SL1.HF, SL2.HF, SL3.HF	Cannot be reset
3	EEF trip	EEF	Cannot be reset unless a code to load defaults is first entered in parameter x.00
4	SMARTCARD trips	C.Boot, C.Busy, C.Chg, C.Optn, C.RdO, C.Err, C.dat, C.FULL, C.Acc, C.rtg, C.Typ, C.cpr,	SMARTCARD trips have priority 5 during power up.
4	Encoder power supply trips	Enc1, Enc2	These trips can only override the following priority 5 trips: Enc2, Enc9 or Enc10
5	Normal trips	All other trips not included in this table	Can be reset after 1.0 s
6	Self resetting trips	UV	Under voltage trip cannot be reset by the user, but is automatically reset by the drive when the supply voltage is with specification.

Unless otherwise stated, trips cannot be reset until 1.0 s after the trip has been accepted by the drive.

## 13.3 Alarm indications

In any mode an alarm flashes alternately with the data displayed on the 2nd row when one of the following conditions occur. If action is not taken to eliminate any alarm except "Autotune", and "PLC" the drive may eventually trip. Alarms flash once every 640 ms except "PLC" which flashes once every 10 s. Alarms are not displayed when a parameter is being edited.

**Table 13-4 Alarm indications**

Lower display	Description
<b>Hot</b>	Heatsink alarm is active The temperature displayed in Pr 7.04 has exceeded the alarm level (see Pr 7.04).
<b>OVLd</b>	Motor overload The motor I <sup>2</sup> t accumulator (Pr 4.19) in the drive has reached 75 % of the value at which the drive will be tripped and the load on the drive is > motor rated current (Pr 5.07 (SE07, 0.28)).
<b>Autotune</b>	Autotune in progress The autotune procedure has been initialised. 'Auto' and 'tunE' will flash alternately on the display.
<b>CLt</b>	Current limit is active Indicates that current limits are active.
<b>PLC</b>	Onboard PLC program is running An Onboard PLC program is installed and running. The lower display will flash 'PLC' once every 10s.
<b>S.OV</b>	Indicated suppressor over voltage Indicates that the over voltage suppressor voltage is within 30 V of the trip level
<b>S.rS</b>	Suppressor resistor overload Indicates that the external voltage suppressor resistor is in an overload condition
<b>Est SPd</b>	Estimated speed selected The drive has lost speed feedback and automatically selected Estimated speed mode. See Pr 3.55 (Select estimated speed on feedback loss).

## 13.4 Status indications

**Table 13-5 Status indications**

Upper display	Description	Drive output stage
<b>dEC</b>	Decelerating Speed is ramping to zero after a stop	Enabled
<b>inh</b>	Inhibited Enable input is inactive	Disabled
<b>POS</b>	Position Position control active during orientation stop	Enabled
<b>rdY</b>	Ready Enable closed, but drive not active	Disabled
<b>run</b>	Running Drive active and motor running	Enabled
<b>StoP</b>	Stopped Drive active, but holding zero speed.	Enabled
<b>triP</b>	Tripped Drive is tripped.	Disabled

## 13.5 Displaying the trip history

The drive retains the last 10 trips that have occurred.

Table 13-6 shows parameters used to store the last 10 trip.

**Table 13-6 Trips**

Menu 0	Parameter	Description	Display
0.51	10.20	Trip 0 (most recent trip)	tr01
0.52	10.21	Trip 1	tr02
0.53	10.22	Trip 2	tr03
0.54	10.23	Trip 3	tr04
0.55	10.24	Trip 4	tr05
0.56	10.25	Trip 5	tr06
0.57	10.26	Trip 6	tr07
0.58	10.27	Trip 7	tr08
0.59	10.28	Trip 8	tr09
0.60	10.29	Trip 9	tr10

## 13.6 Behaviour of the drive when tripped

If the drive trips the output of the drive is disabled so that the drive stops controlling the motor. If any trip occurs (except UV) the following read only parameters are frozen to help in diagnosing the cause of the trip

**Table 13-7 Parameters frozen on trip**

Menu 0	Parameter	Description	Display
0.36	1.01	Speed reference selected	di01
	1.02	Pre-skip filter reference	
0.37	1.03	Pre-ramp reference	di02
0.38	2.01	Post ramp reference	di03
0.39	3.01	Final speed reference	di04
0.40	3.02	Speed feedback	di05
	3.03	Speed error	
0.41	3.04	Speed controller output	di06
0.43	4.01	Current magnitude	di08
	5.01	Armature firing angle	
0.45	5.02	Armature voltage	di10
	5.03	Output power	
	5.04	Estimated speed	
	5.05	Line voltage	
	5.58	Field firing angle	
0.82	7.01	Analog input 1	in02
0.83	7.02	Analog input 2	in03
0.84	7.03	Analog input 3	in04
	10.77	Input frequency	

### Analog and digital I/O

The analog and digital I/O on the drive continue to work correctly if a trip occurs, except the digital outputs will go low if one of the following trips occur: O.Ld1, PS.24V.

### Drive logic functions

The drive logic functions (i.e. PID, variable selectors, threshold detectors, etc.) continue to operate when the drive is tripped.

### Onboard PLC program

The Onboard PLC program continues to run if the drive is tripped, except if one of Onboard PLC program trips occur.

## 13.7 Trip masking

Drive trips can be masked by setting the appropriate trip code in Pr 10.52 to Pr 10.61. Refer to Pr 10.52 to Pr 10.72 (Advanced parameter descriptions chapter - Menu 10) in the *Mentor MP Advanced User Guide* for further information.

## 14 UL information

Mentor MP drives up to 575 V have been assessed to comply with both ULus and cUL requirements.

Control Techniques UL file number is E171230. Confirmation of UL listing can be found at website: [www.ul.com](http://www.ul.com)

### 14.1 Common UL Information

Conformity: The drive conforms to UL listing requirements only when the following are observed:

1. The drive is installed in a type 1 enclosure, or better as defined in UL 50.
2. The surrounding air temperature does not exceed 40 °C when the drive is operating.
3. The terminal torques specified in section 3.9.3 *Torque settings* on page 33 are to be used.
4. The power terminal lug used to crimp the, I/P & O/P cables are to be UL listed.
5. The drive is to be installed in to a pollution degree 2 environment.
6. If the drive control stage is supplied by an external power supply, (+24 V), the external power supply must be a UL class 2 power supply.
7. Fuses sized as specified in the various tables in section 4.6 *Cable and fuse size ratings* on page 42 are to be used.
8. Field wiring is to be class 1 75 °C (167 °F) copper wire only.

### Motor overload protection

All models incorporate an internal overload protection model for the motor load that does not require the use of an external or remote overload protection device.

The protection level is adjustable, and the method of adjustment is provided with the instructions for the product.

Maximum current overload is dependant on the values entered into the current limit parameters (motoring current limit, regen current limit and symmetrical current limit entered as percentage) and the motor rated current parameter (entered in amperes).

The duration of the overload is dependant on motor thermal time constant (variable up to a maximum of 3000 seconds). The default overload protection is set such that the product is capable of 150 % of the current value entered into the motor rated current parameter (Pr 5.07 (SE07, 0.28)) for 30 seconds (20 seconds for MP470A4(R), MP470A5(R), MP825A5(R) and MP825A6(R)). The product also provides user terminal default functionality such that the product can be connected to a motor thermistor to protect the motor in terms of temperature, in the event of a motor cooling fan failure.

### Over speed protection

The drive provides overspeed protection. However it does not provide the level of protection afforded by an independent high integrity overspeed protection device.

### 14.2 AC supply specification

The maximum UL supply voltage is 600 Vac.

The drive is suitable for use in a circuit capable of delivering not more than 100,000 rms symmetrical Amperes at 575 V (size 1A and 1B).

### 14.3 Maximum ratings

The drive models are listed as having the maximum current rating (FLC) shown in Table 2-2 and Table 2-3 in section 2.2 *Current ratings* on page 8.

### 14.4 Parallel operation

The drives are not currently UL listed for parallel operation.

## 14.5 Safety label

The safety label supplied with connectors and mounting brackets must be placed on a fixed part of the drive enclosure where it can be seen clearly by maintenance personnel for UL compliance.

The label clearly states "CAUTION risk of electric shock power down at least 10 minutes before removing cover".

## 14.6 UL Listed accessories

- SM-Keypad
- SM-DeviceNet
- SM-INTERBUS
- SM-Ethernet
- SM-Applications Plus
- SM-Encoder Plus
- SM-I/O Plus
- SM-I/O Lite
- SM-I/O PELV
- SM-I/O 24V Protected
- Single ended encoder interface
- MP-Keypad
- SM-PROFIBUS-DP-V1
- SM-CANopen
- SM-EtherCAT
- SM-Applications Lite-V2
- SM-Universal Encoder Plus
- SM-Encoder Output Plus
- SM-I/O 32
- SM-I/O Timer
- SM-I/O 120V
- 15-way D-type converter

# Contents

## Symbols

+10V user output .....	57
+24V external input .....	57
+24V user output .....	58

## Numerics

0V common .....	57
4 -20mA .....	77

## A

Acceleration .....	72, 80, 82, 108
Accuracy .....	109, 155
Acoustic noise .....	156
Air-flow in a ventilated enclosure .....	30
Altitude .....	155
Analog I/O .....	123
Analog input 2 .....	58
Analog input 3 .....	58
Analog output 1 .....	58
Analog output 2 .....	58
Analog reference resolution .....	109

## B

Binary sum .....	129
Brake control function .....	134

## C

Cautions .....	6
Cooling fan air flow .....	156
Cooling method .....	155
Current control .....	112

## D

Deceleration .....	80, 82, 108, 149
Destination parameter .....	56
Digital I/O .....	125
Digital I/O 1 .....	59, 60
Digital I/O 2 .....	59, 60
Digital I/O 3 .....	59, 60
Digital Input 1 .....	59
Digital Input 2 .....	59
Digital Input 3 .....	59
Digital reference resolution .....	109
Dimensions (overall) .....	156
Display .....	62
Drive enable .....	59

## E

Encoder lines per revolution .....	77
Encoder supply voltage .....	77
Encoder type .....	77
Encoder types .....	61

## F

Field control .....	116
---------------------	-----

## H

Humidity .....	155
----------------	-----

## I

IP Rating (Ingress protection) .....	155
Items supplied with the drive .....	14

## M

Menu 01 - Speed reference .....	102
Menu 02 - Ramps .....	106
Menu 03 - Speed feedback, speed control .....	109
Menu 04 - Torque and current control .....	112
Menu 05 - Motor and field control .....	116
Menu 06 - Sequencer and clock .....	121
Menu 07 - Analog I/O .....	123
Menu 08 - Digital I/O .....	125
Menu 09 - Programmable logic, motorized pot and binary sum .....	129
Menu 10 - Status and trips .....	132
Menu 11 - General drive set-up .....	133
Menu 12 - Threshold detectors, variable selectors and brake control function .....	134
Menu 13 - Position control .....	140
Menu 14 - User PID controller .....	144
Menu 15, 16 and 17 - Solutions Module slots .....	147
Menu 18 - Application menu 1 .....	148
Menu 19 - Application menu 2 .....	148
Menu 20 - Application menu 3 .....	148
Menu 21 - Second motor parameters .....	149
Menu 22 - Additional Menu 0 set-up .....	149
Menu 23 - Header selections .....	149
Minimum reference clamp .....	72
Mode parameter .....	56
Motor control .....	116
Motorized pot .....	129

## N

Notes .....	6
-------------	---

## O

Output frequency .....	155
------------------------	-----

## P

Parameter ranges .....	99
Parameter x.00 .....	71
PID controller .....	144
Position control .....	140
Precision reference Analog input 1 .....	57
Programmable logic .....	129

## R

Ramps .....	106
Reference modes .....	149
Relay contacts .....	59
Resolution .....	109

## S

Safety Information .....	6
Second motor parameters .....	149
Sequencer .....	121
Serial comms lead .....	54
Serial communications port isolation .....	54
Solutions Module ID codes .....	147
Solutions Module slots .....	147
Speed control .....	109
Speed feedback .....	109
Speed range .....	155
Speed reference .....	102
Start up time .....	155
Status .....	189
Status Indications .....	189
Surge immunity of control circuits - long cables and connections outside a building .....	53
Surge suppression for analog and bipolar inputs and outputs	54
Surge suppression for digital and unipolar inputs and outputs	54

## T

Temperature .....	155
Terminal sizes .....	31
Thermistor .....	77
Threshold detectors .....	134
Torque control .....	112
Torque settings .....	33
Trip .....	181
Trip Indications .....	181

## V

Variable maximums .....	99
Variable selectors .....	134
Vibration .....	155

## W

Warnings .....	6
----------------	---

# 驱动世界发展.....



**Control Techniques** A leader in intelligent drives, drive systems & Solar PV energy

尼得科 **Control Techniques** (简称**尼得科CT**)

2017年3月, **Control Techniques** 加入尼得科集团, **Control Techniques** 以其40多年来驱动技术领域专业经验, 为客户提供高性能, 高可靠性的能效型产品。其先进的数据技术包括交、直流驱动器和伺服电机与控制器。我们致力于工业自动化发展, 从英国总部的产品开发, 到全球45个自动化中心, 能够为您提供全方位行业解决方案。

**Control Techniques** 一直是驱动器领域的专家和运动控制技术的全球领导者。

在中国, 我们(上海绿创)是尼得科 **Control Techniques** 一级代理商和维修中心。为客户提供专业, 全面, 快速的驱动解决方案与最优质的售后技术维修等整体服务。

## 关于尼得科CT上海绿创

上海绿创自动化设备有限公司(原上海盛控)是一家高科技民营企业, 位于上海闵行区莘庄镇。

本公司为尼得科CT(**Control Techniques**)一级代理商&维修服务中心

ABB葆德一级代理商及全国技术服务中心 & 安川变频伺服全国重点分销中心

专业提供变频器维修, 直流调速器维修, 伺服驱动器维修, 伺服电机维修及相关技术服务等

如需了解详情, 请你浏览网站: <http://www.ams-ct.com>; 联系电话: 021-51093390



为了快速的获得服务与支持, 您可以通过以下方式联系我们:

总机: +86-021-51093390 直线: +86-021-34172694

传真: +86-021-51093390\*8016 021-64785447

地址: 上海市闵行区园文路28号金源中心1019室

网址: <http://www.shlc-ct.com>

邮箱: [shlc@shlc-ct.com](mailto:shlc@shlc-ct.com)

24 x 365小时全天候为用户电话支持、受理商务及技术咨询。

全国免费客服热线: **400-021-5108**



轻松一扫, 即刻体验!

本手册中的信息仅作参考之用, 不具有任何合同性质。由于艾默生驱动与电机在不断对自己的产品进行发展完善, 因此不确保本手册信息的准确性。此外, 艾默生驱动与电机保留随时修改产品的权利, 修改详情恕不另行通知。