

# Mobrey

## Vertical magnetic level switches

Data sheet  
IP107

- Weatherproof
- Flameproof
- Direct mount
- Chamber mount
- Displacer controls

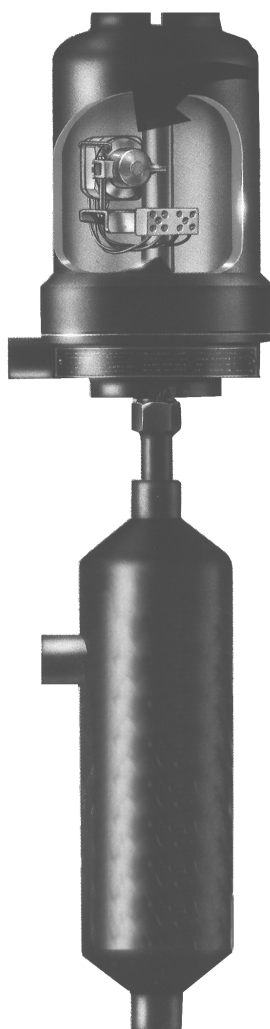

### Operation

The float carries a stainless steel sheathed permanent magnet which rises and falls in the glandless pressure tube with changing liquid level.

A switch mechanism is mounted inside the enclosure adjacent to the pressure tube.

Switching is achieved with the unique Mobrey 'three-magnet' system, giving snap-action 'latch-on' switching.

Vertical movement of the float magnet in the pressure tube simultaneously actuates the secondary and tertiary magnets in the switch mechanism to operate the contacts. This 'three-magnet' system enables the float magnet to pass on and actuate switch mechanisms at other levels. Switch mechanisms already actuated cannot re-set until the return of the primary magnet actuates the magnet system once again.

- Unique 3 magnet latching switch mechanism
- No springs in switch mechanism

## Contents

	<i>Page</i>
Introduction	3
Switch Mechanisms	4
1. Direct mount displacer controls	5-7
2. Direct mount float switches	8-9
3. Chamber mounted controls	
3.1 Carbon steel chambers	10-11
3.2 316L stainless steel chambers	12-13
4. Dimensional and operating level data	14
5. Technical data and options	15
6. Applications and users	16



Whether you require a switch for critical area applications or just general purpose control, the extensive range of Mobrey chambers ensures that we will always have a solution to your particular problem.

A choice of carbon steel chambers is available, or for more rigorous applications we supply a series of 316 stainless steel chambers. A variety of tank and process connections are available to make installation simple and economic. This gives you the choice to meet your application in keeping with your budget.

## Introduction

Whether you require a switch for critical area applications or just general purpose control, the extensive range of Mobrey chambers ensures that we will always have a solution to your particular problem.

A choice of carbon steel chambers is available, or for more vigorous applications we supply a series of 316 stainless steel chambers. A variety of tank and process connections is available to make installation simple and economic. This gives you the choice to meet your application in keeping with your budget.

Mobrey vertical magnetic level switches for industrial and process control use have been available for over 20 years and have been steadily gaining a reputation for quality and reliability.

Based on the industry standard boiler water level controls these controls employ the same three magnet switch mechanism for snap-action latching switching.

The design of this unique switch mechanism overcomes all the inherent problems of mercury tubes and micro switches. Even under severe vibration conditions there are no springs to cause contact bounce, hover, or even failure. The snap action magnets give positive stable latching time after time after time.

There are two switching functions available : 2 x SPST (SPCO) switching or DPDT (DPCO) switching, and each comes in four variants :-

- General purpose use with silver cadmium oxide contacts for long life.
- Low power circuit used with gold plated contacts for use in low current/voltage applications such as I.S. circuits.
- High power circuits giving up to 10A switching capability.
- Hermetically sealed for the ultimate in reliability - sealed for life.

When controls are required to operate in extreme conditions, the unique Mobrey hermetically sealed switch provides dependable life long operation that you can rely on. With **all** its moving parts and contacts completely enclosed, this genuine

hermetically sealed switch is suitable for use in corrosive atmospheres and low temperature environments.

### Features

- Unique switching mechanism
  - totally reliable
- No springs in switch mechanism
  - positive snap action switching
- Vibration resistant
  - eliminates spurious trips
- Multi-switching models
  - cost effective control
- Genuine hermetically sealed switch option - totally safe and secure
- Material certification to DIN 50049 3.1B
- Materials to ASTM and B.S. Standards

### Approvals

Mobrey vertical controls are certified E Exd IIC T6 in accordance with BS5501 Part 5 (en50018).

BASEEFA certificate no. 90C1262

Flameproof models are available constructed in either aluminium alloy to keep weight to a minimum or cast iron for extended usage in arduous environments. Users must comply with installation details given in leaflet IP153.

### Intrinsically Safe Use

For use in intrinsically safe circuits, gold plated switch contacts are recommended (see page 4). Users are reminded that it is their responsibility to obtain the necessary system approval and licences for such circuits.

### BS5750 : Part 1

Solartron Mobrey Ltd has been assessed and approved by Lloyds

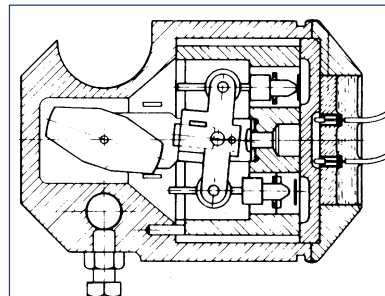

**Section through type H4 switch mechanism**



**Hermetically sealed switch mechanism**

Register Quality Assurance Ltd against BS5750 : Part 1: 1987 and ISO 9001 - 1987 EN 29001 - 1987 for the design, development and manufacture of electrical, mechanical and ultrasonic level measuring equipment.

### Quality Assurance

With over 20 years worldwide experience in the major power, nuclear and petro-chemical industries, Solartron Mobrey is able to accommodate testing, surveying and documentation requirements as specified at the time of order. Inspection by customers or nominated inspection agencies can be arranged.

## KDG Mobrey Switch Mechanisms

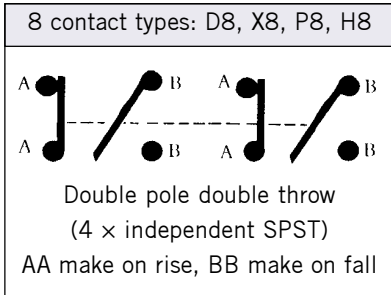
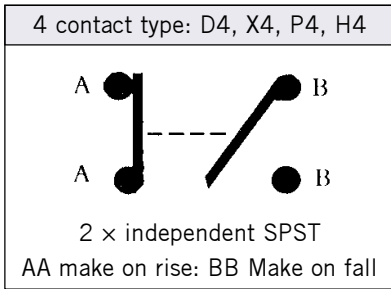

**Note:** For DPDT operation, installer must common any one pair of A and B wires in the terminal block for each of the two ends of the switch mechanism.

### Switch Enclosures

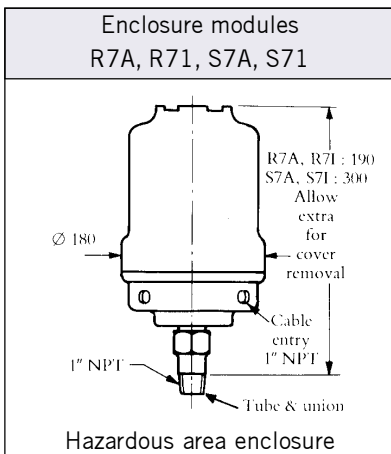
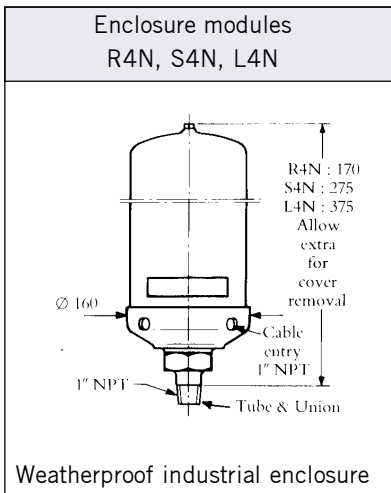

**Type D4, D8:** General purpose switch mechanism.

**Type X4, X8:** High current switch mechanism.

**Type P4, P8:** Switch mechanism with gold plated contacts for use in low power or intrinsically safe circuits.

**Type H4, H8:** Hermetically sealed mechanism with all moving parts and contacts enclosed in an inert gas filled stainless steel enclosure. Suitable for use in low temperatures, contaminated atmospheres and intrinsically safe circuits.

### Electrical Rating

Type	Temp wetside °C	Low temp use	AC max. values			DC max. values			
			VA	Volts	Amps	Watts	Volts	Res amps	Ind amps
<b>D4, D8</b>	400	No	2000	440	5	50	250	5	0.5
<b>X4, X8</b>	250	No	2000	440	10	50	250	10	0.5
<b>P4, P8</b>	400	No	6	250	0.25	3.6	250	0.25	0.1
<b>H4, H8</b>	250	-50°C	2000	440	10	50	250	10	0.5

Each switch mechanism has flying leads which are factory wired to ceramic terminal blocks fixed in the switch enclosure.

### Warning

Gold plating on the contacts of P4 and P8 switch mechanisms may be permanently damaged if the mechanisms are used to switch circuits with values greater than those shown above.

Switches must not be used for the direct starting of motors. Contacts should be wired in series with the operating coils of relays, contactor starters or solenoid valves and fused separately.

### Weatherproof IEC144: IP66.

Aluminium alloy based/drawn steel cover.

Type R4N: Fixed switch

Type S4N: 100mm switch adjustment

Type L4N: 200mm switch adjustment

### Flameproof EExdIICT6 (Weatherproof IP66)

Aluminium alloy base and cover "A"

Cast iron base and cover "I"

Type R7A/R71: Fixed switch

Type S7A/S71: 100mm switch adjustment

### Conduit entries

Enclosures supplied with four contact switch mechanisms have a single 1" NPT conduit entry.

Enclosures supplied with eight contact switch mechanisms have 2 x 1" NPT conduit entries.

Users must comply with the approval requirements for connection as detailed in Installation Leaflet IP153.

**Tube and Unions:** 316 stainless steel throughout. Welded construction with additional swaging technique to ensure maximum integrity. Individually pressure tested to 150 bar (operating pressure will be limited by float or flange specified).

**Paint Finish:** Black stove paint. Epoxy paint finishes available on request.

## 1.0 Direct Mount Displacer Conti

Mobrey displacer operated controls are ideal for sump application and other top mounting duties such as low level alarm in deep tanks. Their principle of operation also makes them suitable, in a modified form, for very high pressure or low S.G. applications.

The four most popular displacer arrangements are shown in this schematic diagram, which covers most of the likely applications. However, should you have a different requirement, we would be pleased to quote a model for your particular application.

### Principle of Operation

The displacer element, made of either 316 stainless steel or ceramic depending upon duty, is suspended on a stainless steel cable from a spring. The element is always heavier than its equivalent volume of the liquid in which it is to operate, and so will extend the tension spring at all times. In free air, the spring will be extended to a known length, controlled by a mechanical stop to prevent oversteering. Fixed to the spring is the float rod and magnet assembly, free to move up and down as the spring extends or contracts, and outside the pressure tube in the usual manner is the switch mechanism.

As liquid rises to cover the displacer element, a buoyancy force is created equal to the weight of the liquid displaced. This force in effect is seen by the spring as a reduction in weight, causing the spring to

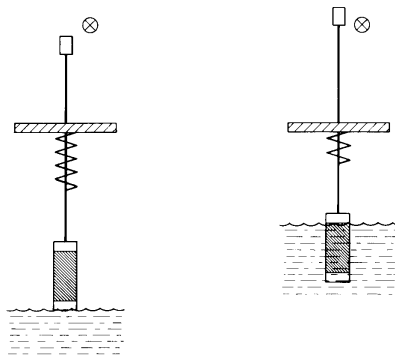

Fig v

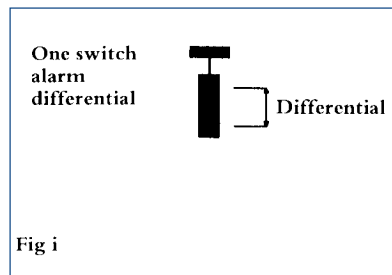

Fig i

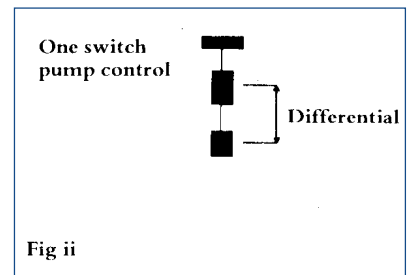

Fig ii

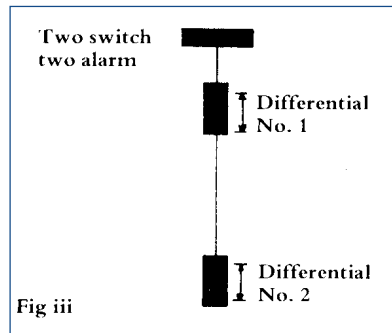

Fig iii

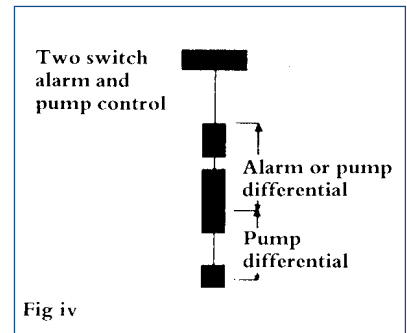

Fig iv

contract, hence moving the magnet upwards inside the pressure tube and actuating the switch mechanism. On a falling liquid level, the displacer element is uncovered and the spring sees an increasing effective weight, causing the spring to extend and move the magnet to re-set the switch mechanism (Fig i and v).

This simple principle can be refined to operate a single switch over a very wide differential by providing the buoyancy force from two elements instead of just one (Fig ii).

Two switch models are available for either two alarm duty with two narrow differentials (Fig iii) or for pump control/alarm duty with appropriate differentials (Fig iv).

In all cases, because the elements are suspended on a cable, switching or control levels can be several metres below the mounting flange, and are fully field adjustable by re-setting the elements on the cable.



Displacer Control

## Displacer Controls: Ordering Information

<b>Code</b>	<b>Displacer operated alarm and pump control switches</b>									
<b>D</b>	Direct mount: Displacer controls									
<b>Code</b>	<b>Material of mounting flange</b>									
<b>C</b>	Carbon steel. ASTM A105 (For use +300°C to -10°C)									
<b>S</b>	315L stainless steel. ASTM A182: F316L (For use +300°C to -50°C)									
<b>Code</b>	<b>Displacer function and specification</b>									
	<b>Function</b>	<b>Elements</b>	<b>Material of</b>		<b>S.G. Range</b>		<b>Operating</b>	<b>Max. pres.</b>		
			<b>Trim</b>	<b>Spring</b>	<b>4 Contact</b>	<b>8 Contact</b>	<b>temp. range</b>	<b>20°C</b>		
<b>1D</b>	One switch narrow diff.	316 S.S.	316 Stainless Steel	Nimonic 90	0.6 - 1.2	0.75 - 1.2	-50°C to +300°C	102 bar		
<b>2D</b>	One switch wide diff.	316 S.S.			0.5 - 1.2	0.75 - 1.2	-50°C to +300°C			
<b>3D</b>	Two switch 2 wide diff.	316 S.S.			0.6 - 1.2	0.8 - 1.2	-50°C to +300°C			
<b>8D</b>	Two switch 2 normal diff.	315 S.S.			0.6 - 1.2	0.6 - 1.2	-50°C to +300°C			
<b>Code</b>	<b>Switch enclosure</b>									
	<b>Duty</b>	<b>Material of</b>		<b>Material of</b>	<b>Switch</b>	<b>Max. no. of switch</b>				
		<b>Base</b>	<b>Cover</b>	<b>wetted parts</b>	<b>adjustment</b>	<b>mechanisms</b>				
<b>S4N</b>	Weather proof IP66	Aluminium alloy*	Drawn steel	316 stainless steel	Adjust switching point by moving displacer elements on cable	2				
<b>S7A</b>	Flameproof	Aluminium alloy*	Aluminium alloy							
<b>S71</b>	EExdIICT6	Cast iron	Cast iron							
* Base material will be cast iron whenever 8 contact switches are specified										
<b>Code</b>	<b>Number of switch mechanisms</b>									
<b>1</b>	Specify 1 for single switch models 1D, 2D, 4D, 5D									
<b>2</b>	Specify 2 for two switch models 3D, 6D, 8D, 9D									
<b>Code</b>	<b>Type of switch mechanism</b>									
	<b>Switch mechanism duty</b>		<b>Max. wetside temperature</b>	<b>A.C. max. values</b>			<b>D.C. max. values</b>			
				Volts	Amps	VA	Volts	Res. I	Ind. I	Watts
	<b>4 Contact: 2 x SPST</b>									
<b>D4</b>	General purpose		300°C	440	5	2000	250	5	0.5	50
<b>P4</b>	Low power circuits		300°C	250	0.25	6	250	0.25	0.1	3.6
<b>X4</b>	High power circuits		250°C	440	10	2000	250	10	0.5	50
<b>H4</b>	Hermetically sealed		250°C	440	10	2000	250	10	0.5	50
	<b>8 Contact: DPDT</b>									
<b>D8</b>	General purpose		300°C	440	5	2000	250	5	0.5	50
<b>P8</b>	Low power circuits		300°C	250	0.25	6	250	0.25	0.1	3.6
<b>X8</b>	High power circuits		250°C	440	10	2000	250	10	0.5	50
<b>H8</b>	Hermetically sealed		250°C	440	10	2000	250	10	0.5	50
	/									
<b>Code</b>	<b>Mounting arrangement</b>									
<b>0</b>	1" N.P.T. Thread: 316 stainless steel standard							These are our stocked flanges.		
<b>60</b>	3" # 150 R.F. ANSI B16.5/BS1560							Other flange sizes and ratings are available on request.		
<b>61</b>	3" # 300 R.F. ANSI B16.5/BS1560									
<b>62</b>	3" # 600 R.F. ANSI B16.5/BS1560									
<b>65</b>	4" # 150 R.F. ANSI B16.5/BS1560									
<b>66</b>	4" # 300 R.F. ANSI B16.5/BS1560									
<b>67</b>	4" # 600 R.F. ANSI B16.5/BS1560									
<b>D</b>	<b>C</b>	<b>3D</b>	<b>S7A</b>	<b>2</b>	<b>D4</b>	<b>/</b>	<b>60</b>	<b>Typical ordering information</b>		

**Note: Customers must state operating pressure, temperature and specific gravity, together with function of each switch mechanism when ordering.**

Due to component tolerances, dimensions D, DB, E and S given on page 7 are approximate and may vary on each control by up to 10mm. Setting the control to operate at the required level can be achieved on site by adjusting the element up or down on the cable as necessary.

## Displacer types and dimensional details

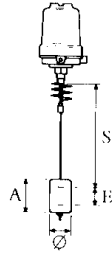

Single switch wide differential: 2D, 5D

The two displacer elements are positioned at any point on the cable to correspond to the switching levels required. When the liquid level drops to the lower displacer the switch is actuated and starts (or stops) a pump; when the liquid rises to the upper displacer the switch is again actuated to stop (or start) the pump.

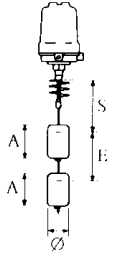

Switch types	D4	P4	X4	H4	D8	P8	X8	H8
S.G.	0.6	0.75	1.0	1.2	0.75	1.0	1.2	
S min	315	335	365	380	275	320	340	
E	90	70	60	55	135	105	90	

2D St. Steel: A = 216      Ø = 60.3

Switch types	D4	P4	X4	H4	D8	P8	X8	H8
S.G.	0.5	0.8	1.0	1.2	0.75	0.8	1.0	1.2
S min	415	430	430	425	390	390	400	400
E min	165	110	95	80	205	200	165	140

S min = Adjustable distance to upper switching level.  
E min = Differential  
D = Minimum dead band

### Two switch 2 narrow differentials: 8D, 9D

The displacers are positioned to form two elements of similar lengths, such that two alarm points may be given. This arrangement is typical of sump application.

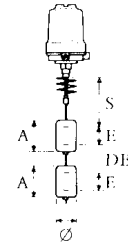

### Two switch 2 wide differentials: 3D, 6D

A pump is controlled between the middle and the lower pump displacers positioned on the cable at the required levels. Should the level rise to the upper displacer this actuates the upper alarm switch which remains actuated until the level drops to the middle displacer.

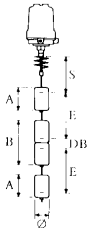

8D St. Steel: A = 216      Ø = 60.3

Switch types	D4	P4	X4	H4	D8	P8	X8	H8
S.G.	0.6	0.8	1.0	1.2	0.8	1.0	1.2	
S min	390	385	375	365	355	350	345	
E min	90	70	60	55	135	105	90	
Dead band	200	230	255	310	165	215	250	

Alternatively, the upper switch could control a second pump.

3D St. Steel: A = 152 B = 304 Ø = 60.3

Switch types	D4	P4	X4	H4	D8	P8	X8	H8
S.G.	0.6	0.8	1.0	1.2	0.8	1.0	1.2	
S min	390	385	375	365	355	350	345	
E min	135	110	95	80	200	145	140	
Dead band	220	255	285	310	165	215	250	

Switch mechanisms		Switch enclosures	
4 Contact: D4 P4 X4 H4	8 Contact: D8 P8 X8 H8	Weatherproof: S4N	Flameproof: S7A S71
<p>2 x independent SPST AA make on rise; BB make on fall</p>	<p>Double pole double throw (4 x independent SPST) AA make on rise; BB make on fall</p>	<p>S4N: 275 Allow extra for cover removal Cable entry 1" NPT 1" NPT Tube &amp; union</p>	<p>S7A, S71: 300 Allow extra for cover removal Cable entry 1" NPT 1" NPT Tube &amp; union</p>

## 2.0 Direct Mounting Float Switches: Ordering Information

Code	Float operated alarm and pump control switches										
D	Direct mount: Float switches										
	<b>Code Material of mounting flange</b>										
C	Carbon steel ASTM A105 (for use + 400°C to -10°C)										
S	316L stainless steel ASTM A182: F316L (for use + 400°C to -100°C)										
	<b>Code Switch Enclosure</b>										
	<b>Minimum S.G.</b>	<b>Pressure rating (bar)</b>			<b>Float diameter</b>	<b>Matching enclosures</b>	<b>Matching mounting flanges</b>				
		<b>20°C</b>	<b>250°C</b>	<b>400°C</b>							
1F	0.80	34.5	22.0	20.0	67	All models	3" NB and larger				
2F	0.75	102.1	83.4	69.0	90		4" NB minimum				
3F	0.65	51.1	41.7	34.5	88						
4F	0.54	19.6	12.1	6.5	88						
	<b>Code Switch Enclosure</b>										
	<b>Duty</b>	<b>Material of base</b>	<b>Material of cover</b>	<b>Material of wetted parts</b>	<b>Switch adjustment</b>	<b>Max. no. of switches</b>					
						<b>4 Contact</b>	<b>8 Contact</b>				
R4N	Weatherproof	Aluminium alloy*	Drawn steel	316 stainless steel	None	1	1				
S4N	IP66					100mm	4	2			
L4N						200mm	6	3			
R7A	Flameproof	Aluminium alloy*	Aluminium alloy			None	1	1			
S7A	EExdIICT6					100mm	4	2			
R71		Cast iron	Cast iron			None	1	1			
S71				100mm	4	2					
*Base material will be cast iron whenever 8 contact switches specified.											
	<b>Code Number of switch mechanisms</b>										
1-6	As required: see max. number allowable in switch enclosure data above										
	<b>Code Type of switch mechanism</b>										
	<b>Switch mechanism duty</b>	<b>Max. wetside temp.</b>	<b>AC max values</b>			<b>DC max values</b>					
			<b>Volts</b>	<b>Amps</b>	<b>VA</b>	<b>Volts</b>	<b>Res. I</b>	<b>Ind. I</b>	<b>Watts</b>		
	<b>4 contact: 2 x SPST</b>										
D4	General purpose	400°C	440	5	2000	250	5	0.5	50		
P4	Low power circuits	400°C	250	0.25	6	250	0.25	0.1	3.6		
X4	High power circuits	250°C	440	10	2000	250	10	0.5	50		
H4	Hermetically sealed	250°C	440	10	2000	250	10	0.5	50		
	<b>8 contact: DPDT</b>										
D8	General purpose	400°C	440	5	2000	250	5	0.5	50		
P8	Low power circuits	400°C	250	0.25	6	250	0.25	0.1	3.6		
X8	High power circuits	250°C	440	10	2000	250	10	0.5	50		
H8	Hermetically sealed	250°C	440	10	2000	250	10	0.5	50		
	<b>Code Mounting arrangement</b>										
0	1" NPT thread: 316 stainless steel standard										
60	3" # 15ORF ANSI B16.5 / BS1560										
61	3" # 30ORF ANSI B16.5 / BS1560										
62	3" # 60ORF ANSI B16.5 / BS1560										
65	4" # 15ORF ANSI B16.5 / BS1560										
66	4" # 30ORF ANSI B16.5 / BS1560										
67	4" # 60ORF ANSI B16.5 / BS1560										
	These are our stocked flanges. Other flange sizes and ratings are available on request										
D	C	2F	L4N	4	D4 /	67	<b>Typical ordering information</b>				

Note : Instrument pressure rating is the lower of either the float or mounting flange

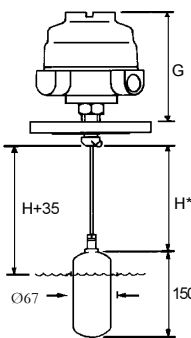
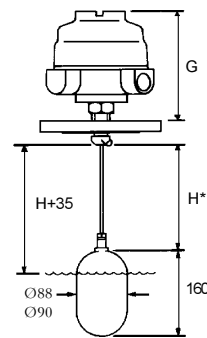

## Direct Mounting Float Dimensions

Floats for 3" NB mounting: 1F				Floats for 4" NB mounting: 2F, 3F, 4F				
 <p><b>1F</b></p>				 <p><b>3F, 4F, 2F</b></p>				
*Float rod may be shortened to suit				*Float rod may be shortened to suit				
H dimension when used with:	1F		Switch adjustment	Wet switching differential	2F 3F 4F		Switch adjustment	Wet switching differential
	minH	maxH			min H	max H		
R4N R7A R7I	155	315	None	20mm	155	415	None	20mm
S4N S7A S7I	155	315	100mm	120mm max.	155	415	100mm	120mm max.
L4N					155	415	20mm	220mm max.

## Switch Enclosures

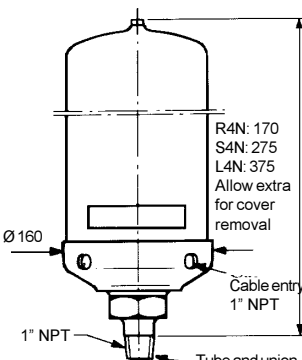
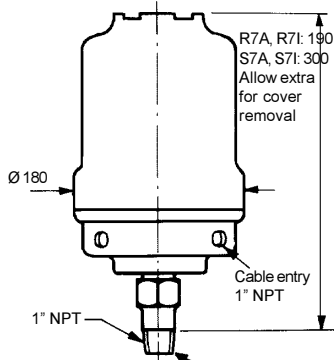
Weatherproof: R4N S4N L4N	Flameproof: R7A R7I S7A S7I
 <p>R4N: 170 S4N: 275 L4N: 375 Allow extra for cover removal</p> <p>Ø160</p> <p>1" NPT</p> <p>Cable entry 1" NPT</p> <p>Tube and union</p>	 <p>R7A, R7I: 190 S7A, S7I: 300 Allow extra for cover removal</p> <p>Ø180</p> <p>1" NPT</p> <p>Cable entry 1" NPT</p> <p>Tube and union</p>

## Switch Mechanisms

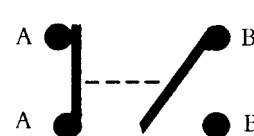
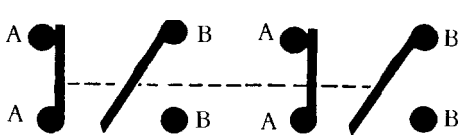
4 Contact D4, P4, X4, H4	8 Contact D8, P8, X8, H8
 <p>2 x independent SPST AA make on rise: BB make on fall</p>	 <p>Double pole double throw (4 x independent SPST) AA make on rise: BB make on fall</p>

### 3.0 Carbon Steel Chamber Mounted Controls: Ordering Information

<b>Code</b>	<b>Chamber mounted controls</b>									
<b>B</b>	Bottle Style: Float sealed inside chamber during manufacture									
<b>X</b>	Flanged Style: Float may be removed from chamber for routine maintenance									
<b>Code</b>	<b>Material of construction of chamber</b>									
<b>C</b>	Carbon steel: See page 15									
<b>Code</b>	<b>Floats</b>									
	<b>Float and trim material</b>	<b>Minimum S.G</b>	<b>Pressure rating (bar). See notes</b>				<b>Chamber body size</b>			
			<b>20°C</b>	<b>250°C</b>	<b>400°C</b>					
<b>1F</b>		0.80	34.5	22.0	20.0	Refer to page 15 for process connection ratings	3" N.B.			
<b>2F</b>	316 stainless steel	0.75	102.1	83.4	69.0					
<b>3F</b>		0.65	51.1	41.7	34.5					
<b>4F</b>		0.54	19.6	12.1	6.5					
<b>7D</b>		0.40	102.1	83.4	69.0	Note: single switch only	4" N.B.			
<b>Code</b>	<b>Switch Enclosure</b>									
	<b>Duty</b>	<b>Material of Base</b>		<b>Cover</b>	<b>Material of wetted parts</b>	<b>Switch adjustment</b>	<b>Max. no. of switches</b>			
							<b>4 Contact</b>	<b>8 Contact</b>		
<b>R4N</b>	Weatherproof IP66	Aluminium alloy*	Drawn steel	316 stainless steel	None	1	1			
<b>S4N</b>						100mm	4	2		
<b>R7A</b>	Flameproof EExdIICT6	Aluminium alloy*	Aluminium alloy		None	1	1			
<b>S7A</b>						100mm	4	2		
<b>R71</b>		Cast iron	Cast iron	Cast iron	None	1	1			
<b>S71</b>	100mm					4	2			
* Base material will be cast iron whenever 8 contact switches are specified										
<b>Code</b>	<b>Number of switch mechanisms</b>									
<b>1 - 4</b>	As required: see max. number allowable in switch enclosure and float data above									
<b>Code</b>	<b>Type of switch mechanism</b>									
	<b>Switch mechanism duty</b>		<b>Max. wetside temperature</b>	<b>A.C. max. values</b>			<b>D.C. max. values</b>			
				<b>Volts</b>	<b>Amps</b>	<b>VA</b>	<b>Volts</b>	<b>Res. I</b>	<b>Ind. I</b>	<b>Watts</b>
	<b>4 Contact: 2 x SPST</b>									
<b>D4</b>	General purpose		400°C	440	5	2000	250	5	0.5	50
<b>P4</b>	Low power circuits		400°C	250	0.25	6	250	0.25	0.1	3.6
<b>X4</b>	High power circuits		250°C	440	10	2000	250	10	0.5	50
<b>H4</b>	Hermetically sealed		250°C	440	10	2000	250	10	0.5	50
	<b>8 Contact: DPDT</b>									
<b>D8</b>	General purpose		400°C	440	5	2000	250	5	0.5	50
<b>P8</b>	Low power circuits		400°C	250	0.25	6	250	0.25	0.1	3.6
<b>X8</b>	High power circuits		250°C	440	10	2000	250	10	0.5	50
<b>H8</b>	Hermetically sealed		250°C	440	10	2000	250	10	0.5	50
	/									
<b>Code</b>	<b>Process connection configuration</b>									
<b>1</b>	Side/bottom									
<b>2</b>	Side/side with 1" NPT dram									
<b>Code</b>	<b>Process connection size &amp; rating</b>					<b>Chamber</b>				
<b>01</b>	1" N.P.T.: 316 s/s standard					3" & 4" N.B.	These are our stocked sizes			
<b>11</b>	1" # 150 R.F.									
<b>12</b>	1" # 300 R.F.									
<b>13</b>	1" # 600 R.F.									
<b>15</b>	DN25 PN16									
<b>16</b>	DN25 PN25									
<b>17</b>	DN25 PN40									
<b>18</b>	DN25 PN64									
<b>19</b>	DN25 PN100									
<b>21</b>	1½" # 150 R.F.					4" N.B. only	Instrument pressure rating is the lower of either the float or process flange			
<b>22</b>	1½" # 300 R.F.									
<b>23</b>	1½" # 600 R.F.									
<b>25</b>	DN40 PN16									
<b>31</b>	2" # 150 R.F.									
<b>32</b>	2" # 300 R.F.									
<b>33</b>	2" # 600 R.F.									
<b>35</b>	DN50 PN16									
<b>36</b>	DN50 PN25									
<b>37</b>	DN50 PN40									

**X C 4F S7A 2 D4 / 2 10** Typical ordering information

**Note:** State process connection centres when ordering. See page 14 for standard dimensions. Instrument pressure rating is the lower of either the float or the process flange.

## Chamber Type and Material of Construction

Carbon steel: Bottle construction BS	Carbon steel: Flanged construction XS
---	--

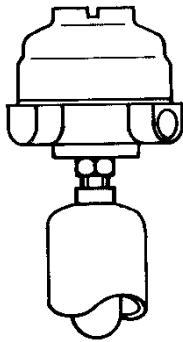

Float is sealed inside chamber during manufacture.

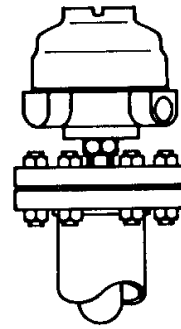

Float may be removed from chamber for routine maintenance, cleaning or inspection.

## Switch Enclosures

Weatherproof: R4N S4N	Flameproof: R7A S7A R71 S71
-----------------------	-----------------------------

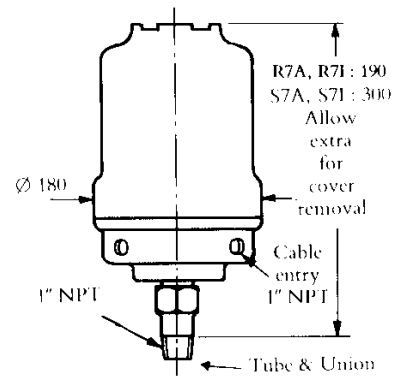
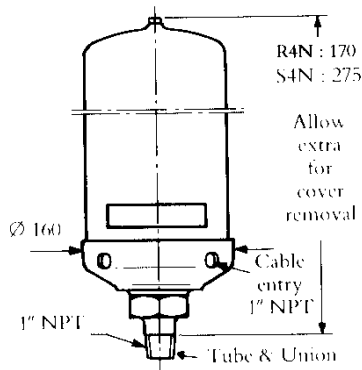

## Switch Mechanisms

4 contact: D4 P4 X4 H4	8 contact: D8 P8 X8 H8
------------------------	------------------------

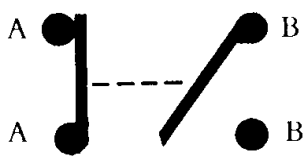

2 × independent SPST  
AA make on rise: BB make on fall

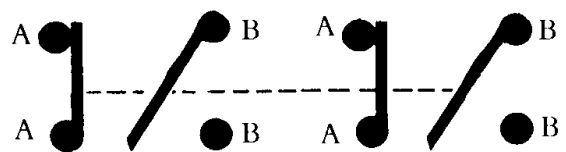

Double pole double throw (4 × independent SPST)  
AA make on rise: BB make on fall

## Process Connection Configuration

Side and Bottom - 1	Side and Side with Drain - 2
---------------------	------------------------------

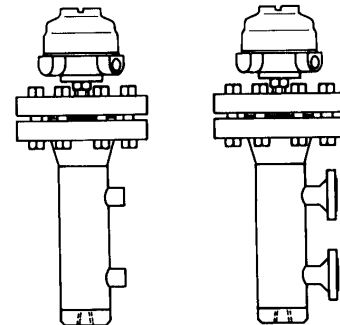
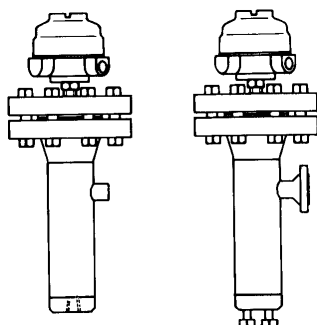

Chamber dimensions, operating levels and technical data are given on page 14

#### 4.0 316L Stainless Steel Chamber Mounted Controls: Ordering Information

<b>Code</b>	<b>Chamber mounted controls</b>									
<b>B</b>	Bottle Style: Float sealed inside chamber during manufacture									
<b>X</b>	Flanged Style: Float may be removed from chamber for routine maintenance									
<b>Code</b>	<b>Material of construction of chamber</b>									
<b>S</b>	316L stainless steel: see page 15									
<b>Code</b>	<b>Floats</b>									
	<b>Float and trim material</b>	<b>Minimum S.G</b>	<b>Pressure rating (bar). See notes</b>				<b>Chamber body size</b>			
			<b>20°C</b>	<b>250°C</b>	<b>400°C</b>					
<b>2F</b>	316 stainless steel	0.75	82.7	57.4	46.3	Refer to page 15 for process connection ratings Note: single switch only	4" N.B.			
<b>3F</b>		0.65	41.4	26.7	23.2					
<b>4F</b>		0.54	15.9	10.2	6.5					
<b>7D</b>		0.40	82.7	57.4	46.3					
<b>Code</b>	<b>Switch Enclosure</b>									
	<b>Duty</b>	<b>Material of</b>		<b>Material of</b>	<b>Switch</b>	<b>Max. no. of switches</b>				
		<b>Base</b>	<b>Cover</b>	<b>wetted parts</b>	<b>adjustment</b>	<b>4 Contact</b>	<b>8 Contact</b>			
<b>R4N</b>	Weatherproof IP66	Aluminium alloy*	Drawn steel	316 stainless steel	None	1	1			
<b>S4N</b>					100mm	4	2			
<b>R7A</b>	Flameproof EExdIICT6	Aluminium alloy*	Aluminium alloy		None	1	1			
<b>S7A</b>					100mm	4	2			
<b>R71</b>		Cast iron	Cast iron	None	1	1				
<b>S71</b>	100mm			4	2					
* Base material will be cast iron whenever 8 contact switches are specified										
<b>Code</b>	<b>Number of switch mechanisms</b>									
<b>1 - 4</b>	As required: see max. number allowable in switch enclosure and float data above									
<b>Code</b>	<b>Type of switch mechanism</b>									
	<b>Switch mechanism duty</b>		<b>Max. wetside temperature</b>	<b>A.C. max. values</b>			<b>D.C. max. values</b>			
				<b>Volts</b>	<b>Amps</b>	<b>VA</b>	<b>Volts</b>	<b>Res. I</b>	<b>Ind. I</b>	<b>Watts</b>
	<b>4 Contact: 2 x SPST</b>									
<b>D4</b>	General purpose		400°C	440	5	2000	250	5	0.5	50
<b>P4</b>	Low power circuits		400°C	250	0.25	6	250	0.25	0.1	3.6
<b>X4</b>	High power circuits		250°C	440	10	2000	250	10	0.5	50
<b>H4</b>	Hermetically sealed		250°C	440	10	2000	250	10	0.5	50
	<b>8 Contact: DPDT</b>									
<b>D8</b>	General purpose		400°C	440	5	2000	250	5	0.5	50
<b>P8</b>	Low power circuits		400°C	250	0.25	6	250	0.25	0.1	3.6
<b>X8</b>	High power circuits		250°C	440	10	2000	250	10	0.5	50
<b>H8</b>	Hermetically sealed		250°C	440	10	2000	250	10	0.5	50
/										
<b>Code</b>	<b>Process connection configuration</b>									
<b>1</b>	Side/bottom									
<b>2</b>	Side/side with 1" NPT dram									
<b>Code</b>	<b>Process connection size &amp; rating</b>									
<b>01</b>	1" N.P.T. 316 stainless steel standard									
<b>11</b>	1" # 150 R.F. ANSI B16.5/BS1560									
<b>12</b>	1" # 300 R.F. ANSI B16.5/BS1560									
<b>13</b>	1" # 600 R.F. ANSI B16.5/BS1560									
<b>21</b>	1½" # 150 R.F. ANSI B16.5/BS1560									
<b>22</b>	1½" # 300 R.F. ANSI B16.5/BS1560									
<b>23</b>	1½" # 600 R.F. ANSI B16.5/BS1560									
<b>31</b>	2" # 150 R.F. ANSI B16.5/BS1560									
<b>32</b>	2" # 300 R.F. ANSI B16.5/BS1560									
<b>33</b>	2" # 600 R.F. ANSI B16.5/BS1560									
<b>B</b>	<b>S</b>	<b>7D</b>	<b>4N</b>	<b>1</b>	<b>X8</b>	<b>/</b>	<b>2</b>	<b>33</b>	<b>Typical ordering information</b>	

Note: State process connection centres when ordering. See page 14 for standard dimensions. Instrument pressure rating is the lower of either the float or the process flange.

## Chamber Type and Material of Construction

Carbon steel: Bottle construction BC	Carbon steel: Flanged construction XC
---	--

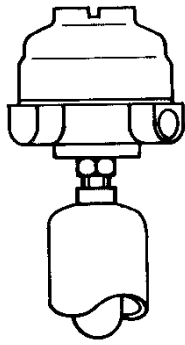

Float is sealed inside chamber during manufacture.

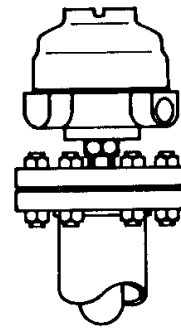

Float may be removed from chamber for routine maintenance, cleaning or inspection.

## Switch Enclosures

Weatherproof: R4N S4N	Flameproof: R7A S7A R71 S71
-----------------------	-----------------------------

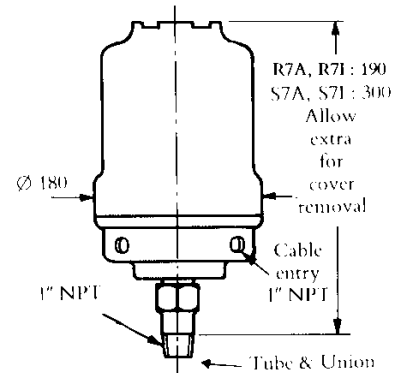
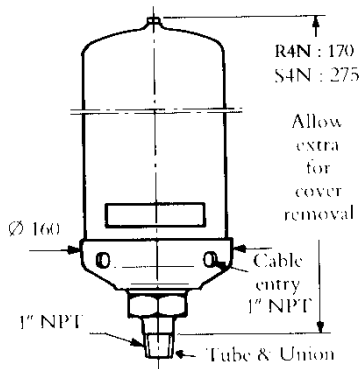

## Switch Mechanisms

4 contact: D4 P4 X4 H4	8 contact: D8 P8 X8 H8
------------------------	------------------------

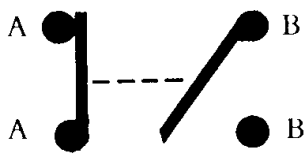

2 × independent SPST  
AA make on rise: BB make on fall

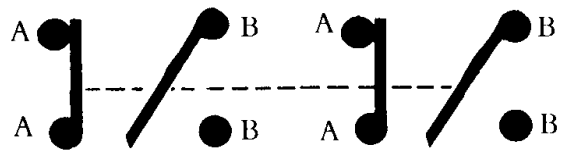

Double pole double throw (4 × independent SPST)  
AA make on rise: BB make on fall

## Process Connection Configuration

Side and Bottom - 1	Side and Side with Drain - 2
---------------------	------------------------------

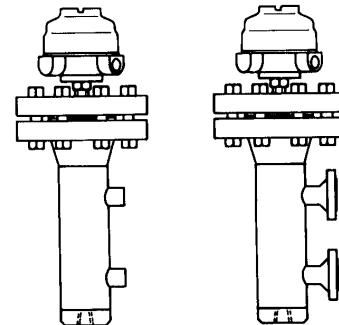
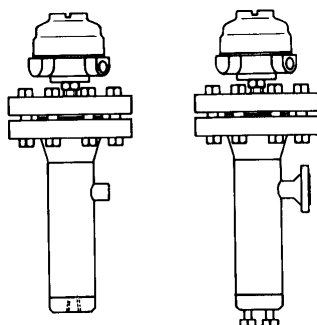

Chamber dimensions, operating levels and technical data are given on page 14

## Dimensional and Operating Level Data

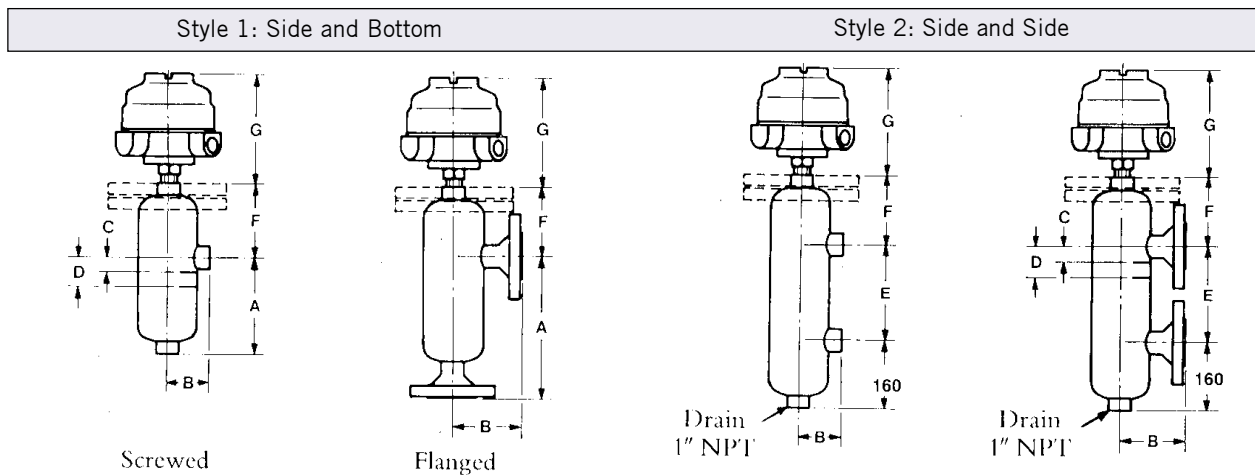

Process connections	A		B*	C	D		E		F	
	Single switch 'R' head	Multi-type 'S' head	Chamber type BC/others		Single switch 'R' head	Multi-switch 'S' head	Single switch 'R' head	Multi-switch 'S' head	Chamber type	
									BC/BS	XC/XS
1" NPT (side/bottom)	300	385	76/95	50	70	155	-	-	48/160	225
1" NPT (side/side)	-	-	95	50	70	155	271	356	160	225
1" 150	356	441	110	50	70	155	271	356	160	225
1" 300	356	441	117	50	70	155	271	356	160	225
1" 600	356	441	123	50	70	155	271	356	160	225
DN25 PN16	356	441	94	50	70	155	271	356	160	225
DN25 PN25	356	441	96	50	70	155	271	356	160	225
DN25 PN40	356	441	96	50	70	155	271	356	160	225
DN25 PN64	356	441	114	50	70	155	271	356	160	225
DN25 PN100	356	441	114	50	70	155	271	356	160	225
1½" 150	356	441	115	50	70	155	271	356	160	225
1½" 300	356	441	121	50	70	155	271	356	160	225
1½" 600	356	441	126	50	70	155	271	356	160	225
DN40 PN16	356	441	97	50	70	155	271	356	160	225
2" 150	356	441	112	50	70	155	271	356	160	225
2" 300	356	441	118	50	70	155	271	356	160	225
2" 600	356	441	129	50	70	155	271	356	160	225
DN50 PN16	356	441	98	50	70	155	271	356	160	225
DN50 PN25	356	441	101	50	70	155	271	356	160	225
B* Dimension given is for 4" NB chamber (2F, 3F, 4F & 7D Floats). For 3" NB chamber (1F Float) subtract 13mm.										
<b>Operating levels: Type 7D float in any chamber.</b>										
Operating S.G.	0.4	0.5	0.6	0.7	0.8	0.9	1.0	1.1	1.2	
Dimension C	65	73	82	91	100	109	118	127	136	
Dimension D	118	122	127	132	137	141	147	152	156	

**Notes:** C = Highest operating liquid level

D (Multi switch) = Lowest operating liquid level

D (Single switch) = Reset level

D-C = Wet switching differential (max)

All dimensions in mm.

**NOTE:** Dimensions given are for reference only, and must be certified on order.

Dimensional data: enclosures					
Type	Duty	Height G	Conduit thread*	Switch adjustment	Weatherproof rating
R7A, R71	Flameproof	190	1" NPT	None	IP66 to IEC 144 (NEMA 4)
S7A, S71	EExdIICT6	300		100	
R4N	Weatherproof	170	1" NPT	None	IP66 to IEC 144 (NEMA 4)
S4N		275		100	
L4N		375		200	

\*Enclosures for use with 8 contact switch mechanisms have both conduit entries threaded, whilst those for use with 4 contact switch mechanisms have only one conduit entry.

## Technical Data

Mobrey vertical level controls are manufactured to the highest standards of quality with only certified materials: BS EN 10204 3.1B. Design of Mobrey chambers is in accordance with ANSI B31.3.

Welding is qualified to ASME IX, BS4870 and BS4871. Circumferential and set-on branch welds are full penetration welds, with visual inspection in accordance with ANSI B31.3 "normal service" requirements and our company standard 417.

All pressure retaining assemblies are hydrostatically pressure tested to a minimum of 1.25 x maximum working pressure or to flange standard requirements.

Radiography or other NDT techniques can be accommodated provided that they are specific at time of order entry.

### Inspection

Whilst Mobrey employ inspectors in house, unconnected with production, customers frequently ask for outside inspection. We are happy to accommodate nominated inspectors if agreed at order entry.

Some specifications require a quality control plan detailing inspection points and hold points. Mobrey will produce these QC plans for customer approval if agreed at order entry.

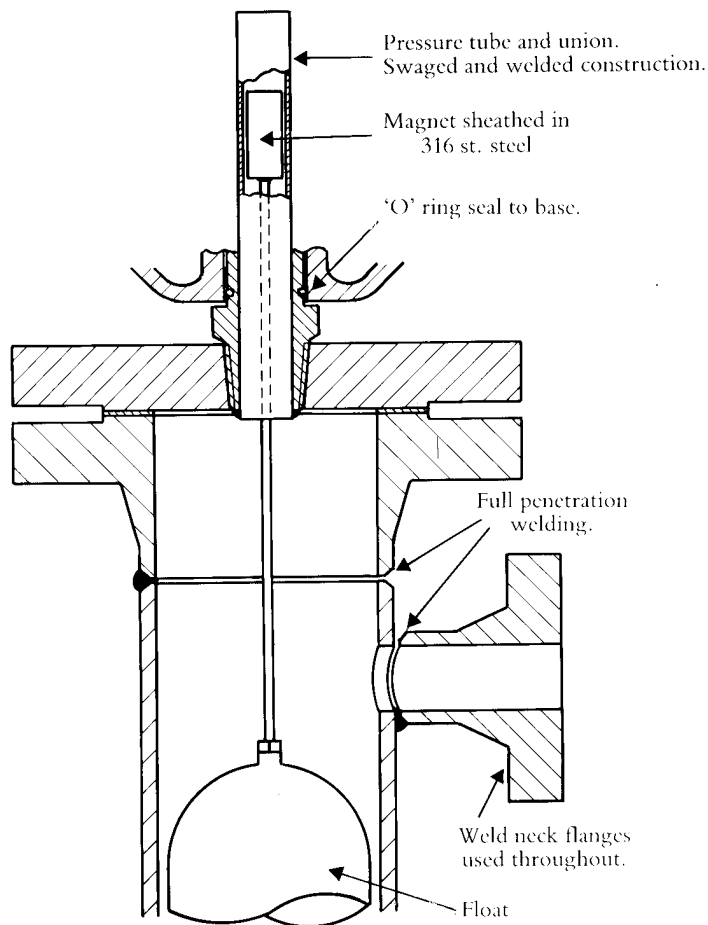

### Pressure Ratings (bar)

Material	Carbon steel: A105			Stainless steel: 316L		
	20°C	250°C	400°C	20°C	250°C	400°C
ANSI # 150	19.6	12.1	6.5	15.9	10.2	6.5
ANSI # 300	51.1	41.7	34.5	41.4	26.7	23.2
ANSI # 600	102.1	83.4	69.0	82.7	57.4	46.3
BS4504 PN16	16	14.4	8.8	15.2	9.9	8.4
BS4504 PN25	25	22.5	13.8	23.8	15.5	13.2
BS4504 PN40	40	36	22	38	24.8	21.1

### Technical specification

Materials of construction	Carbon steel chamber	Stainless steel chamber
Chamber tube	ASTM A106 Gr B / BS3602 HFS410	ASTM A312 T316L / BS3605-316-S14
Top casting	ASTM A216 / BS1504-161-430A	-
Top/bottom caps	ASTM A105 / BS1503-221-430E	ASTM A182 F316L / BS1503-316-S13
Top cover	ASTM A105 / BS1503-221-430E	ASTM A182 F316L / BS1503-316-S13
Flanges/fittings	ASTM A105 / BS1503-221-430E	ASTM A182 F316L / BS1503-316-S13
Studs	ASTM A193-B7 / BS1506-621A-B7	ASTM A193-B7 / BS1506-621A-B7
Nuts	ASTM A194-2H / BS1506-162-2H	ASTM A192-2H / BS1506-162-2H
Standard chambers +400°C to -10°C. Low temperature chambers below -10°C upon request		

### Options

- Low temperature carbon steel
- Cr. mo. steels
- Duplex UNS31803
- Ratings up to ANSI #2500
- N.A.C.E. requirements
- N.D.T. to your specifications
- 3.1b Identifiable certification
- Vent and drain connections
- Process connections to specification