

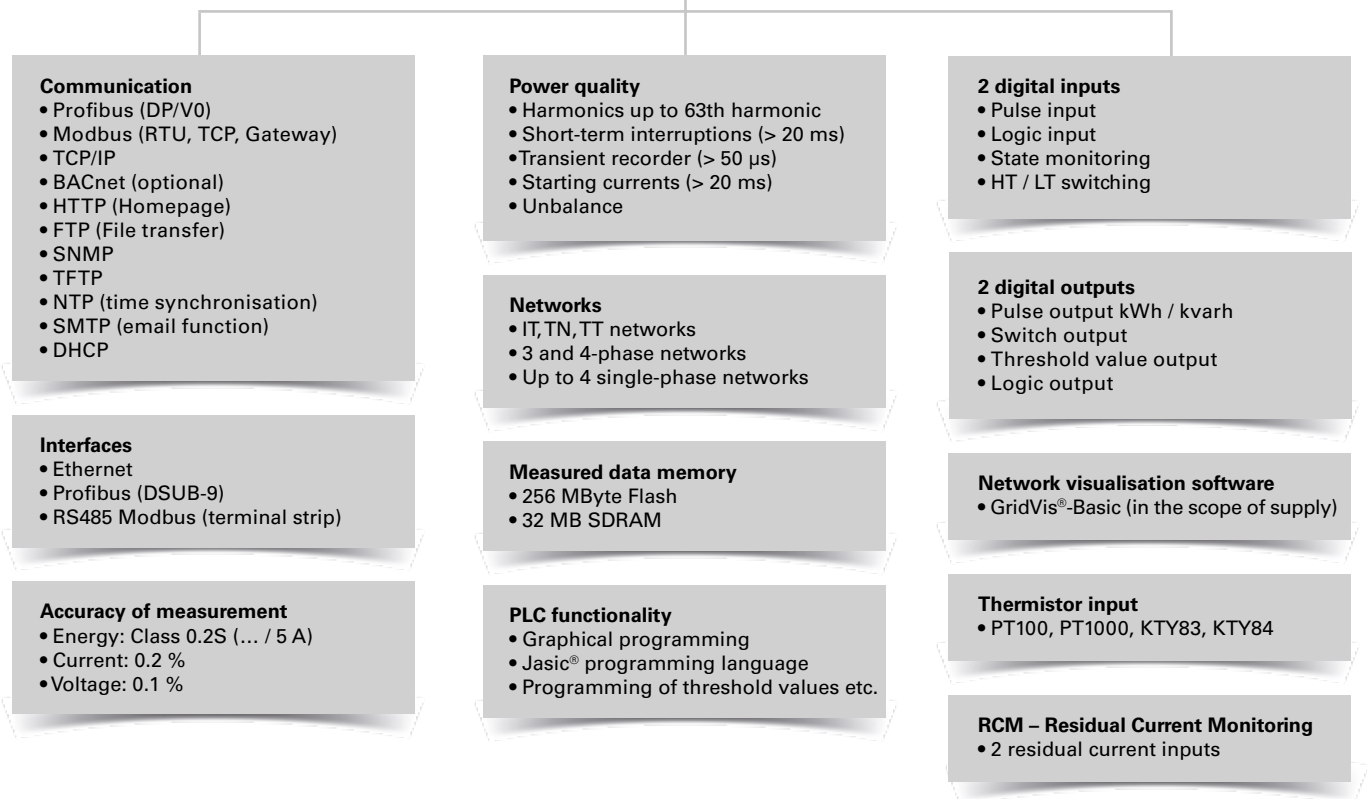

UMG 509 – Multifunction power analyser with RCM





Areas of application



- Continuous monitoring of the power quality
- Energy management systems (ISO 50001)
- Master device with Ethernet gateway for subordinate measurement points
- Visualisation of the energy supply in the LVDB
- Analysis of electrical disturbances in the event of power quality problems
- Cost centre analysis
- Remote monitoring in the property operation
- Use in test fields (e.g. in universities)

Main features

High quality measurement with high sampling rate (20 kHz per channel)



Power quality

- Harmonics analysis up to 63rd harmonic
- Acquisition of short-term interruptions
- Acquisition of transients
- Display of waveforms (current and voltage)
- Unbalance
- Vector diagram



RCM (Residual Current Monitoring)

- Continuous monitoring of residual currents (Residual Current Monitor, RCM)
- Alarming in case a preset threshold fault current reached
- Near-realtime reactions for triggering countermeasures
- Permanent RCM measurement for systems in permanent operation without the opportunity to switch off
- Ideal for the central earthing point in TN-S systems



Modern communications architecture via Ethernet

- Ethernet interface and web server
- Faster, better cost-optimised and more reliable communication system
- High flexibility due to the use of open standards
- Integration in PLC systems and BMS through additional interfaces
- BACnet optionally available
- Up to 4 ports simultaneous
- Versatile IP protocols

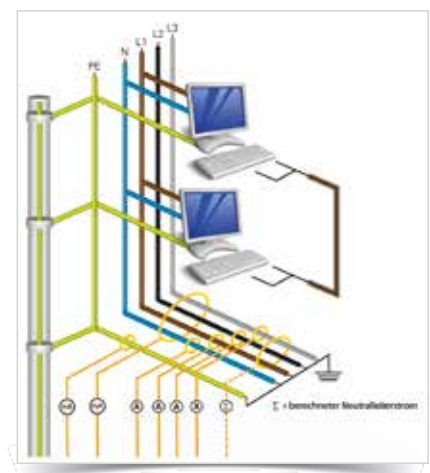

Fig.: Example RCM measurement



Modbus Gateway function

- Economical connection of devices without Ethernet interface
- Integration of devices with Modbus-RTU interface possible
- Data can be scaled and described
- Minimised number of IP addresses required

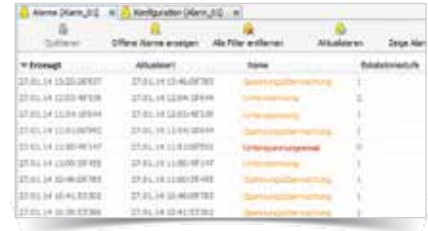

Fig.: GridVis® – Alarmmanagement



Graphical programming

- Comprehensive programming options (PLC functionality)
- Jasic® source code programming
- Sustainable functional expansions far beyond pure measurement
- Complete APPs from the Janitza library



Powerful alarm management

- Can be programmed via the graphic programming or Jasic® source code
- All measured values can be used
- Can be arbitrarily, mathematically processed
- Individual forwarding via email sending, switching of digital outputs, writing to Modbus addresses etc.
- Watchdog APPs
- Further alarm management functions via GridVis®-Service alarm management



Dimension diagrams

All dimensions in mm

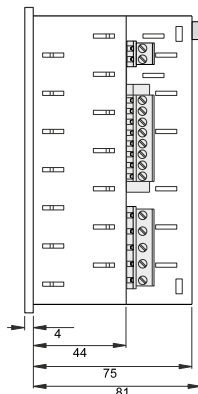

Side view

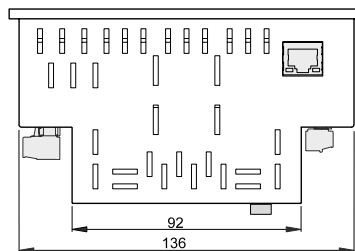

View from below

Cut out: 138^{+0,8} x 138^{+0,8} mm



Ethernet connection



Typical connection

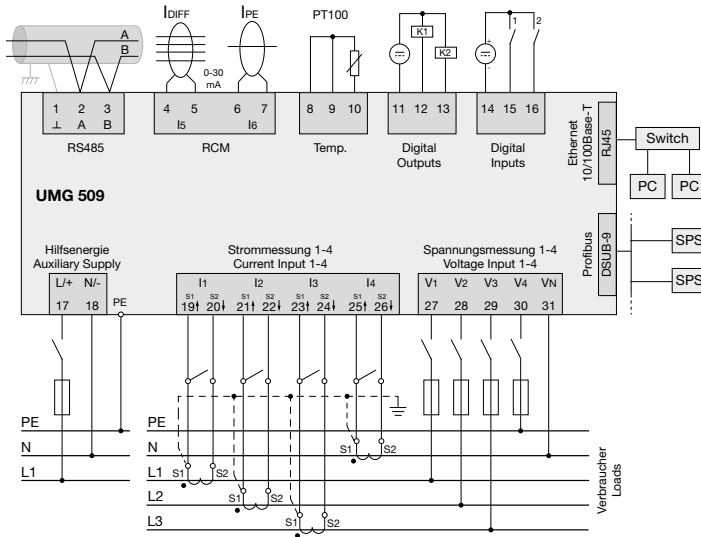

Device overview and technical data

Item number	UMG 509	
	52.26.001	52.26.003
Supply voltage AC	95 ... 240 V AC	48 ... 110 V AC
Supply voltage DC	80 ... 300 V DC	24 ... 150 V DC
Device options		
BACnet communication	52.21.081	52.21.081
General		
Use in low, medium and high voltage networks		•
Accuracy voltage measurement		0.1 %
Accuracy current measurement		0.2 %
Accuracy active energy (kWh, .../5 A)		Class 0.2S
Number of measurement points per period		400
Uninterrupted measurement		•
RMS - momentary value		
Current, voltage, frequency		•
Active, reactive and apparent power / total and per phase		•
Power factor / total and per phase		•
Energy measurement		
Active, reactive and apparent energy [L1, L2, L3, L4, Σ L1-L3, Σ L1-4]		•
Number of tariffs		8
Recording of the mean values		
Voltage, current / actual and maximum		•
Active, reactive and apparent power / actual and maximum		•
Frequency / actual and maximum		•
Demand calculation mode (bi-metallic function) / thermal		•
Other measurements		
Operating hours measurement		•
Clock		•
Weekly timer		Jasic®
Power quality measurements		
Harmonics per order / current and voltage		1st – 63rd
Harmonics per order / active and reactive power		1st – 63rd
Distortion factor THD-U in %		•
Distortion factor THD-I in %		•

Comment:
For detailed technical information please refer to the operation manual and the Modbus address list

• = included - = not included

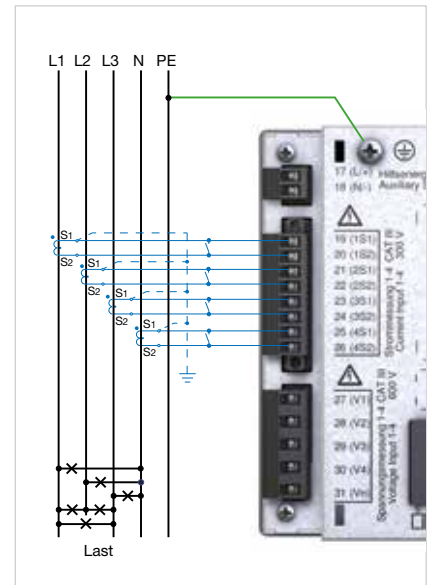

Fig.: Example current measurement



Fig.: Example for the configuration of current measurement via 3 current transformers in a three-phase 4-wire network on the UMG 509 display

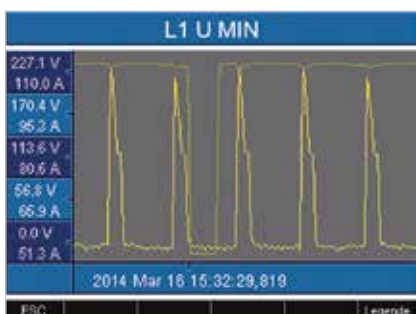

Fig.: Illustration of the full wave effective values for an event (voltage drop)

Comment:
For detailed technical information please refer to the operation manual and the Modbus address list.

• = included - = not included

*1 Optional additional functions with the packages GridVis®-Professional, GridVis®-Service and GridVis®-Ultimate.

*2 With UL variants: 347/600 V

Voltage unbalance	•
Rotary field indication	•
Current and voltage, positive, zero and negative sequence component	•
Transients	> 50 µs
Error / event recorder function	•
Short-term interruptions	20 ms
Oscillogram recording (waveform U and I)	•
Full wave effective values (U, I, P, Q)	•
Under and overvoltage recording	•
Measured data recording	
Memory (Flash)	256 MB
Average, minimum, maximum values	•
Measured data channels	10
Alarm messages	•
Time stamp	•
Time basis average value	freely user-defined
RMS averaging, arithmetic	•
Displays and inputs / outputs	
LCD colour graphical display 320 x 240, 256 colours, 6 buttons	•
Language selection	•
Digital inputs	2
Digital outputs (as switch or pulse output)	2
Voltage and current inputs	each 4
Residual current inputs	2
Temperature input	1
Password protection	•
Communication	
Interfaces	
RS485: 9.6 – 921.6 kbps (terminal board)	•
Profibus DP: Up to 12 Mbps (DSUB-9-plug)	•
Ethernet 10/100 Base-TX (RJ-45 socket)	•
Protocols	
Modbus RTU, Modbus TCP, Modbus RTU over Ethernet	•
Modbus Gateway for Master-Slave configuration	•
Profibus DP V0	•
HTTP (homepage configurable)	•
SMTP (email)	•
NTP (time synchronisation)	•
TFTP	•
FTP (File-Transfer)	•
SNMP	•
DHCP	•
TCP/IP	•
BACnet (optional)	•
ICMP (Ping)	•
Software GridVis®-Basic¹	
Online and historic graphs	•
Databases (Janitza DB, Derby DB); MySQL, MS SQL with higher GridVis® versions)	•
Manual reports (energy, power quality)	•
Graphical programming	•
Topology views	•
Manual read-out of the measuring devices	•
Graph sets	•
Programming / threshold values / alarm management	
Application programs freely programmable	7
Graphical programming	•
Programming via source code Jasic®	•
Technical data	
Type of measurement	Constant true RMS Up to 63rd harmonic
Nominal voltage, three-phase, 4-conductor (L-N, L-L)	417 / 720 V AC ^{1,2}
Nominal voltage, three-phase, 3-conductor (L-L)	600 V AC
Measurement in quadrants	4
Networks	TN, TT, IT
Measurement in single-phase/multi-phase networks	1 ph, 2 ph, 3 ph, 4 ph and up to 4 times 1 ph
Measured voltage input	
Overvoltage category	600 V CAT III
Measured range, voltage L-N, AC (without potential transformer)	10 ... 600 Vrms

Measured range, voltage L-L, AC (without potential transformer)	18 ... 1000 Vrms
Resolution	0.01 V
Impedance	4 MOhm / phase
Frequency measuring range	40 ... 70 Hz
Power consumption	approx. 0.1 VA
Sampling frequency	20 kHz / phase
Measured current input	
Rated current	1 / 5 A
Resolution	0.1 mA
Measurement range	0.001 ... 7 Amps
Overvoltage category	300 V CAT III
Measurement surge voltage	4 kV
Power consumption	approx. 0.2 VA (Ri = 5 MOhm)
Overload for 1 sec.	120 A (sinusoidal)
Sampling frequency	20 kHz
Residual current / Temperature inputs	
Residual current inputs	2
Measurement range, residual current inputs	0,05 ... 30 mA
Temperature input	1
Digital inputs and outputs	
Number of digital inputs	2
Maximum counting frequency	20 Hz
Reaction time (Jasic® program)	200 ms
Input signal present	18 ... 28 V DC (typical 4 mA)
Input signal not present	0 ... 5 V DC, current < 0.5 mA
Number of digital outputs	2
Switching voltage	max. 60 V DC, 30 V AC
Switching current	max. 50 mA Eff AC / DC
Output of voltage dips	20 ms
Pulse output (energy pulse)	max. 20 Hz
Maximum cable length	up to 30 m unshielded, from 30 m shielded
Mechanical properties	
Weight	1080 g
Device dimensions in mm (H x W x D)	144 x 144 x approx. 81
Battery	Type CR2450, 3 V, Li-Mn
Protection class per EN 60529	Front: IP40; Rear: IP20
Assembly per IEC EN 60999-1 / DIN EN 50022	Front panel installation
Connecting phase (U / I), Single core, multi-core, fine-stranded	0.2 to 2.5 mm ²
Terminal pins, core end sheath	0.2 to 2.5 mm ²
Environmental conditions	
Temperature range	Operation: K55 (-10 ... +55 °C)
Relative humidity	Operation: 0 ... 75 % RH
Operating height	0 ... 2,000 m above sea level
Degree of pollution	2
Installation position	user-defined
Electromagnetic compatibility	
Electromagnetic compatibility of electrical equipment	Directive 2004/108/EC
Electrical appliances for application within particular voltage limits	Directive 2006/95/EC
Equipment safety	
Safety requirements for electrical equipment for measurement, regulation, control and laboratory use – Part 1: General requirements	IEC/EN 61010-1
Part 2-030: Particular requirements for testing and measuring circuits	IEC/EN 61010-2-030
Noise immunity	
Class A: Industrial environment	IEC/EN 61326-1
Electrostatic discharge	IEC/EN 61000-4-2
Voltage dips	IEC/EN 61000-4-11
Emissions	
Class B: Residential environment	IEC/EN 61326-1
Radio disturbanc voltage strength 30 – 1000 MHz	IEC/CISPR11/EN 55011
Radiated interference voltage 0.15 – 30 MHz	IEC/CISPR11/EN 55011
Safety	
Europe	CE labelling
USA and Canada	UL variants available
Firmware	
Firmware update	Update via GridVis® software. Firmware download (free of charge) from the website: http://www.janitza.com

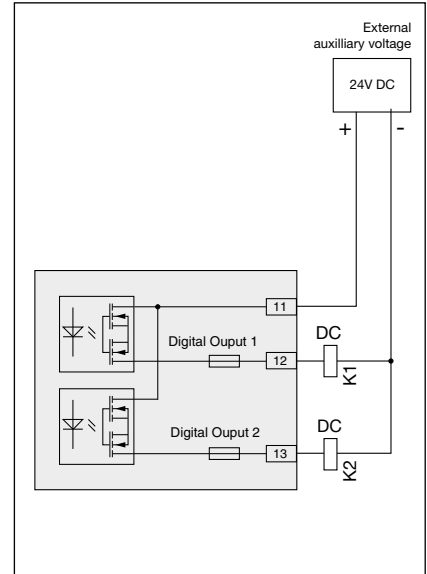

Fig. Example for two electrical relays connected to the digital outputs

Comment:
For detailed technical information please refer to the operation manual and the Modbus address list.

• = included - = not included