

无油式压缩机



曝气压缩机

## GAST 2080 旋片式真空泵,压缩机

### 为什么选择我?

我们是旋片式压缩机与真空泵,具有显著的优势,可以提供流畅且几乎没有脉冲的气流,并不需要气缸,我们结构紧密,安装简单,震动与噪音小,便于维修,并且低电流启动,占用空间很小.



#### 优点

- 无油式26" HG,25CFM,15PSI
- 双功能18" HG,15CFM,9PSI
- 曝气式25~35CFM,15PSI
- 结构坚固
- 维护成本低
- 基本无脉冲 (重型过滤器)

#### 应用

点钞机,曝气设备,呼吸机,纹理喷涂设备,循环治疗设备,磁带驱动空气轴承,天气预报设备,水槽曝气,曝气池,塑料焊接设备,通风设备,家庭污水冲氧处理,呼吸机,电镀槽搅拌,废油燃烧器

#### 规格型号

型号	电机参数	转速RPM		功率		重量
		60Hz	50Hz	HP	KW	
无油式						
2080-V102	不包含	1725	1425	2	1.50	41.0Kg
双功能						
2080-V128-T337	230/460;60-3	1725	----	2	1.50	56.3Kg
2080-D129-T337	230/460;60-3	1725	----	2	1.50	59.4Kg
曝气式						
2080-P124-T337	230/460;60-3	1725	----	2	1.50	60.8Kg





产品尺寸( mm,英寸)

产品性能( 公制,英制)

真空泵

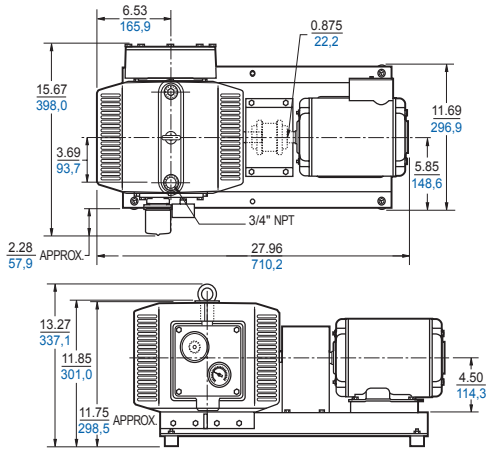

压缩机

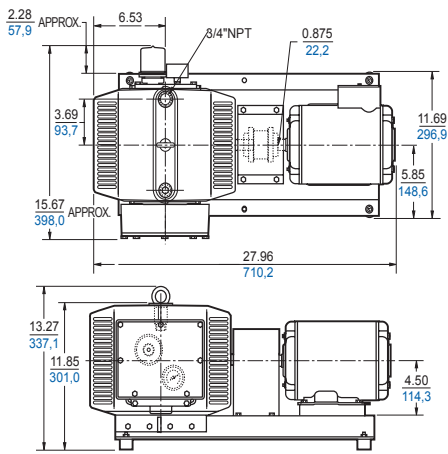

双功能

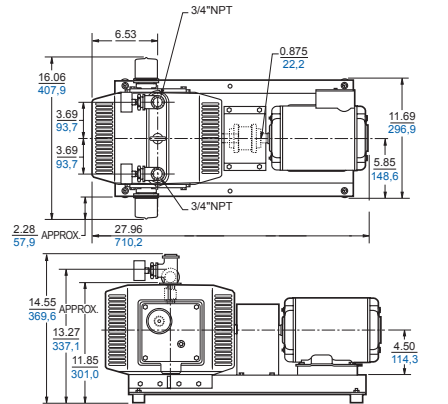

曝气型

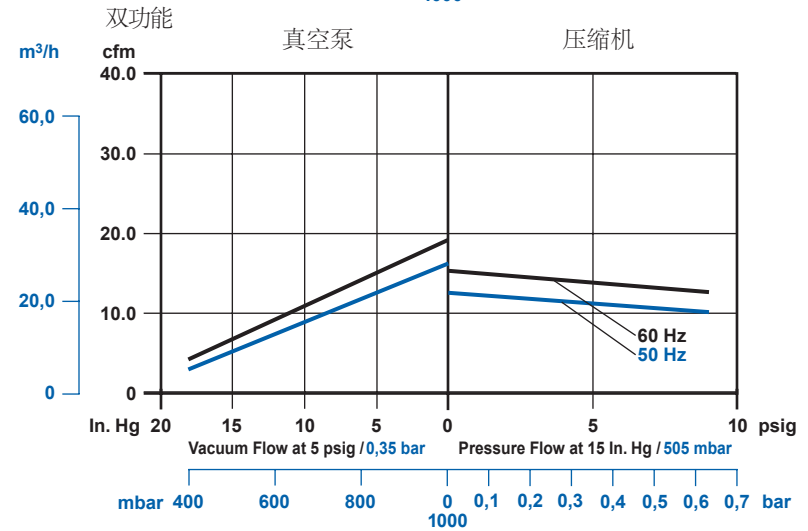
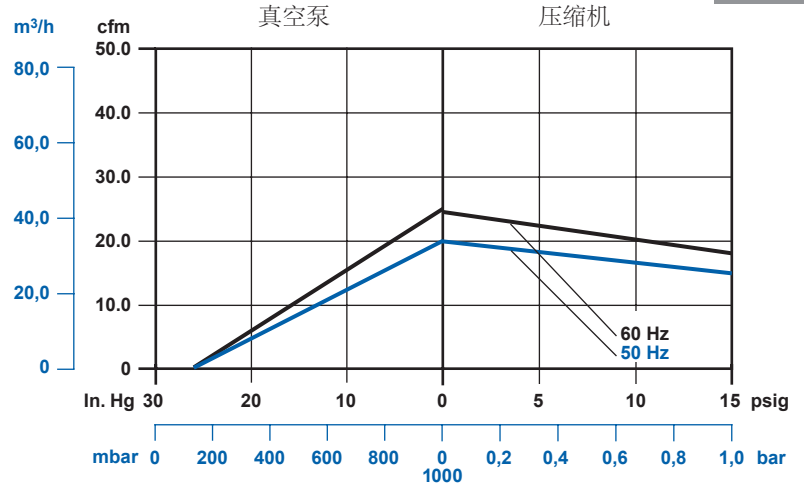
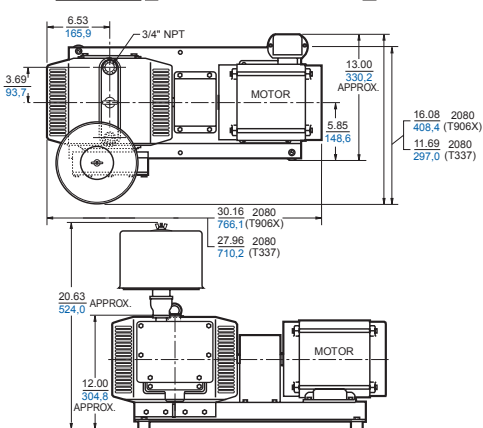

曝气型

