

CO-AM Carbon Monoxide Sensor

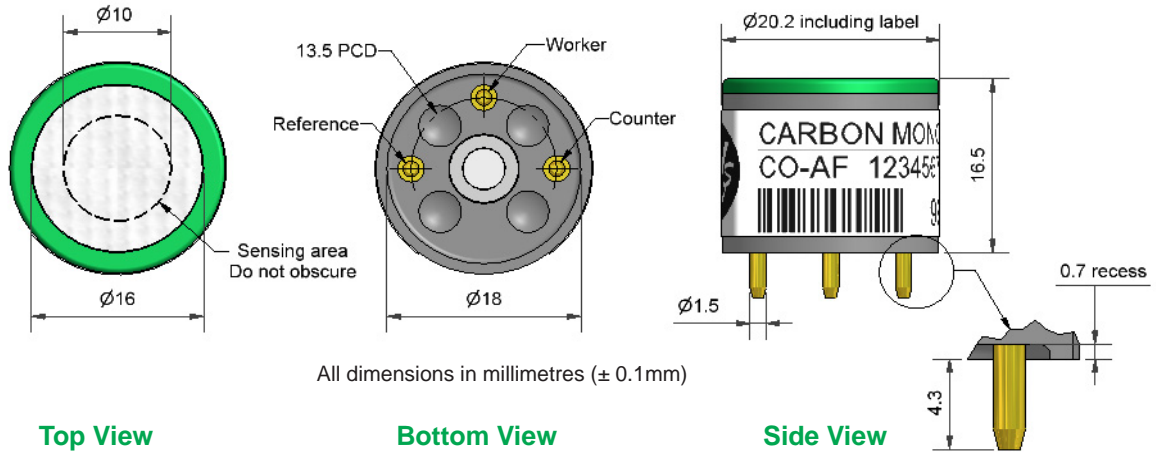

PATENTED

Figure 1 CO-AM Schematic Diagram



Top View

Bottom View

Side View

PERFORMANCE	Sensitivity	nA/ppm in 400ppm CO	55 to 90
	Response time	t ₉₀ (s) from zero to 400ppm CO	< 25
	Zero current	ppm equivalent in zero air	-4 to +2
	Resolution	RMS noise (ppm equivalent)	< 0.5
	Range	ppm CO limit of performance warranty	5,000
	Linearity	ppm error at full scale, linear at zero, 1000ppm CO	+15 to +25
	Overgas limit	maximum ppm for stable response to gas pulse	10,000
LIFETIME	Zero drift	ppm equivalent change/year in lab air	< 0.2
	Sensitivity drift	% change/year in lab air, monthly test	< 8
	Operating life	months until 80% original signal (24 month warranted)	> 24
ENVIRONMENTAL	Sensitivity @ -20°C	% (output @ -20°C/output @ 20°C) @ 400ppm CO	63 to 88
	Sensitivity @ 50°C	% (output @ 50°C/output @ 20°C) @ 400ppm CO	102 to 115
	Zero @ -20°C	ppm equivalent change from 20°C	< ± 3
	Zero @ 50°C	ppm equivalent change from 20°C	< ± 8
CROSS SENSITIVITY	Filter capacity	ppm-hours	H ₂ S 250,000
	Filter capacity	ppm-hours	NO ₂ 600,000
	Filter capacity	ppm-hours	NO 20,000
	Filter capacity	ppm-hours	SO ₂ 300,000
	H ₂ S sensitivity	% measured gas @ 20ppm	H ₂ S < 0.1
	NO ₂ sensitivity	% measured gas @ 10ppm	NO ₂ < 0.1
	Cl ₂ sensitivity	% measured gas @ 10ppm	Cl ₂ < 0.1
	NO sensitivity	% measured gas @ 50ppm	NO < 5
	SO ₂ sensitivity	% measured gas @ 20ppm	SO ₂ < 0.1
	H ₂ sensitivity	% measured gas @ 400ppm	H ₂ at 20°C < 60
	C ₂ H ₄ sensitivity	% measured gas @ 400ppm	C ₂ H ₄ < 25
NH ₃ sensitivity	% measured gas @ 20ppm	NH ₃ < 0.1	
KEY SPECIFICATIONS	Temperature range	°C	-30 to 50
	Pressure range	kPa	80 to 120
	Humidity range	% rh continuous	15 to 90
	Storage period	months @ 3 to 20°C (stored in sealed pot)	6
	Load resistor	Ω (recommended)	10 to 47
	Weight	g	< 6



At the end of the product's life, do not dispose of any electronic sensor, component or instrument in the domestic waste, but contact the instrument manufacturer, Alphasense or its distributor for disposal instructions.

NOTE: all sensors are tested at ambient environmental conditions, with 10 ohm load resistor, unless otherwise stated. As applications of use are outside our control, the information provided is given without legal responsibility. Customers should test under their own conditions, to ensure that the sensors are suitable for their own requirements.

深圳市新世联科技有限公司

CO-AM Performance Data

Technical Specification

Figure 2 Sensitivity Temperature Dependence

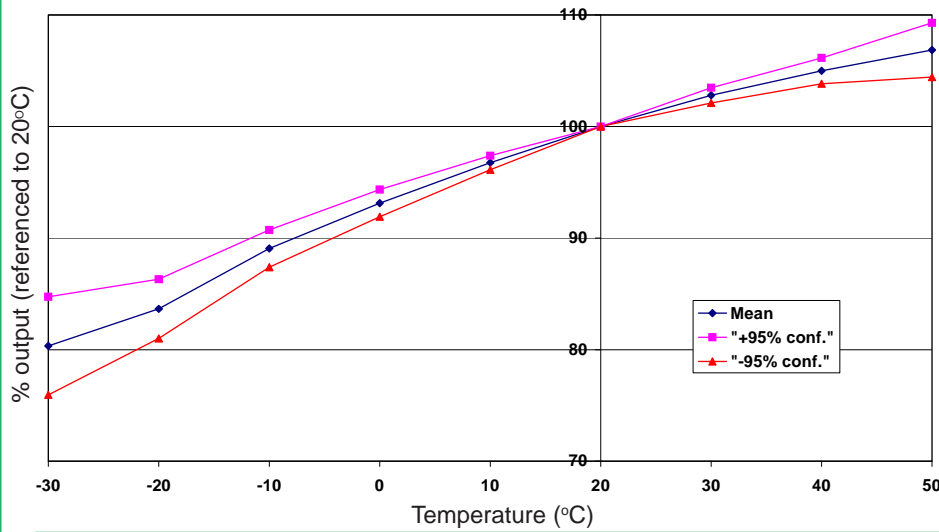

Figure 2 shows the variation in sensitivity caused by changes in temperature.

This data is taken from a typical batch of sensors. The mean and $\pm 95\%$ confidence intervals are shown.

Figure 3 Zero Temperature Dependence

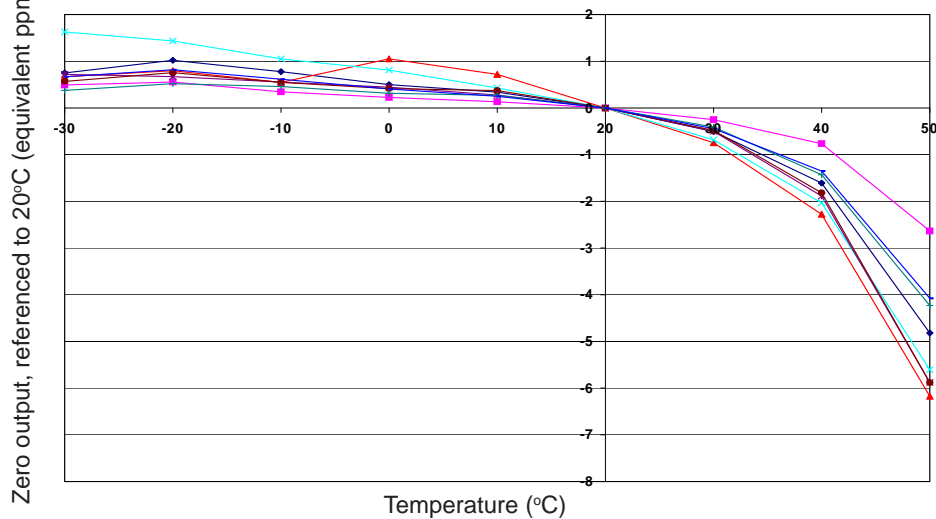

Figure 3 shows the variation in zero output caused by changes in temperature, expressed as ppm gas equivalent, referenced to zero at 20°C.

This data is taken from a typical batch of sensors.

Figure 4 Response to Exposure to 2% CO

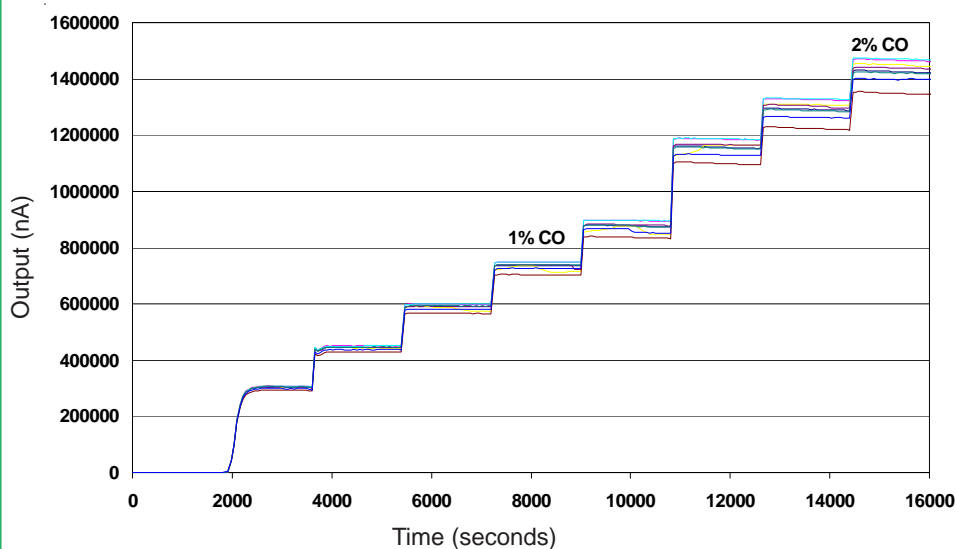

Figure 4 shows the excellent response to step changes in CO concentrations from zero to 2% CO by volume.

This data is taken from a typical batch of sensors.

深圳市新世联科技有限公司