



W45: Farther than the eye can see

	Photoelectric proximity switches, BGS
	Photoelectric reflex switches
	Through-beam photoelectric switches



In harsh environmental conditions, photoelectric switches require a large safety margin in terms of their specification and performance. The W45 series of photoelectric switches easily meets this requirement.

The absolute highlight is the through-beam photoelectric switch with a range of up to 300 m.

A signal strength indicator in conjunction with an integrated viewfinder facilitates adjustment over such long scanning ranges.

The solid metal housing can withstand flying scale in steel and rolling mills, for example, and can be used in conjunction with cooling jacket accessories in temperatures up to +120°C.

A further plus is the simplicity of operation, e.g. easily accessible terminal chamber as well as the additional functionality provided by timing elements.

The comprehensive range of accessories such as cooling plates, weather hood and dust shield means that the performance is further increased and the range of applications is further extended.

Overview of W45:

- Solid metal housing for harsh industrial applications,
- Super range of the through-beam photoelectric switch of 300 m,
- Accessories for specialist applications,
- Universal supply voltage,
- On request: specialist devices for detecting very hot surfaces (>800 °C).

Main industries:

- Steel industry,
- Plant construction,
- Crane systems,
- Transport technology.

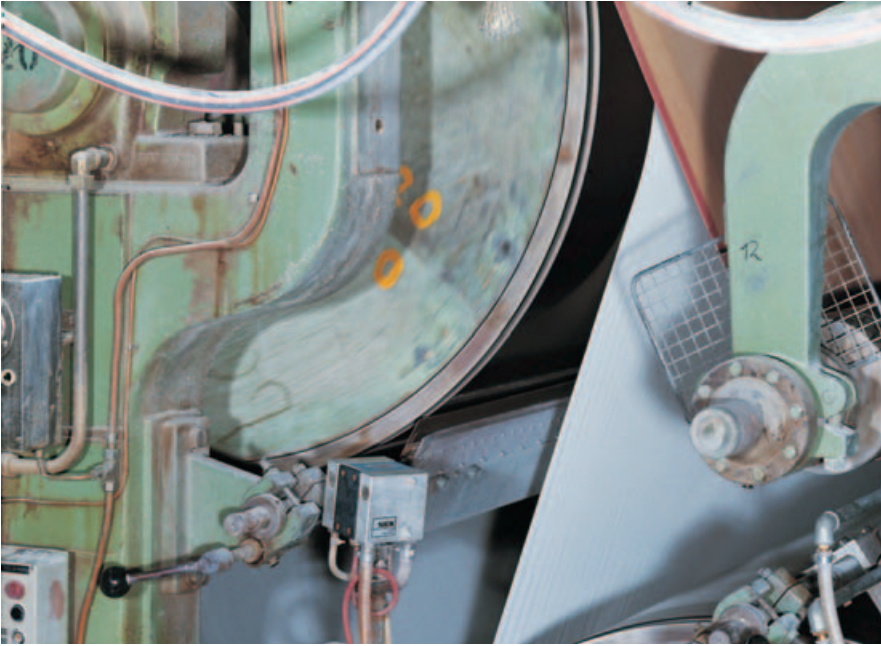

◀ The robust design and large scanning distance are of advantage to the WT45 photoelectric proximity switch when used to check for tear-off on a paper rolling machine.



▶ A WS/WE45 through-beam photoelectric switch monitors tear-off on a paper web.



▶ Scale, steam and heat in a rolling mill does not affect the WT45 – here used to detect the presence of steel slabs.

▲ Extreme operating conditions exist in steel making plants – the WT45 photoelectric proximity switch is ideal for many applications, such as detecting metal sheets before they are wound onto coils.

Scanning distance
400 ... 2000 mm

Photoelectric proximity switches

- Robust metal housing
- Infrared light, very long scanning range
- Adjustable background suppression
- Front lens heating, optional

Dimensional drawing

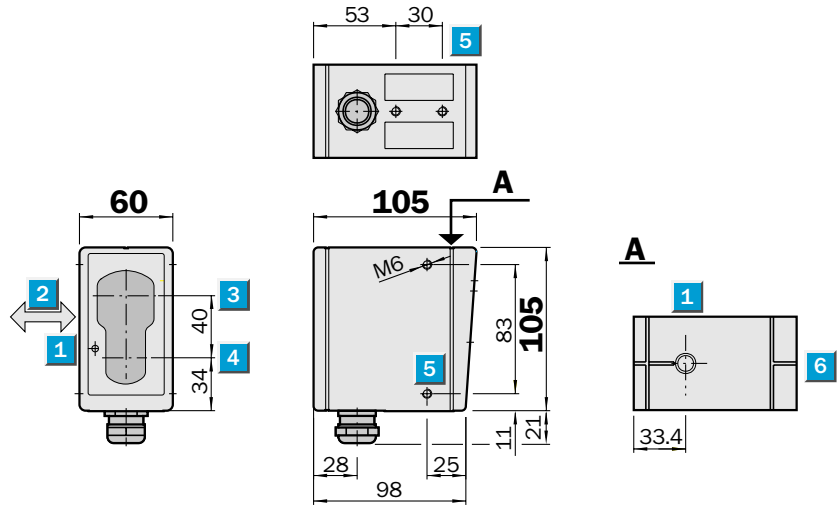

Adjustments possible

- WT45-P250
- WT45-P260
- WT45-N250
- WT45-N260

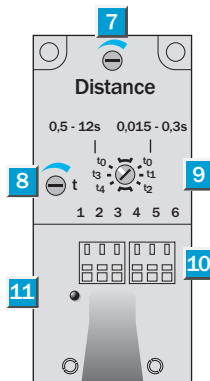

- 1 LED signal strength indicator
- 2 Standard direction of the material being scanned
- 3 Centre of optical axis, receiver
- 4 Centre of optical axis, sender
- 5 Threaded mounting hole M6 – 8 mm deep
- 6 Alignment sight
- 7 Scanning distance adjustment
- 8 Time adjustment
- 9 Time delay selector switch
- 10 Terminal strip
- 11 Status indicator

Switch-selectable time delay

0.5 – 12 s

- t₀ without time delay
- t₃ ON-delay when object enters detection zone
- t₄ OFF-delay when object leaves detection zone

0.015 – 0.3 s

- t₀ without time delay
- t₁ ON-delay when object enters detection zone
- t₂ OFF-delay when object leaves detection zone

Connection type

- WT45-P250
- WT45-P260
- WT45-N250
- WT45-N260

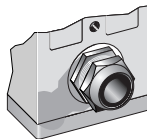

PG 13.5; terminals

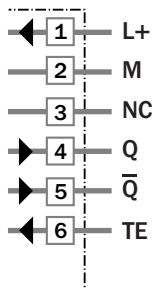

See chapter Accessories

- Mounting systems
- Special accessories

Technical data		WT45-	P250	P260	N250	N260						
Scanning distance	400...2000 mm, adjustable											
Light source¹⁾, light type	LED, infrared light											
Light spot diameter	Approx. 35 mm at 2000 mm											
Supply voltage V_S	10...60 V DC ²⁾											
Residual ripple ³⁾	< 5 V_{SS}											
Current consumption ⁴⁾	≤ 50 mA											
	≤ 250 mA, front lens heating											
Switching outputs	PNP, Q and \bar{Q}											
	NPN, Q and \bar{Q}											
Output current I_A max.	200 mA											
Response time ⁵⁾	6 ms											
Max. switching frequency ⁶⁾	50/s											
Test input »TE«												
Sender OFF	PNP: Test input to 0 V											
	NPN: Test input to V_S											
Connection type	Terminal connection											
VDE protection class	⊕											
Circuit protection⁷⁾	A, B, C											
Enclosure rating	IP 67											
Ambient temperature T_A⁸⁾	Operation - 25 °C...+ 55 °C											
	Storage - 40 °C...+ 70 °C											
Weight	Approx. 800 g											
Front lens heating												
Housing material	Metal housing											

1) Average service life 100,000 h at $T_A = + 25 °C$
 2) Limit values
 3) May not exceed or fall short of V_S tolerances

4) Without load
 5) Signal transit time with resistive load
 6) With light/dark ratio 1:1

7) A = V_S connections reverse-polarity protected
 B = Output Q and \bar{Q} short-circuit protected
 C = Interference pulse suppression

8) Up to 140 °C with cooling plates (see Accessories)

Scanning distance

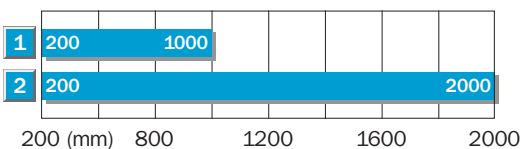

- 1 Scanning distance on black, 6 % remission
- 2 Scanning distance on grey, 18 % remission

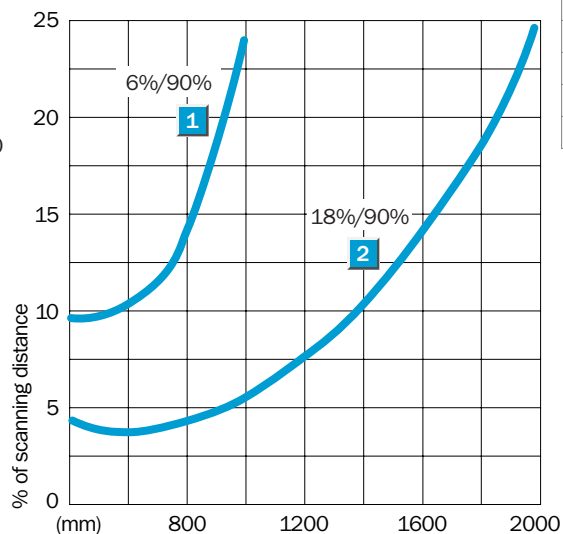

Order Information

Type	Order no.
WT45-P250	1009117
WT45-P260	1009108
WT45-N250	1009116
WT45-N260	1009109

 **Scanning distance**
400 ... 2000 mm

Photoelectric proximity switches

- Universal voltage
- Robust metal housing
- Infrared light, very long scanning range
- Adjustable background suppression
- Front lens heating, optional

Dimensional drawing

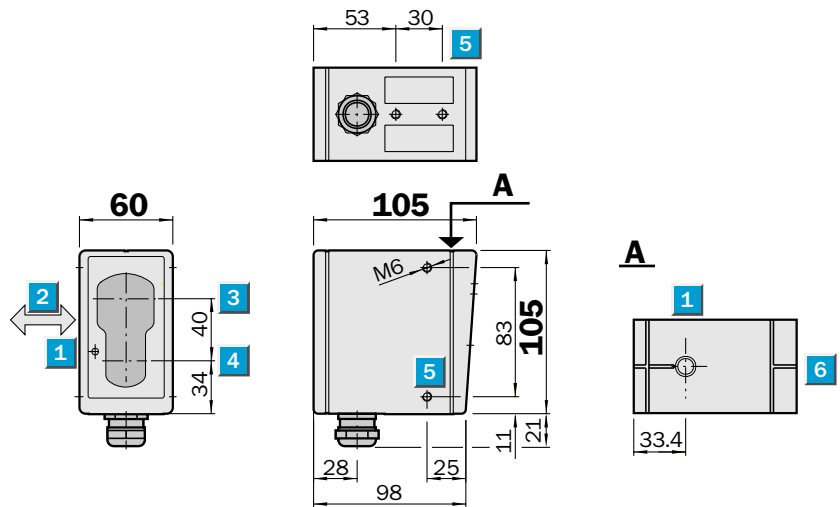

Adjustments possible

WT45-R250

WT45-R260

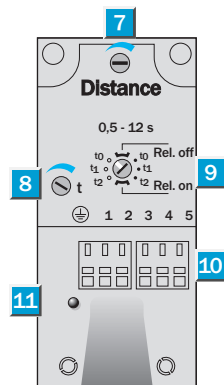

- 1 LED signal strength indicator
- 2 Standard direction of the material being scanned
- 3 Centre of optical axis, receiver
- 4 Centre of optical axis, sender
- 5 M6 threaded mounting hole – 8 mm deep
- 6 Alignment sight
- 7 Scanning distance adjustment
- 8 Time adjustment
- 9 Time delay selector switch
left: light-switching, right: dark-switching
- 10 Terminal strip
- 11 Status indicator

Switch-selectable time delay

0.5 – 12 s

t₀ without time delay

t₁ ON-delay when object enters detection zone

t₂ OFF-delay when object leaves detection zone

Connection type

WT45-R250

WT45-R260

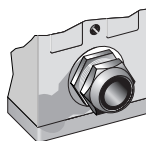

PG 13.5; terminals

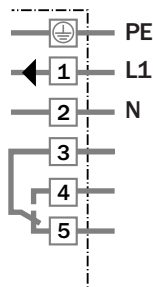

See chapter Accessories

Mounting systems

Special accessories

Technical data		WT45-	R250	R260								
Scanning distance	400...2000 mm, adjustable											
Light source¹⁾, light type	LED, infrared light											
Light spot diameter	Approx. 35 mm at 2000 mm											
Supply voltage V_S	24...240 V UC (+ 10%, - 25%)											
Power consumption	≤ 3 VA											
	≤ 6 VA, front lens heating											
Switching outputs	Relay, SPDT, isolated ²⁾											
Max. switching voltage	AC: 250 V / DC: 120 V											
Switching current	4 A / 240 V AC o. 24 V DC ³⁾											
Max. switching capacity	AC: 1000 VA / DC: 100 W											
Response time	≤ 20 ms											
Max. switching frequency ⁴⁾	10/s											
Connection type	Terminal connection											
VDE protection class	⊕											
Circuit protection⁵⁾	A, C											
Enclosure rating	IP 67											
Ambient temperature T_A	Operation - 25 °C...+ 55 °C ⁶⁾											
	Storage - 40 °C...+ 70 °C											
Weight	Approx. 800 g											
Front lens heating												
Housing material	Metal housing											

¹⁾ Average service life 100,000 h at $T_A = + 25 °C$

²⁾ Provide suitable spark suppression for inductive or capacitive loads

³⁾ Usage Category to EN 60947-1, 15 AC, 13 DC

⁴⁾ With light/dark ratio 1:1

⁵⁾ A = V_S connections reverse-polarity protected
C = Interference pulse suppression

⁶⁾ Up to 140 °C with cooling plates (see Accessories)

Scanning distance

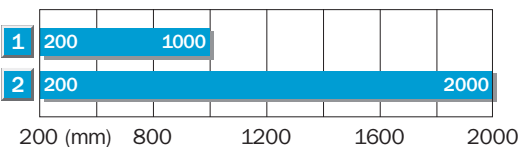

- 1 Scanning distance on black, 6% remission
- 2 Scanning distance on grey, 18% remission

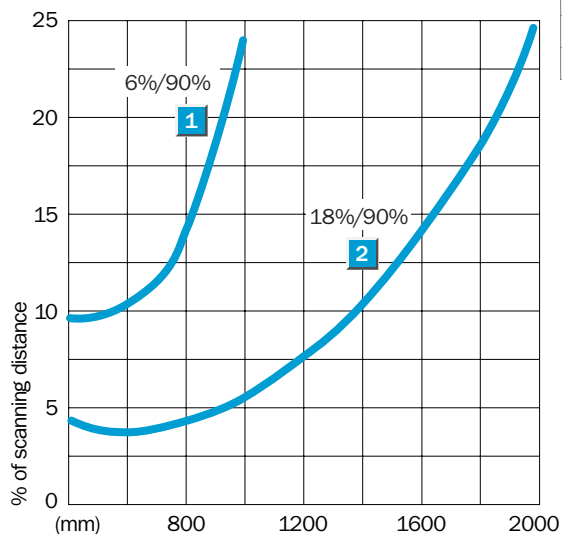

Order information

Type	Order no.
WT45-R250	1009118
WT45-R260	1009107

Scanning range
0.01 ... 55 m
 Photoelectric reflex switches

- Robust metal housing
- Red light
- Adjustable sensitivity
- Front lens heating, optional
- Pre-failure signalling output

Dimensional drawing

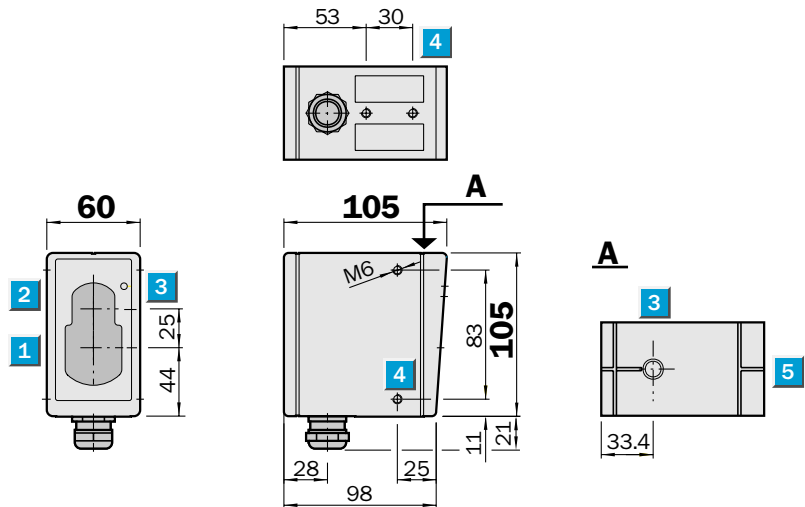

Adjustments possible

- WL45-P250
- WL45-P260
- WL45-N250
- WL45-N260

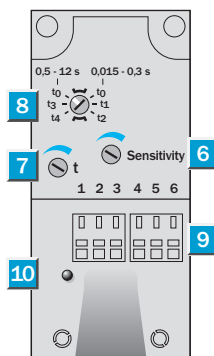

- 1 Centre of optical axis, sender
- 2 Centre of optical axis, receiver
- 3 LED signal strength indicator
- 4 M6 threaded mounting hole – 8 mm deep
- 5 Alignment sight
- 6 Sensitivity adjustment
- 7 Time adjustment
- 8 Time delay selector switch
- 9 Terminal strip
- 10 Status indicator

Switch-selectable time delay

0.5 – 12 s

- t_0 without time delay
- t_3 ON-delay when object enters detection zone
- t_4 OFF-delay when object leaves detection zone

0.015 – 0.3 s

- t_0 without time delay
- t_1 ON-delay when object enters detection zone
- t_2 OFF-delay when object leaves detection zone

Connection type

- WL45-P250
- WL45-P260
- WL45-N250
- WL45-N260

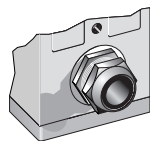

PG 13.5; terminals

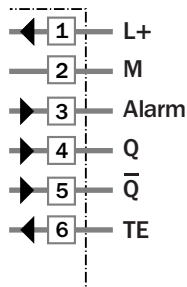

See chapter Accessories

- Mounting systems
- Reflectors
- Special accessories

Technical data		WL45-	P250	P260	N250	N260						
Scanning range , max. typical/on refl.	0.01...55 m/OP 60											
Sensitivity	Adjustable											
Light source¹⁾, light type	LED, visible red light											
Light spot diameter	Approx. 230 mm at 16 m											
Supply voltage V_S	10...60 V DC ²⁾											
Residual ripple ³⁾	< 5 V_{SS}											
Current consumption ⁴⁾	≤ 50 mA											
	≤ 250 mA, front lens heating											
Switching outputs	PNP, Q and \bar{Q}											
	NPN, Q and \bar{Q}											
Output current I_A max.	200 mA											
Response time ⁵⁾	≤ 1.2 ms											
Max. switching frequency ⁶⁾	400/s											
Pre-failure signalling output	Alarm											
Output current I_A max.	100 mA, open collector											
Insufficient light received	Flashes at approx. 5/s, switch to V_S											
(Reserve < 50 %)												
Test input »TE«												
Sender OFF	PNP: Test input to 0 V											
	NPN: Test input to V_S											
Connection type	Terminal connection											
VDE protection class⁷⁾	⊕											
Circuit protection⁸⁾	A, B, C											
Enclosure rating	IP 67											
Ambient temperature T_A⁹⁾	Operation - 25 °C...+ 55 °C											
	Storage - 40 °C...+ 70 °C											
Weight	Approx. 800 g											
Front lens heating												
Polarising filter												
Housing material	Metal housing											

- 1) Average service life 100,000 h at $T_A = + 25 °C$
- 2) Limit values
- 3) May not exceed or fall short of V_S tolerances
- 4) Without load
- 5) Signal transit time with resistive load
- 6) With light/dark ratio 1:1
- 7) Reference voltage 50 V DC
- 8) A = V_S connections reverse-polarity protected
B = Output Q and \bar{Q} short-circuit protected
C = Interference pulse suppression
- 9) Up to 140 °C with cooling plates (see Accessories)

Scanning range and operating reserve

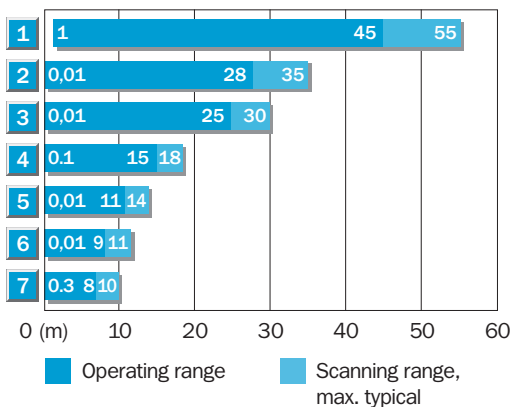

Reflector type	Operating range
1 OP 60 – ∞	1 ... 45 m
2 4 x PL 80	0,01 ... 28 m
3 PL 80 A	0,01 ... 25 m
4 C 110	0,1 ... 15 m
5 PL 50	0,01 ... 11 m
6 PL 30	0,01 ... 9 m
7 Reflective tape	0,3 ... 8 m
Diamond Grade	

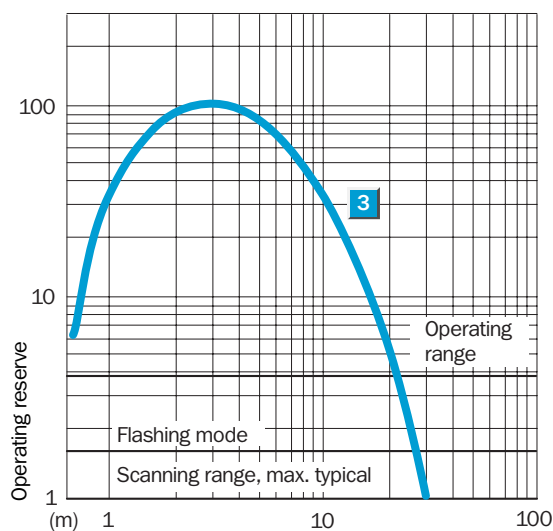

Order information

Type	Order no.
WL45-P250	1008840
WL45-P260	1008668
WL45-N250	1008839
WL45-N260	1008669

Scanning range
0.01 ... 55 m
 Photoelectric reflex switches

- Universal voltage
- Robust metal housing
- Red light
- Adjustable sensitivity
- Front lens heating, optional

Dimensional drawing

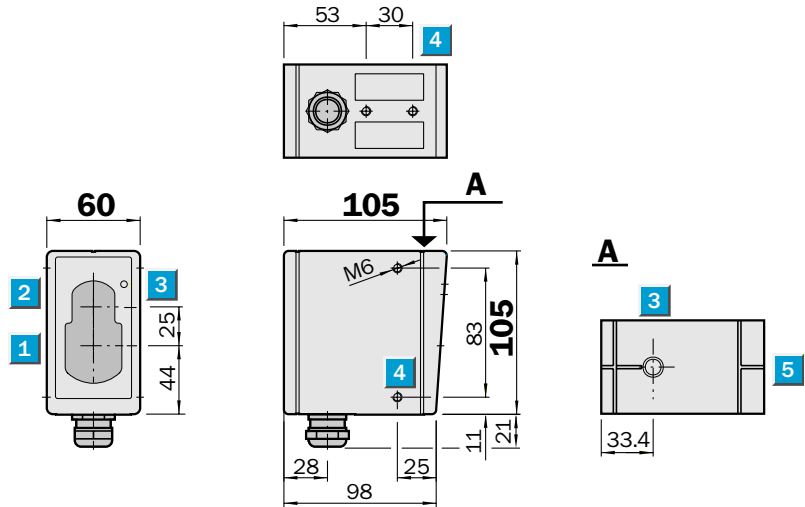

Adjustments possible

- WL45-R250
- WL45-R260

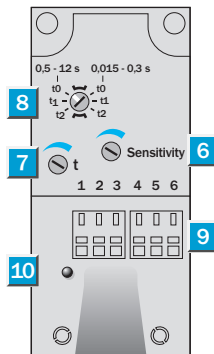

- 1 Centre of optical axis, sender
- 2 Centre of optical axis, receiver
- 3 LED signal strength indicator
- 4 M6 threaded mounting hole – 8 mm deep
- 5 Alignment sight
- 6 Sensitivity adjustment
- 7 Time adjustment
- 8 Time delay selector switch
left: light-switching, right: dark-switching
- 9 Terminal strip
- 10 Status indicator

Switch-selectable time delay

0.5 – 12 s

- t_0 without time delay
- t_1 ON-delay when object enters detection zone
- t_2 OFF-delay when object leaves detection zone

Connection type

- WL45-R250
- WL45-R260

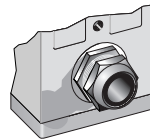

PG 13.5; terminals

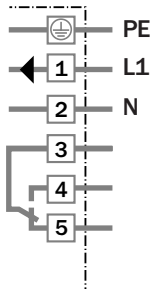

See chapter Accessories

- Mounting systems
- Reflectors
- Special accessories

Technical data		WL45-	R250	R260									
Scanning range , max. typ./on reflector	0.01...55 m/OP 60												
Sensitivity	Adjustable												
Light source¹⁾, light type	LED, visible red light												
Light spot diameter	Approx. 230 mm at 16 m												
Supply voltage V_S	24...240 V UC (+ 10 %, - 25 %)												
Power consumption	≤ 3 VA												
	≤ 6 VA, front lens heating												
Switching outputs	Relay, SPDT, isolated ²⁾												
Max. switching voltage	AC: 250 V / DC: 120 V												
Switching current	4 A / 240 V AC or 24 V DC ³⁾												
Max. switching capacity	AC: 1000 VA / DC: 100 W												
Response time	≤ 20 ms												
Max. switching frequency ⁴⁾	10/s												
Connection type	Terminal connection												
VDE protection class	⊕												
Circuit protection⁵⁾	A, C												
Enclosure rating	IP 67												
Ambient temperature T_A	Operation - 25 °C...+ 55 °C ⁶⁾												
	Storage - 40 °C...+ 70 °C												
Weight	Approx. 800 g												
Front lens heating													
Polarising filter													
Housing material	Metal housing												

- 1) Average service life 100,000 h at T_A = + 25 °C
 2) Provide suitable spark suppression for inductive or capacitive loads
 3) Usage Category to EN 60947-1, 15 AC, 13 DC
 4) With light/dark ratio 1:1
 5) A = V_S connections reverse-polarity protected
 C = Interference pulse suppression
 6) Up to 140 °C with cooling plates (see Accessories)

Scanning range and operating reserve		Order information	
Type	WL45-R250	Order no.	1008841
	WL45-R260		1008562

Reflector type	Operating range
1 OP 60 - ∞	1 ... 45 m
2 4 x PL 80	0,01 ... 28 m
3 PL 80 A	0,01 ... 25 m
4 C 110	0.1 ... 15 m
5 PL 50	0,01 ... 11 m
6 PL 30	0,01 ... 9 m
7 Reflective tape	0.3 ... 8 m
Diamond Grade	

Scanning range
0 ... 350 m

Through-beam photoelectric switches

- Robust metal housing
- Red light, very long range
- Adjustable sensitivity
- Front lens heating, optional
- Pre-failure signalling output

Dimensional drawing

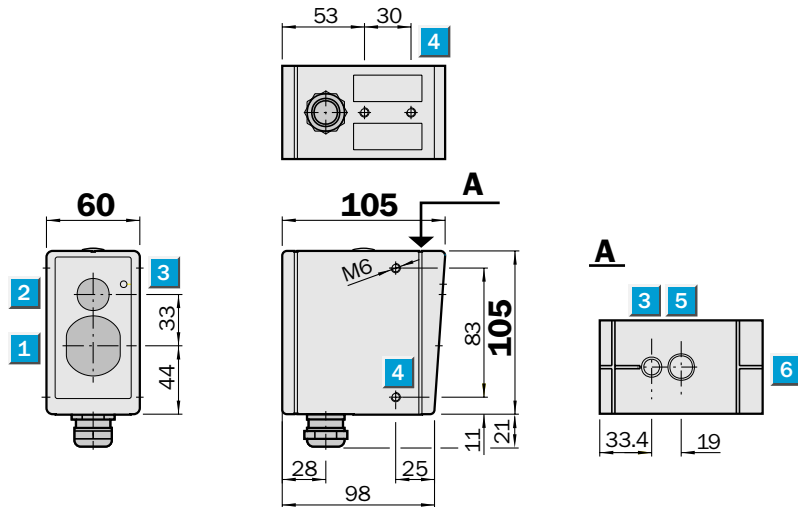

Adjustments possible

- WS/WE45-P250
- WS/WE45-P260
- WS/WE45-N250
- WS/WE45-N260

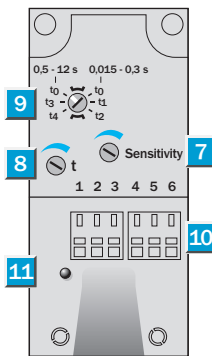

- 1 Centre of optical axis, sender (WS)
Centre of optical axis, receiver (WE)
- 2 View finder lens
- 3 LED signal strength indicator
- 4 M6 threaded mounting hole – 8 mm deep
- 5 Eyepiece for alignment aid
- 6 Alignment sight
- 7 Sensitivity adjustment
- 8 Time adjustment
- 9 Time delay selector switch
- 10 Terminal strip
- 11 Status indicator

Switch-selectable time delay

0.5 – 12 s

- t_0 without time delay
- t_3 ON-delay when object enters detection zone
- t_4 OFF-delay when object leaves detection zone

0.015 – 0.3 s

- t_0 without time delay
- t_1 ON-delay when object enters detection zone
- t_2 OFF-delay when object leaves detection zone

Connection type

- WS/WE45-P250
- WS/WE45-P260
- WS/WE45-N250
- WS/WE45-N260

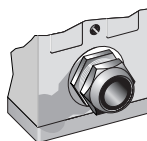

PG 13.5; terminals

Sender	Receiver
--------	----------

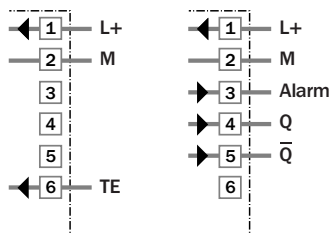

See chapter Accessories

- Mounting systems
- Special accessories

Technical data		WS/WE45-	P250	P260	N250	N260						
Scanning range, max. typical	0...350 m											
Sensitivity	Adjustable											
Light source¹⁾, light type	LED, infrared light											
Light spot diameter	Approx. 4.5 m at 300 m											
Angle of dispersion	Approx. 0.9°											
Supply voltage V_S	10...60 V DC ²⁾											
Residual ripple ³⁾	< 5 V _{SS}											
Current consumption ⁴⁾												
sender without heating	≤ 50 mA											
sender with heating	≤ 250 mA											
receiver without heating	≤ 50 mA											
receiver with heating	≤ 250 mA											
Switching outputs	PNP, Q and \bar{Q}											
	NPN, Q and \bar{Q}											
Output current I _A max.	200 mA											
Response time ⁵⁾	≤ 500 μs											
Max. switching frequency ⁶⁾	1000/s											
Pre-failure signalling output	Alarm											
Max. output current I _{Alarm}	100 mA, open collector											
Insufficient light received	Flashes at approx. 5/s, switch to V _S											
(Reserve < 50 %)												
Test input »TE«, sender OFF	PNP: Test input to 0 V											
Connection type	Terminal connection											
VDE protection class	⊕											
Circuit protection⁷⁾	A, B, C											
Enclosure rating	IP 67											
Ambient temperature T_A	Operation - 25 °C...+ 55 °C ⁸⁾											
	Storage - 40 °C...+ 70 °C											
Weight	Approx. 800 g											
Front lens heating												
Housing material	Metal housing											

- 1) Average service life 100,000 h at T_A = + 25 °C
- 2) Limit values
- 3) May not exceed or fall short of V_S tolerances

- 4) Without load
- 5) Signal transit time with resistive load
- 6) With light/dark ratio 1:1

- 7) A = V_S connections reverse-polarity protected
- B = Output Q and \bar{Q} short-circuit protected
- C = Interference pulse suppression

- 8) Up to 140 °C with cooling plates (see Accessories)

Scanning range and operating reserve

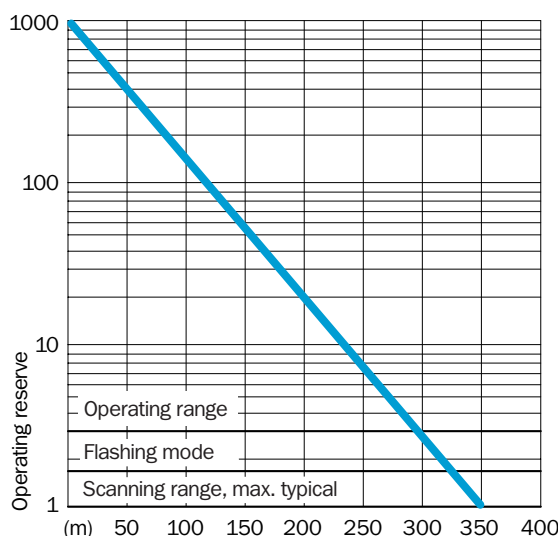
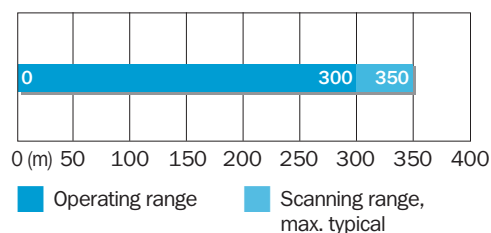

Order information

Type	Order no.
WS/WE45-P250	1010983
WS/WE45-P260	1010985
WS/WE45-N250	1010982
WS/WE45-N260	1010984

Scanning range
0 ... 350 m

Through-beam photoelectric switches

- Robust metal housing
- Red light, very long range
- Adjustable sensitivity
- Front lens heating, optional

Dimensional drawing

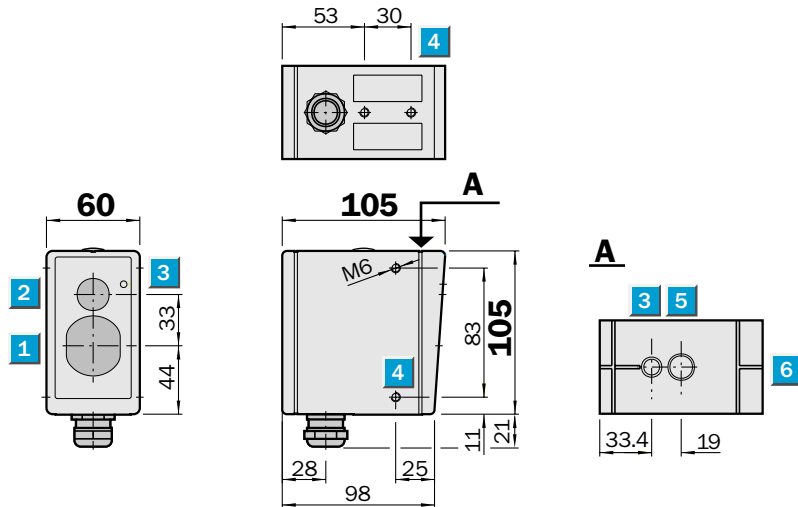

Adjustments possible

WS/WE45-R250

WS/WE45-R260

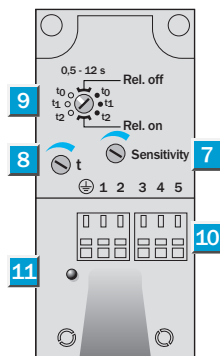

- 1 Centre of optical axis, sender (WS)
Centre of optical axis, receiver (WE)
- 2 View finder lens
- 3 LED signal strength indicator
- 4 M6 threaded mounting hole – 8 mm deep
- 5 Eyepiece for alignment aid
- 6 Alignment sight
- 7 Sensitivity adjustment
- 8 Time adjustment
- 9 Time delay selector switch
left: light-switching, right: dark-switching
- 10 Terminal strip
- 11 Status indicator

Switch-selectable time delay

0.5 – 12 s

t_0 without time delay

t_1 ON-delay when object enters detection zone

t_2 OFF-delay when object leaves detection zone



Connection type

WS/WE45-R250

WS/WE45-R260

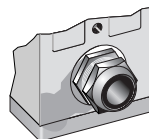

See chapter Accessories

Mounting systems

Special accessories

PG 13.5; terminals

Sender Receiver

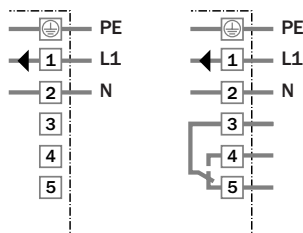

Technical data		WS/WE45-	R250	R260								
Scanning range, max. typical	0...350 m											
Sensitivity	Adjustable											
Light source¹⁾, light type	LED, infrared light, pulsating											
Light spot diameter	Approx. 4.5 m at 300 m											
Angle of dispersion	Approx. 0.9°											
Supply voltage V_S	24...240 V UC (+ 10 %, - 25 %)											
Power consumption												
sender without heating	≤ 3 VA											
sender with heating	≤ 6 VA											
receiver without heating	≤ 3 VA											
receiver with heating	≤ 6 VA											
Switching outputs	Relay, SPDT, isolated ²⁾											
Max. switching voltage	AC: 250 V / DC: 120 V											
Switching current	4 A / 240 V AC o. 24 V DC ³⁾											
Max. switching capacity	AC: 1000 VA / DC: 100 W											
Response time	≤ 10 ms											
Max. switching frequency ⁴⁾	10/s											
Connection type	Terminal connection											
VDE protection class	⊕											
Circuit protection⁵⁾	A, C											
Enclosure rating	IP 67											
Ambient temperature T_A	Operation - 25 °C...+ 55 °C ⁶⁾											
	Storage - 40 °C...+ 70 °C											
Weight	Approx. 800 g											
Front lens heating												
Housing material	Metal housing											

- 1) Average service life 100,000 h at T_A = + 25 °C
- 2) Provide suitable spark suppression for inductive or capacitive loads
- 3) Usage Category to EN 60947-1, 15 AC, 13 DC
- 4) With light/dark ratio 1:1
- 5) A = V_S connections reverse-polarity protected
C = Interference pulse suppression
- 6) Up to 140 °C with cooling plates (see Accessories)

Scanning range and operating reserve

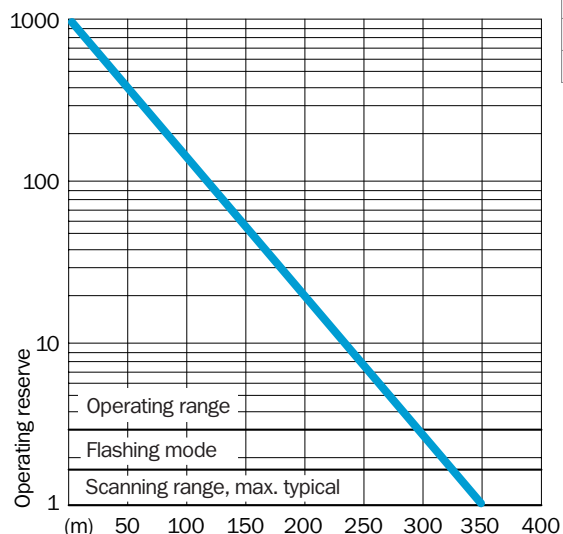
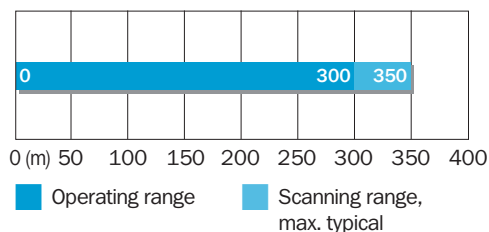

Order information

Type	Order no.
WS/WE45-R250	1010994
WS/WE45-R260	1010995