

Instruction Manual

E2M0.7, E2M1 and E2M1.5 Rotary Vacuum Pumps



Description		Item Number
E2M0.7 (0.7 m ³ h ⁻¹)	200-230 V, 50/60 Hz	A371-41-919
E2M0.7 (0.7 m ³ h ⁻¹)	100-120 V, 50/60 Hz	A371-41-902
E2M1.5 (1.5 m ³ h ⁻¹)	200-230 V, 50/60 Hz	A371-32-919
E2M1.5 (1.5 m ³ h ⁻¹)	200-230 V, 50/60 Hz (Interstage)	A371-04-919
E2M1.5 (1.5 m ³ h ⁻¹)	100-120 V, 50/60 Hz	A371-32-902
E2M1.5 (1.5 m ³ h ⁻¹)	100-120 V, 50/60 Hz (Interstage)	A371-04-902
E2M1 (1.0 ft ³ min ⁻¹)	200-230 V, 50/60 Hz	A372-33-919
E2M1 (1.0 ft ³ min ⁻¹)	100-120 V, 50/60 Hz	A372-33-902





Declaration of Conformity

We, Edwards Limited,
Crawley Business Quarter,
Manor Royal,
Crawley,
West Sussex, RH10 9LW, UK

declare under our sole responsibility, as manufacturer and person within the EU authorised to assemble the technical file, that the product(s)

E2M0.7 and E2M1.5 Rotary Vacuum Pumps with IEC connector

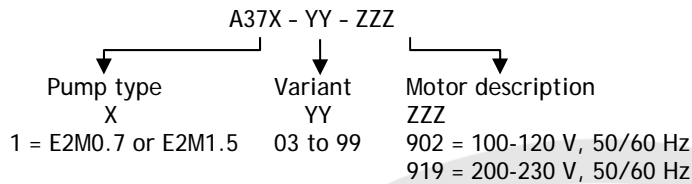

to which this declaration relates is in conformity with the following standard(s) or other normative document(s)

EN61010-1: 2010	Safety Requirements for Electrical Equipment for Measurement, Control and Laboratory Use. General Requirements
EN60034-1: 2010	Rotating electrical machines. Rating and performance
C22.2 No77: 1995	Motors with inherent overheating protection
C22.2 No100: 2004	Motors and Generators
C22.2 61010-1-04: 2004*	Safety requirements for electrical equipment for measurement. Control and laboratory use - Part 1: General requirements
UL61010A: 2002	Safety requirements for electrical equipment for measurement. Control and laboratory use - Part 1: General requirements
UL1004: 1994	Electric Motors
EN50581: 2012	Technical Documentation for the Assessment of Electrical and Electronic Products with respect to the Restriction of Hazardous Substances

* Only applicable to the IEC motor variant

and fulfils all the relevant provisions of

2006/42/EC	Machinery Directive
2006/95/EC	Low Voltage Directive
2004/108/EC	Electromagnetic Compatibility (EMC) Directive
2011/65/EU**	Restriction of Certain Hazardous Substances (RoHS) Directive

** i.e. The product(s) contain less than - 0.1wt% for hexavalent chromium, lead, mercury, PBB and PBDE; 0.01wt% for cadmium - in homogeneous materials (subject to the exemptions allowed by the Directive). The RoHS Directive does not legally apply to industrial vacuum equipment until July 2019 (July 2017 for instruments).

Note: This declaration covers all product serial numbers from the date this Declaration was signed onwards.

Peter Meares
GV Technical Support Manager

17.09.13, Burgess Hill

Date and Place

This product has been manufactured under a quality system certified to ISO9001:2008

P200-00-760 Issue F

Contents

Section	Page
1	Introduction 1
1.1	Scope and definitions 1
1.2	ATEX directive implications 2
1.3	Description 4
1.4	Gas-ballast 4
2	Technical data 5
2.1	Operating and storage conditions 5
2.2	Performance 5
2.3	Mechanical data 6
2.4	Electrical data 6
2.5	Lubrication data 7
3	Installation 9
3.1	Safety 9
3.2	System design 9
3.3	Unpack and inspect 10
3.4	Locate the pump 10
3.5	Fill the pump with oil 10
3.6	Electrical installation 10
3.6.1	Connect the pump to the electrical supply 11
3.6.2	Check the direction of rotation 11
3.7	Inlet-port connection 11
3.7.1	General requirements 11
3.7.2	Side inlet-port connection 12
3.8	Pump outlet connection 12
3.9	Leak-test the system 13
4	Operation 15
4.1	ATEX directive implications 15
4.1.1	Introduction 15
4.1.2	Flammable/pyrophoric materials 15
4.1.3	Gas purges 15
4.2	Gas-ballast control 16
4.3	Start-up procedure 16
4.4	To achieve ultimate vacuum 17
4.5	To pump condensable vapours 17
4.6	To decontaminate the oil 17
4.7	Unattended operation 18
4.8	Shut-down 18
5	Maintenance 19
5.1	Safety information 19
5.2	Maintenance plan 19
5.3	Check the oil-level 20
5.4	Replace the oil 20
5.5	Inspect and clean the inlet-filter 21
5.6	Clean or replace the gas-ballast O-ring 21
5.7	Clean the motor fan-cover and enclosure 22
5.8	Clean and overhaul the pump 22

5.9	Fit new blades	22
5.10	Replace the capacitor and test the motor	22
5.11	Fault finding	23
6	Storage and disposal	25
6.1	Storage	25
6.2	Disposal	25
7	Service, spares and accessories	27
7.1	Introduction	27
7.2	Service	27
7.3	Spares	27
7.4	Accessories	27
7.4.1	Inlet catchpot *	27
7.4.2	Inlet dust filter *	28
7.4.3	Inlet desiccant trap *	28
7.4.4	Inlet chemical trap *	28
7.4.5	Solenoid operated gas-ballast control valve	28
7.4.6	Foreline trap *	28
7.4.7	Solenoid operated pipeline valve *	28
7.4.8	Outlet mist filter	30
7.4.9	Oil drain extension	30
7.4.10	Vibration isolators	30
7.4.11	Pump inlet or outlet NW25 adaptor	30
	Index	31

Illustrations

Figure		Page
1	The E2M0.7, E2M1 and E2M1.5 pump	3
2	Dimensions (mm)	7
3	Inlet-filter removal and replacement	21
4	Gas-ballast O-ring removal and replacement	22
5	Accessories	29

Tables

Table	Page
1 Electrical data	6
2 Checklist of items	10
3 Wire colour codes	11
4 Maintenance plan	20
5 Fault finding	23

Associated publications

Publication title	Publication number
Vacuum Pump and Vacuum System Safety	P400-40-100

This page has been intentionally left blank.

1 Introduction

1.1 Scope and definitions

This manual provides installation, operation and maintenance instructions for the Edwards E2M0.7, E2M1 and E2M1.5 rotary vacuum pumps. The pump must be used as specified in this manual. Read this manual before installing and operating the pump.

Important safety information is highlighted as WARNING and CAUTION instructions that must be followed. The use of WARNINGS and CAUTIONS is defined below.



WARNING

Warnings are given where failure to observe the instruction could result in injury or death to people.

CAUTION

Cautions are given where failure to observe the instruction could result in damage to the equipment, associated equipment and process.

The units used throughout this manual conform to the SI international system of units of measurement.

The following warning symbols are on the pump:



Warning - refer to accompanying documentation.



Warning - risk of electric shock.



Warning - hot surfaces.

1.2 ATEX directive implications

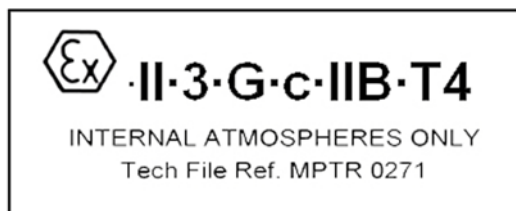

This equipment is designed to meet the requirements of Group II Category 3 equipment in accordance with Directive 94/9/EC of the European Parliament and the Council of 23rd March 1994 on the approximation of the laws of the Member States concerning equipment and protective systems intended for use in potentially explosive atmospheres. (The ATEX Directive)

The ATEX Category 3 applies in respect of potential ignition sources internal to the equipment. An ATEX Category has not been assigned in respect of potential ignition sources on the outside of the equipment as the equipment has not been designed for use where there is an external potentially explosive atmosphere.

There is no potential source of ignition within the pump during normal operation but there may be potential sources of ignition under conditions of predictable and rare malfunction as defined in the Directive. Accordingly, although the pump is designed to pump flammable materials and mixtures, operating procedures should ensure that under all normal and reasonably predictable conditions, these materials and mixtures are not within explosive limits. Category 3 is considered appropriate for the avoidance of ignition in the case of a rare malfunction which allows flammable materials or mixtures to pass through the pump while within their explosive limits.

When flammable or pyrophoric materials are present within the equipment:

- Do not allow air to enter the equipment.
- Ensure that the system is leak tight.

For further information, please contact Edwards: refer to the Addresses page at the end of this manual for details.

Figure 1 - The E2M0.7, E2M1 and E2M1.5 pump



CS/0218/A

- | | |
|--|---|
| 1. Outlet nozzle | 8. Removable side panel |
| 2. Oil filler-plug | 9. Baseplate |
| 3. Gas-ballast control | 10. Pump/motor shaft rotation direction arrow |
| 4. Handle (can be removed: see Section 3.4) | 11. Oil drain-plug |
| 5. Motor terminal box | 12. Pump identification label |
| 6. NW10 inlet-port (adaptor flange) | 13. Oil sight-glass and bezel |
| 7. Fan cover | |

1.3 Description

The Edwards E2M0.7, E2M1 and E2M1.5 pump is shown in [Figure 1](#). Refer to [Figure 1](#) for item numbers in brackets in the following descriptions.

The E2M0.7 and E2M1.5 pumps are two-stage, direct drive, sliding vane pumps. The pump is oil-sealed and designed for reliable, long-term operation. The pump is a free-standing unit. The drive is provided through an Oldham coupling by a single-phase motor.

The motor is totally enclosed and is cooled by the motor-cooling fan which directs air along the motor fins. The motor is fitted with a thermal overload device. When the motor is too hot, the thermal overload device switches off the pump. The thermal overload device has an automatic reset; when the motor cools down, the device resets and the motor will restart.

An oil pressure system lubricates the pump shaft bearing surfaces and rotor sealing faces. The pump has an oil distribution valve which prevents discharge of oil to the pump interior (suckback) after the pump stops. The pumping chambers are air-tight, so this arrangement prevents oil suckback unless the gas-ballast valve is open. For protection in this case, refer to [Section 1.4](#).

Inspect the level and condition of oil in the oil box reservoir through the sight-glass (13). An oil filler-plug (2) is fitted to the top of the oil box. An oil drain-plug (11) is fitted at the bottom of the oil box.

The pump has a carrying handle (4), inlet-port (6), outlet nozzle (1) and gas-ballast control (3). The pump is mounted on a steel baseplate (9) on rubber pads. Details of suitable vibration isolators and other recommended accessories are given in [Section 7](#).

1.4 Gas-ballast

To pump high vapour loads, gas-ballast is delivered into the pump to prevent condensation of the vapour carried by the pumped gases.

Air (or another gas) can be introduced into the low vacuum stage through the gas-ballast control. The gas-ballast control is a multi-turn valve which can be adjusted, as required, between closed and fully open.

2 Technical data

Note: To comply with EN61010 and CSA standards, the pump must be installed and used indoors, and within the operating conditions specified below.

2.1 Operating and storage conditions

Ambient temperature range (operation)	12 to 40°C (53.6 to 104°F)
Ambient temperature range (storage)	-30 to 70°C (-22 to 158°F)
Normal surface temperature of the pump-body*	50 to 70°C (122 to 158°F)
Maximum humidity (operation)	90% RH
Maximum altitude (operation)	2000 m (6561 ft)
Pollution degree	2
Installation category	II

* At ultimate vacuum, with ambient temperature of 20°C (68°F).

2.2 Performance

Note: Where total pressures are shown below, the measurements were taken using an untrapped total pressure capacitance diaphragm gauge on a header, as specified by Pneurop 6602.

	E2M0.7	E2M1	E2M1.5
Maximum displacement			
50 Hz electrical supply	0.9 m ³ h ⁻¹	1.0 ft ³ min ⁻¹	1.8 m ³ h ⁻¹
60 Hz electrical supply	1.1 m ³ h ⁻¹	1.3 ft ³ min ⁻¹	2.2 m ³ h ⁻¹
Maximum pumping speed - Pneurop			
50 Hz electrical supply	0.75 m ³ h ⁻¹	0.94 ft ³ h ⁻¹	1.6 m ³ h ⁻¹
60 Hz electrical supply	0.95 m ³ h ⁻¹	1.2 ft ³ h ⁻¹	2.0 m ³ h ⁻¹
Motor rotational speed			
50 Hz electrical supply	1400 r min ⁻¹	2800 r min ⁻¹	2800 r min ⁻¹
60 Hz electrical supply	1700 r min ⁻¹	3400 r min ⁻¹	3400 r min ⁻¹
Ultimate vacuum			
without gas-ballast (partial pressure)	7 x 10 ⁻⁴ mbar (7 x 10 ⁻² Pa)	3.8 x 10 ⁻⁴ torr (5 x 10 ⁻² Pa)	5 x 10 ⁻⁴ mbar (5 x 10 ⁻² Pa)
without gas-ballast (total pressure)	3 x 10 ⁻³ mbar (3 x 10 ⁻¹ Pa)	1.1 x 10 ⁻³ torr (1.5 x 10 ⁻¹ Pa)	1.5 x 10 ⁻³ mbar (1.5 x 10 ⁻¹ Pa)
with full gas-ballast (partial pressure)	2 x 10 ⁻¹ mbar (2 x 10 ⁻¹ Pa)	1.9 x 10 ⁻² torr (2.5 Pa)	2.5 x 10 ⁻² mbar (2.5 Pa)
Maximum water vapour inlet pressure	15 mbar	11.3 torr	15 mbar
Maximum water vapour pumping rate	8 g h ⁻¹	16 g h ⁻¹	16 g h ⁻¹
Maximum permitted outlet pressure (at full pump throughput)	0.5 bar gauge 1.5 bar absolute (1.5 x 10 ⁵ Pa)	0.5 bar gauge 1.5 bar absolute (1.5 x 10 ⁵ Pa)	0.5 bar gauge 1.5 bar absolute (1.5 x 10 ⁵ Pa)

2.3 Mechanical data

Approximate pump mass	10 kg (22 lbs)
Dimensions	See Figure 2
Degree of protection (IEC34-5:1981)	IP44
Pump inlet port	NW10 (the flange can be removed from the $\frac{3}{8}$ inch BSP tapped hole)
Pump outlet port	11 mm external diameter nozzle (the nozzle can be removed from the $\frac{3}{8}$ inch BSP tapped hole)
Noise level at 1 metre	54 dB(A)

2.4 Electrical data

The motor start-up current is drawn for less than one second. Use slow-blow fuses to prevent unnecessary fuse failure when the pump starts. If the pump is used at temperatures lower than 12 °C (53.6 °F), the start-up current will be drawn for longer; this may cause the motor thermal overload device to open.

E2M0.7 pump	
Motor output rating - continuous	0.09 kW
Motor electrical supply	Single phase
E2M1 and E2M1.5 pumps	
Motor output rating - continuous	0.16 kW
Motor electrical supply	Single phase

Table 1 - Electrical data

Pump	Nominal supply (V)	Frequency (Hz)	Full load current (A)	Start-up current (A)	Maximum fuse rating (A)*
E2M0.7	100-115	50	1.8	5.7	10
	100-120	60	1.9	5.3	10
	200-230	50	0.85	2.8	6
	200-240	60	1.0	2.3	6
E2M1 and E2M1.5	100-115	50	3.1	12.0	10
	100-120	60	3.0	11.2	10
	200-230	50	1.3	5.5	6
	200-230	60	1.4	5.2	6

* Fuses should be EN60269 [Section 2.2](#) or to BS 1362.

2.5 Lubrication data

Note: A Material Safety Data Sheet for Ultragrade 15 is available on request.

Recommended oil *	Ultragrade 15
Maximum oil capacity	0.32 litre

* To operate the pump when the ambient temperature is outside the range specified in Section 2.1, or to optimise pump performance when processing condensible vapours, a different oil may be required.

Figure 2 - Dimensions (mm)

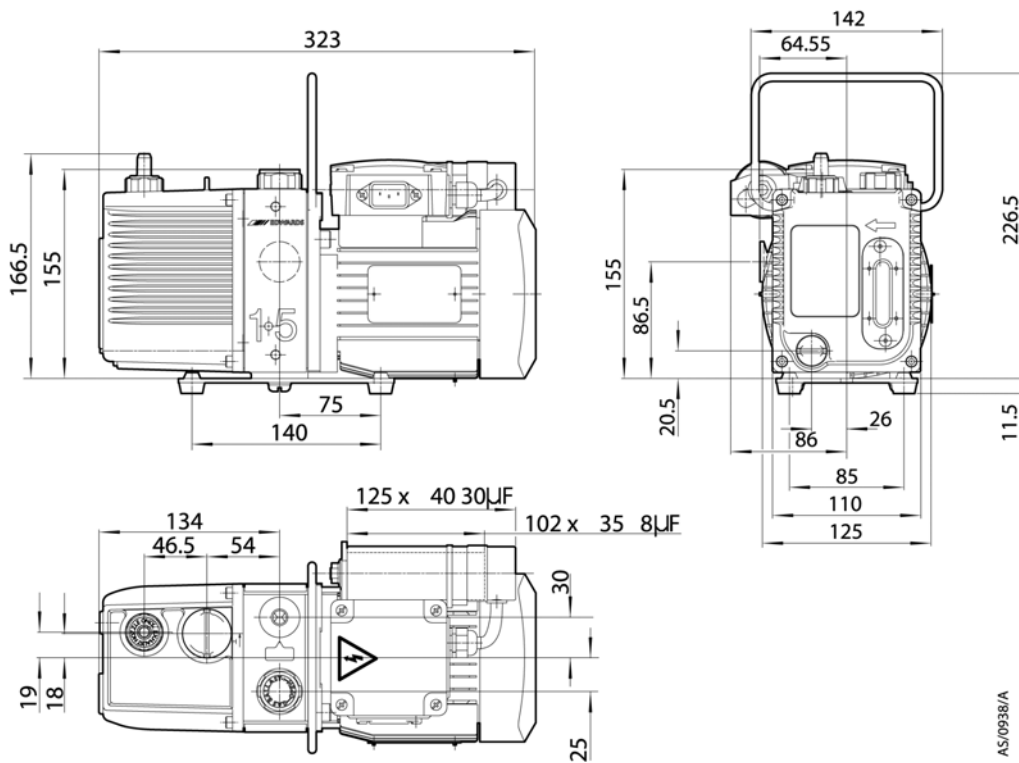

This page has been intentionally left blank.

3 Installation

3.1 Safety



WARNING

If a hydrocarbon oil is used in this pump, do not use the pump to process oxygen in concentrations greater than 25% in volume. If the oxygen concentration is greater than 25%, there is a risk of fire or explosion in the oil-box of the pump.



WARNING

Edwards recommends that the E2M0.7, E2M1 or E2M1.5 pumps are not used to pump hazardous substances.

Obey the safety instructions in this Section and take note of appropriate precautions. If not, injury to people and damage to equipment can result.

Prevent any part of the human body from coming into contact with the vacuum.

Ensure that the pump is suitable for your application. If there is any doubt as to the suitability of the pump for your application, refer to the Edwards guidelines on vacuum pump and vacuum system safety (see the Associated Publication at the end of the contents list at the front of this manual).

A suitably trained and supervised technician must install the pump. Obey the safety instructions listed below when installing the pump, especially when connecting the pump into an existing system. Details of specific safety precautions are given at the appropriate point in the instructions.

- Wear the appropriate safety-clothing when coming into contact with contaminated components.
- Vent and purge the vacuum system before starting installation work.
- Ensure that the installation technician is familiar with the safety procedures which relate to the pump-oil and the products handled by the pumping system. Take suitable precautions to avoid the inhalation of oil mist and excessive skin contact with pump-oil, as prolonged exposure can be harmful.
- Disconnect the other components in the pumping system from the electrical supply so that they cannot be operated accidentally.
- Safely route any electrical cables so that they cannot accidentally trip people.

3.2 System design

Consider the following points when designing the pumping system:

- Use a suitable valve to isolate the pump from the vacuum system to allow the pump to warm up before pumping condensable vapours or to maintain vacuum when the pump is switched off.
- Avoid high levels of heat input to the pump from the process gases, otherwise the pump may overheat and seize, and cause the motor thermal overload device to open.
- If the pump is used in a high ambient temperature and has a high gas throughput, the temperature of the pump-body may exceed 70°C (158°F). Fit suitable guards to prevent contact with hot surfaces.
- Make sure that the exhaust pipeline cannot become blocked. If the system has an exhaust-isolation valve, make sure that the pump cannot operate with the valve closed.
- Provide for a purge of inert gas when shutting down the pumping system, to dilute dangerous gases to safe concentrations. A suitable gas-ballast control valve for introduction of purge gas into the pump is available as an accessory (see [Section 7.4.5](#)).

3.3 Unpack and inspect

Remove all packing materials and protective covers and check the pump. If the pump is damaged, notify your supplier and the carrier in writing within three days; state the Item Number of the pump together with your order number and your supplier's invoice number. Retain all packing materials for inspection. Do not use the pump if it is damaged.

Check that your package contains the items listed in [Table 2](#). If any of these items is missing, notify your supplier within three days.

If the pump is not to be used immediately, replace the protective covers. Store the pump in suitable conditions, as described in [Section 6](#).

Table 2 - Checklist of items

Qty	Description	Check (✓)
1	Rotary vacuum pump	<input type="checkbox"/>
	Fitting pack containing the following:	
1	Hexagon wrench, 4mm	<input type="checkbox"/>
1	Hexagon wrench, 6mm	<input type="checkbox"/>
1	NW10 centring ring	<input type="checkbox"/>
1	O-ring for centring	<input type="checkbox"/>
1	O-ring for outlet port	<input type="checkbox"/>

3.4 Locate the pump

The pump can be either free-standing on its baseplate which is fitted with rubber pads; fixed by four fixing bolt holes in the baseplate; or used with vibration isolators. For the location of fixing holes in the baseplate, refer to [Figure 2](#). Provide a firm, level platform for the pump. Locate the pump so that the oil level sight-glass is visible and the oil filler-plug, oil drain-plug, mode selector and gas-ballast control are accessible.

If the pump is part of a permanent installation the handle can be removed to make the pump more compact. To remove the handle, cut the handle into two and remove the free portions from the pump.

If the pump will be located inside an enclosure, ensure that there is adequate ventilation at both ends of the pump, so that the ambient temperature around the pump does not exceed 40°C. There must be a minimum space of 25 mm between the pump and enclosure walls.

3.5 Fill the pump with oil

Fill the pump with oil as described below. Refer to [Figure 1](#) for the item numbers in brackets.

1. Remove the oil filler-plug (10).
2. Pour oil into the pump until the oil-level just reaches the MAX mark on the bezel at the top of the sight-glass (5). If the oil-level goes above the MAX mark, remove the drain-plug (6) and drain the excess oil from the pump.
3. After a few minutes, recheck the oil-level. If the oil-level is now below the MAX mark, pour more oil into the pump.
4. Refit the oil filler-plug. Tighten the plug firmly by hand. Do not overtighten.

3.6 Electrical installation



WARNING

Ensure that the electrical installation of the pump conforms with your local and national safety requirements. It must be connected to a suitably fused and protected electrical supply and a suitable earth (ground) point.

3.6.1 Connect the pump to the electrical supply

Note: The pump will restart automatically when the electrical supply is restored after an interruption and when the pump cools after it has overheated. If automatic pump restart is not required, use electric control equipment that must be reset manually.

Make the electrical connections to the pump motor with an IEC 320 cable socket (cold condition type) that satisfies your local electrical standards. A range of suitable cables are available from your supplier or Edwards.

The pump must be connected to a suitable fused and protected electrical supply and suitable earth point.

If the EM pump was supplied with an electrical supply cable, the cable will be fitted with a moulded IEC 10 amp connector at one end. The other end of the cable may be fitted with a plug suitable for your local electrical supply. A cable without a plug will contain wires colour coded as follows:

Table 3 - Wire colour codes

Convention	Earth	Neutral	Live
Europe	green and yellow	blue	brown
USA	green	white	black

1. Insert the moulded IEC connector at the end of the cable into the electrical inlet connector on the motor.
2. Connect the plug (if fitted) at the other end of the cable to the electrical supply. If a plug is not fitted, connect the wires in the cable to the correct terminals of the electrical supply.

3.6.2 Check the direction of rotation

CAUTION

Ensure that the pump-motor rotates in the correct direction. If it does not, the pump and the vacuum system can become pressurised.

Refer to [Figure 1](#).

1. Watch the motor-cooling fan through the fan cover (7) on the end of the motor.
2. Switch on the electrical supply to the motor for a few seconds.
3. Check that the motor-cooling fan rotates in the direction shown by the arrow (8) on the end of the oil box. If the rotation direction is incorrect, immediately switch off the electrical supply and contact your supplier or Edwards for advice.

3.7 Inlet-port connection

3.7.1 General requirements

To connect the pump to the vacuum system, use either the inlet-port on the top of the pump ([Figure 1](#), item 11) or the inlet-port on the side of the pump (not shown). To use the side inlet-port, refer to the procedure in [Section 3.7.2](#).

When using the top or the side inlet-port:

- Connect to the NW10 flange supplied on the pump; use the centring ring and O-ring supplied.
- Remove the NW10 flange and connect to the 3/8 inch BSP threaded hole.
- Remove the NW10 flange and replace it with a NW25 flange adaptor (available as an optional accessory, see [Section 7](#)) and then connect to the NW25 flange.

Take note of the following information when connecting the pump to the vacuum system. Refer to [Section 7](#) for details of the accessories mentioned below.

- For optimum pumping speeds, ensure that the pipeline connected to the inlet-port is as short as possible and has an internal diameter not less than the inlet-port diameter.
- Support the vacuum pipelines to prevent loading of the coupling-joints.
- If necessary, incorporate flexible bellows in the system pipelines to reduce the transmission of vibration and to prevent loading of coupling-joints. If using flexible bellows, ensure that the bellows which have a maximum pressure rating which is greater than the highest pressure that can be generated in the system. Edwards recommends using Edwards flexible bellows.
- Use a suitable inlet-filter if pumping condensable vapours or if using the pump for very dusty applications.
- Use a suitable valve to isolate the pump from the vacuum system when pumping condensable vapours or to maintain vacuum when the pump is switched off.
- Ensure that sealing surfaces are clean and scratch-free.

3.7.2 Side inlet-port connection

A side inlet-port is available, refer to [Figure 1](#). To use the side inlet-port, use the following procedure.

1. Carefully remove the side panel (3) from the pump: use a suitable flat blade screwdriver or similar tool for this purpose. The panel is located by two nylon rivets.
2. Unscrew and remove the blanking plug with its O-ring.
3. Unscrew and remove the adaptor flange (11) and its O-ring and replace it with the blanking plug and O-ring that was removed in Step 2.
4. Screw the adaptor flange (11) and its O-ring into the side inlet-port.

3.8 Pump outlet connection



WARNING

Connect the pump outlet to a suitable treatment plant to prevent the discharge of dangerous gases and vapours to the surrounding atmosphere. Use a catchpot to prevent the drainage of contaminated condensate back into the pump.

To connect the pump to your outlet accessories or to the exhaust treatment plant:

- Connect a 10 mm internal diameter vacuum hose or 12 mm internal diameter plastic hose to the outlet nozzle ([Figure 1](#), item 9).
- Remove the outlet nozzle and connect to the 3/8 inch BSP tapped hole.
- Remove the outlet nozzle and replace it with an NW25 flange adaptor (available as an optional accessory, see [Section 7](#)) and then connect to the NW25 flange.

Take note of the following information before connecting to the pump outlet:

- The exhaust system must be configured so that the maximum pressure at the pump outlet does not exceed 0.5 bar gauge (1.5 bar absolute, 1.5×10^5 Pa) at full pump throughput.
- In the following circumstances, Edwards recommends fitting an oil mist filter to the pump outlet
 - if using the pump with the gas-ballast control open

- if operating the pump with an inlet pressure greater than 10 mbar for extended periods or
- if frequently pumping down from atmospheric pressure.
- The mist filter will trap the oil exhausted from the pump: the oil can be re-used if it is not contaminated.

3.9 Leak-test the system

Leak-test the system and seal any leaks found, after installing the pump, to prevent leakage of substances out of the system and leakage of air into the system.

This page has been intentionally left blank.

4 Operation

4.1 ATEX directive implications

4.1.1 Introduction

This equipment is designed to meet the requirements of Group II Category 3 equipment in accordance with Directive 94/9/EC of the European Parliament and the Council of 23rd March 1994 on the approximation of the laws of the Member States concerning equipment and protective systems intended for use in potentially explosive atmospheres. (The ATEX Directive)

The ATEX Category 3 applies in respect of potential ignition sources internal to the equipment. An ATEX Category has not been assigned in respect of potential ignition sources on the outside of the equipment as the equipment has not been designed for use where there is an external potentially explosive atmosphere.

There is no potential source of ignition within the pump during normal operation but there may be potential sources of ignition under conditions of predictable and rare malfunction as defined in the Directive. Accordingly, although the pump is designed to pump flammable materials and mixtures, operating procedures should ensure that under all normal and reasonably predictable conditions, these materials and mixtures are not within explosive limits. Category 3 is considered appropriate for the avoidance of ignition in the case of a rare malfunction which allows flammable materials or mixtures to pass through the pump whilst within their explosive limits.

4.1.2 Flammable/pyrophoric materials

When flammable or pyrophoric materials are present within the equipment:



WARNING

Obey the instructions and take note of the precautions given below, to ensure that pumped gases do not enter their flammable ranges.

- Do not allow air to enter the equipment.
- Ensure that the system is leak tight.
- Use an inert gas purge (for example, a nitrogen purge) to dilute any flammable gases or vapours entering the pump inlet, and/or use an inert gas purge to reduce the concentration of flammable gases or vapours in the pump and in the exhaust pipeline to less than one quarter of the gases' published lower explosive limits (LEL).
- Use an inert gas purge in to the pump gas ballast connection to prevent the condensation of flammable vapours within the pump mechanism and exhaust pipeline.

4.1.3 Gas purges



WARNING

If using inert gas purges to dilute dangerous gases to a safe level, ensure that the pump is shut down if an inert gas supply fails.



WARNING

Obey the instructions and take note of the precautions given below, to ensure that pumped gases do not enter their flammable ranges.

Switch on the inert gas purge to remove air from the pump and the exhaust pipeline before the process starts. Switch off the purge flow at the end of the process only after any remaining flammable gases or vapours have been purged from the pump and exhaust pipeline.

If liquids that produce flammable vapours could be present in the pump foreline, then the inert gas purge to the pump should be left on all the time this liquid is present. Flammable liquids could be present in the foreline as a result of condensation, or may be carried over from the process.

When calculating the flow rate of inert gas required for dilution, consider the maximum flow rate for the flammable gases/vapours that could occur. For example, if a mass flow controller is used to supply flammable gases to the process, assume a flow rate for flammable gases that could arise if the mass flow controller is fully open.

Continually measure the inert gas purge flow rate: if the flow rate falls below that required, you must stop the flow of flammable gases or vapours into the pump.

Note: Edwards recommends obtaining and reading the *Vacuum Pump and Vacuum System Safety manual* (publication number P400-40-100), available from Edwards or your supplier.

4.2 Gas-ballast control

Use the gas-ballast control (Figure 1, item 2) to change the amount of air (or inert gas) introduced into the low vacuum stage of the pump. Use of the gas-ballast will prevent the condensation of vapours in the pump; the condensates would contaminate the oil.

Use the gas-ballast control closed:

- to achieve ultimate vacuum
- to pump dry gases.

Turn the gas-ballast control six turns anti-clockwise to open it fully. Use the gas-ballast control open:

- to pump high concentrations of condensable vapour
- to decontaminate the oil.

When operating the pump with the gas-ballast control open, there will be an increased rate of oil loss from the pump.

4.3 Start-up procedure



WARNING

Ensure that the system design does not allow the exhaust pipeline to be blocked.

If the oil is contaminated, or if the pump temperature is below 12°C (53.6°F), or if the electrical supply voltage is more than 10% below the lowest voltage specified for the pump, the pump may operate at a reduced speed for a few minutes. If the pump continues to operate at reduced speed, the motor thermal overload device will open and stop the pump. When the motor has cooled, the thermal overload device will reset automatically and the pump will restart.

1. Check that the pump oil-level is between the MAX and MIN marks on the bezel of the oil-level sight-glass; if it is not, refer to [Section 5.3](#).
2. Turn the gas-ballast control to the required position (refer to [Section 4.2](#)).
3. Switch on the electrical supply to the pump.
4. Check that the oil-level in the sight-glass drops slightly (3 to 5 mm) after start-up. This shows that the pump has primed with oil.

5. If the pump fails to prime, operate the pump with the inlet open to atmosphere for approximately 30 seconds. Then isolate the inlet and check that the oil-level drops by 3 to 5 mm.
6. To achieve ultimate vacuum, pump condensable vapours or decontaminate the pump oil, refer to the procedures in Sections 4.4, 4.5 and 4.6 respectively. Otherwise, open the vacuum system isolation-valve.

4.4 To achieve ultimate vacuum

If the pump does not achieve the performance specified in [Section 2](#), make sure that this is not due to the vacuum system design before contacting your supplier or Edwards for advice. In particular, the vapour pressure of all materials used in the vacuum system (including pump oil, see below) must be much lower than the specified ultimate vacuum of the pump. Refer to [Table 5](#) for a list of possible causes for failure to achieve the specified performance; note however that the most common causes are:

- The pressure measurement technique or gauge head is unsuitable or the gauge head is faulty.
- An oil other than the recommended oil has been used, and the vapour pressure of the oil is higher than the specified ultimate vacuum of the pump.

Use the following procedure to achieve ultimate vacuum:

1. Isolate the pump from the vacuum system.
2. Turn the gas-ballast control fully anti-clockwise (fully open) and operate the pump for at least 1 hour (or overnight) to thoroughly purge the oil of contaminants.
3. Close the gas-ballast control.
4. Open the vacuum system isolation-valve and pump down to ultimate vacuum.

4.5 To pump condensable vapours

Use gas-ballast (open the gas-ballast control) when there is a high proportion of condensable vapours in the process gases.

1. Close the vacuum system isolation-valve.
2. Turn the gas-ballast control anti-clockwise to fully open and operate the pump for 30 minutes to warm the oil; this will help to prevent vapour condensation in the pump.
3. Open the vacuum system isolation-valve and continue to operate the pump with the gas-ballast control open.

After pumping condensable vapours, decontaminate the oil (if necessary); use the procedure in [Section 4.6](#).

4.6 To decontaminate the oil

The oil in the pump should be clear, if the oil is cloudy or discoloured, it is contaminated with process vapours.

1. Look at the condition of the oil in the oil sight-glass ([Figure 1](#), item 7). If the oil is cloudy or discoloured, continue with the procedure at Step 2 below.
2. Close the vacuum system isolation-valve.
3. Turn the gas-ballast control fully anti-clockwise.
4. Operate the pump until the oil is clear.

4.7 Unattended operation

The pump is designed for unattended operation under the normal operating conditions specified in [Section 2](#). However, Edwards recommends checking the pump at a regular interval of not more than 14 days; check the pump more frequently if pumping high volumes of gas or if operating the pump with the gas-ballast control open.

The motor is protected by an overload device which isolates the pump from the electrical supply when critical temperature or current levels are exceeded. The overload device resets automatically when the motor has cooled. When checking the pump, make sure that the pump is not going through a repetitive cycle of thermal overload failures and automatic resets. If necessary reduce the thermal load from the pumped gases, to prevent overheating of the pump.

4.8 Shut-down

Note: If the gas-ballast control is open and the motor is switched off for any reason, the pump drive shaft may rotate in the reverse direction, causing a system pressure rise. To prevent this, use a gas-ballast control valve (refer to [Section 7.4.5](#)).

Edwards recommends, as described in the procedure below, decontaminating the oil before shutting down the pump; this will prevent damage to the pump by the contaminants in the oil.

1. Refer to [Section 4.6](#) and decontaminate the oil, as required.
2. Close the vacuum system isolation-valve (if not already closed).
3. Close gas-ballast (that is, turn the gas-ballast control clockwise).
4. Switch off the electrical supply to the pump.

5 Maintenance

5.1 Safety information



WARNING

Obey the safety instructions given below and take note of appropriate precautions. Failure to follow the instructions can cause injury to people and damage to equipment.

- A suitably trained and supervised technician must maintain the pump. Obey your local and national safety requirements.
- Ensure that the maintenance technician is familiar with the safety procedures which relate to the pump-oil and the products processed by the pumping-system.
- Allow the pump to cool to a safe temperature before starting maintenance work.
- Isolate the pump and other components in the pumping system from the electrical supply so that they can not be operated accidentally.
- After maintenance is completed, recheck the pump rotation direction if the electrical supply has been disconnected.
- Do not reuse O-rings and seals if they are damaged.
- The pump and its fluid will be contaminated with the process chemicals that have been pumped during operation. Ensure that the pump is decontaminated before maintenance and that adequate precautions are taken to protect people from the effects of dangerous substances if contamination has occurred.
- Do not touch or inhale the thermal breakdown products of fluorinated materials which may be present if the pump has been heated to 260°C (500°F) and above. These breakdown products are very dangerous. Fluorinated materials in the pump may include oils, greases and seals. The pump may have overheated if it was misused, if it malfunctioned or if it was in a fire. Edwards Material Safety Data Sheets for fluorinated materials used in the pump are available on request: contact your supplier or Edwards.
- Leak-test the system after maintenance work is complete if any vacuum or exhaust joints were connected or disconnected; seal any leaks found.

5.2 Maintenance plan

The plan shown in [Table 4](#) details the routine maintenance operations necessary to maintain the pump in normal use. Instructions for each operation are given in the section shown.

More frequent maintenance may be required if the pump is used to process corrosive or abrasive gases and vapours; in these circumstances, Edwards recommends replacing the pump seals every year. If necessary, adjust the maintenance plan according to your experience.

When maintaining the pump, use Edwards spares and maintenance kits; these contain all of the components necessary to complete maintenance operations successfully. The Item Numbers of the spares and kits are given in [Section 7](#).

Examine the condition of any external accessories, filters or traps (if fitted). Refer to the instructions supplied with these accessories for maintenance procedure.

Table 4 - Maintenance plan

Operation	Frequency	Refer to Section
Check the oil-level	Monthly	5.3
Replace the oil	3000 operation hours	5.4
Inspect and clean the inlet-filter	Every oil change	5.5
Clean or replace the gas-ballast O-ring	Every oil change	5.6
Clean the motor fan-cover	Yearly	5.7
Clean and overhaul the pump	15000 operation hours	5.8
Fit new blades	30000 operation hours	5.9
Replace the capacitor	Every 4 years	5.10
Test the motor condition	Every 15000 hours of operation	5.10

5.3 Check the oil-level

Note: If required, the oil-level can be checked while the pump is operating, however the pump must be switched off and isolate the pump and other components in the pumping system from the electrical supply before pouring oil into the pump.

Refer to [Figure 1](#) for the items in brackets.

1. Check that the oil-level in the sight-glass (5) is between the MAX and MIN level marks on the bezel of the sight-glass.
2. If the oil-level is near to or below the MIN level mark, remove the filler-plug (10) and pour more oil into the reservoir until the oil reaches the MAX level mark. If the oil-level goes above the MAX mark, remove the drain-plug (6) and drain the excess oil from the pump. Refit the filler-plug.
3. If the oil is contaminated, drain and refill the pump with clean oil as described in [Section 5.4](#).

5.4 Replace the oil

Refer to [Figure 1](#) for the items in brackets.

1. Operate the pump for approximately ten minutes to warm the oil, then switch off the pump. (this lowers the viscosity of the oil and enables it to be drained from the pump more easily).
2. Isolate the pump from the electrical supply and disconnect it from the vacuum system.
3. Remove the oil filler-plug (10).
4. Place a suitable block under the pump-motor to tilt the pump and place a suitable container under the drain-plug (6). Remove the drain-plug and allow the oil to drain into the container.
5. If the oil is dirty or contaminated, pour clean oil into the pump and allow it to drain out of the pump. Repeat this step until the oil reservoir is clean.
6. Refit the drain-plug, remove the block and reconnect the pump to the vacuum system.
7. Fill a suitable container with clean oil and pour the oil into the filler hole until the oil-level reaches the MAX level mark on the bezel of the sight-glass (5).
8. Allow a few minutes for the oil to drain into the pump. If necessary, add more oil. Refit the filler-plug.

5.5 Inspect and clean the inlet-filter

1. Refer to [Figure 3](#). Unscrew the inlet adaptor (1) and remove the inlet-filter (2) and O-ring (3).
2. Wash the filter in a suitable cleaning solution. Allow the filter to dry.
3. Refit the O-ring (3), inlet-filter (2) and inlet adaptor (1).

Figure 3 - Inlet-filter removal and replacement

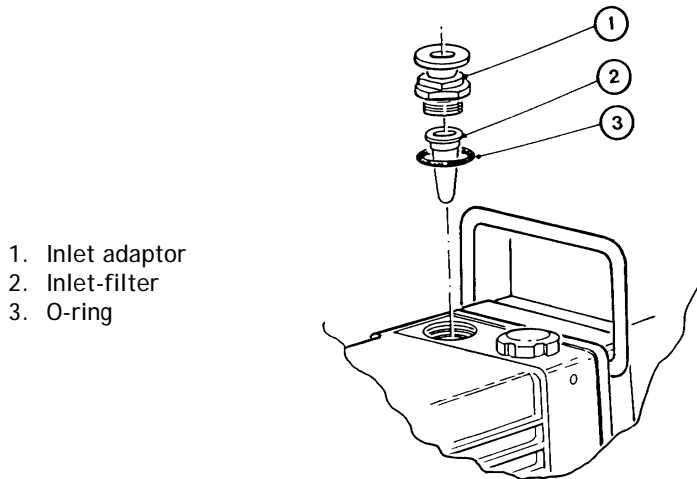

5.6 Clean or replace the gas-ballast O-ring

Note: The filter element (3) is retained in its seating with adhesive; do not try to remove it.

Refer to [Figure 4](#).

1. Unscrew and remove the gas-ballast control (1).
2. Remove the O-ring (2) from the control.
3. Wash the O-ring in a suitable cleaning solution. Replace the O-ring if it is damaged.
4. Replace the O-ring carefully on its seat. Screw the gas-ballast control back into the pump, and reset to the required position.

Figure 4 - Gas-ballast O-ring removal and replacement

1. Gas-ballast control
2. O-ring
3. Filter element

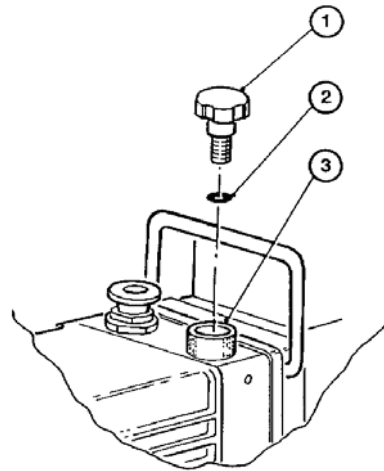

5.7 Clean the motor fan-cover and enclosure

If the motor fan-cover and enclosure are not kept clean, the air-flow over the motor can be restricted and the pump may overheat.

1. Switch off the pump and disconnect it from the electrical supply.
2. Use a dry cloth and a soft brush to remove dirt and deposits from the fan-cover and enclosure.

5.8 Clean and overhaul the pump

Clean and overhaul the pump as described in the instruction supplied with the clean and overhaul kit (see [Section 7](#)).

5.9 Fit new blades

Fit new blades to the pump as described in the instructions supplied with the blade kit (see [Section 7](#)).

5.10 Replace the capacitor and test the motor

Replace the capacitor as described in the instructions supplied with the capacitor kit.

Test the earth (ground) continuity and the insulation resistance of the pump motor, in accordance with local regulations for periodic testing of electrical equipment. Edwards recommends that:

- The earth (ground) continuity is less than 0.1 Ω .
- Insulation resistance is greater than 10 M Ω .

If the motor fails these tests, the motor must be replaced.

5.11 Fault finding

A list of fault conditions and their possible causes is provided here to assist in basic fault-finding. If unable to rectify a fault when using this guide, call your supplier or your nearest Edwards Service Centre for advice.

Table 5 - Fault finding

Fault condition	Possible cause
The pump has failed to start	<ul style="list-style-type: none"> The electrical supply fuse has blown. The motor is incorrectly wired. The operating voltage does not match that of the motor. The exhaust filter or exhaust line is blocked. The oil temperature is below 12°C (53.6°F). The oil is too viscous. The oil is contaminated. The pump is seized after long storage, or has been left to stand after pumping contaminants. The motor is faulty.
The pump failed to achieve specified performance (Failure to reach ultimate vacuum)	<ul style="list-style-type: none"> The measuring technique or gauge is unsuitable. There is a leak in the external vacuum system. The gas-ballast control is open. The oil level is too low. The pump is filled with the wrong type of oil. The oil is contaminated. The pump has not primed. The vacuum fittings are dirty. The inlet-filter is blocked. The pump has not warmed up.
The pump is noisy	<ul style="list-style-type: none"> The motor fan-cover is damaged. The motor bearings are worn. The oil is contaminated with solid particles. One of the pump blades is sticking.
The pump surface temperature is above 100°C (212°F)	<ul style="list-style-type: none"> The ambient temperature is too high. The cooling-air supply is insufficient or is too hot. The cooling-air supply is blocked. The electrical supply voltage is too high. The exhaust filter or exhaust line is blocked. The oil level is too low. The pump is filled with the wrong type of oil. The oil is contaminated. The process gas is too hot, or the throughput is too high.
The vacuum is not maintained after the pump is switched off	<ul style="list-style-type: none"> The gas-ballast control is open. O-ring(s) are damaged or missing. The shaft seals have deteriorated.

Table 5 - Fault finding (continued)

Fault condition	Possible cause
The pumping speed is poor	The connecting pipelines are too small in diameter. The connecting pipelines are too long. The inlet-filter is blocked.
There is an external oil leak	The oil pump shaft seal is worn or damaged. The oil box O-ring has deteriorated. There is an oil leak from gas-ballast control. There is an oil-leak from the drain-plug.

6 Storage and disposal

6.1 Storage

CAUTION

Observe the storage temperature limits stated in [Section 2](#). Storage below -30°C (-22°F) will permanently damage the pump seals.

Note: If storing a new pump in conditions of high humidity, remove the pump from its cardboard packaging box; dispose of the box (refer to [Section 6.2](#)).

Use the following procedure to store the pump:

1. Shut-down the pump as described in [Section 4.8](#).
2. Disconnect the pump from the electrical supply.
3. Purge the vacuum system and the pump with dry nitrogen and disconnect the pump from the vacuum system.
4. Replace the oil as described in [Section 5.4](#).
5. Place and secure protective covers over the inlet and outlet-ports.
6. Store the pump in cool, dry conditions until required for use. When required, prepare and install the pump as described in [Section 3](#). If the pump has been stored for more than a year, clean and overhaul the pump before installation. Follow the instructions supplied with the clean and overhaul kit.

6.2 Disposal

Dispose of the pump, the oil and any components removed from the pump safely in accordance with all local and national safety and environmental requirements.

Take particular care with the following:

- Components which have come into contact with the pump fluid.
- Components which have been contaminated with dangerous process substances.

Do not incinerate fluoroelastomer seals and O-rings.

This page has been intentionally left blank.

7 Service, spares and accessories

7.1 Introduction

Edwards products, spares and accessories are available from Edwards companies in Belgium, Brazil, China, France, Germany, Israel, Italy, Japan, Korea, Singapore, United Kingdom, U.S.A and a world-wide network of distributors. The majority of these centres employ Service Engineers who have undergone comprehensive Edwards training courses.

Order spare parts and accessories from your nearest Edwards company or distributor. When ordering, state for each part required:

- Model and Item Number of your equipment
- Serial number
- Item Number and description of part.

7.2 Service

Edwards products are supported by a world-wide network of Edwards Service Centres. Each Service Centre offers a wide range of options including: equipment decontamination; service exchange; repair; rebuild and testing to factory specifications. Equipment which has been serviced, repaired or rebuilt is returned with a full warranty.

Your local Service Centre can also provide Edwards engineers to support on-site maintenance, service or repair of your equipment.

For more information about service options, contact your nearest Service Centre or other Edwards company.

7.3 Spares

The following maintenance kits contain all of the parts needed to maintain your pump. The maintenance kits also include instructions for the use of the kits. Use the Clean and Overhaul Kit for routine maintenance operations. Use the Blade Kit together with the Clean and Overhaul Kit when renewing the blade assembly in the rotary pump.

Maintenance kit	Item Number
E2M0.7/E2M1/E2M1.5 Clean and Overhaul Kit	A371-01-131
E2M0.7/E2M1/E2MI.5 Blade Kit	A371-01-132
Ultragrade 15 oil, 1 litre	H110-26-015
Capacitor kit for part numbers A371-31-902 / A371-22-902 / A371-03-902 (110-120 V 30 µF)	A505-84-808
Capacitor kit for part numbers A371-31-919 / A371-22-919 / A371-03-919 (220-240 V 8 µF)	A505-84-809

7.4 Accessories

A comprehensive range of accessories is available for the pumps; refer to [Figure 5](#).

Items marked * require an NW25 adaptor, described in [Section 7.4.11](#).

7.4.1 Inlet catchpot *

The inlet catchpot traps any liquid droplets and prevents their entry into the pump.

Product	Item Number
IT020K Inlet catchpot	A441-10-000

7.4.2 Inlet dust filter *

The inlet dust filter protects the pump against abrasive dust.

Product	Item Number
ITF20K Inlet dust filter	A442-15-000

7.4.3 Inlet desiccant trap *

Use a desiccant trap when pumping limited quantities of water vapour at high pumping speeds to a low vapour pressure.

Product	Item Number
ITD20K Inlet desiccant trap	A445-10-000

7.4.4 Inlet chemical trap *

The inlet chemical trap protects the pump against chemically active gases.

Product	Item Number
ITC20K Inlet chemical trap	A444-10-000

7.4.5 Solenoid operated gas-ballast control valve

The valve provides remote or automatic on/off control of gas-ballast. The valve can be connected to shut-off ballast to prevent the return of air to the vacuum system when the pump is switched off.

Product	Electrical supply	Item Number
EBV20 gas-ballast control valve	220/240 V, single-phase, 50/60 Hz	A500-06-930
	100/120 V, single-phase, 50/60 Hz	A500-06-984

7.4.6 Foreline trap *

Use a Foreline trap on a clean pumping system to prevent back-migration of rotary pump oil vapour into your vacuum system.

Product	Item Number
FL20K Foreline trap	A133-05-000

7.4.7 Solenoid operated pipeline valve *

Fit the pipeline valve between the vacuum system and the pump inlet to provide additional system protection when the pump is switched off.

Product	Electrical supply	Item Number
PV10EK valve	200/240 V, single-phase, 50/60 Hz	C411-01-000
	110/127 V, single-phase, 50/60 Hz	C411-03-000

Figure 5 - Accessories

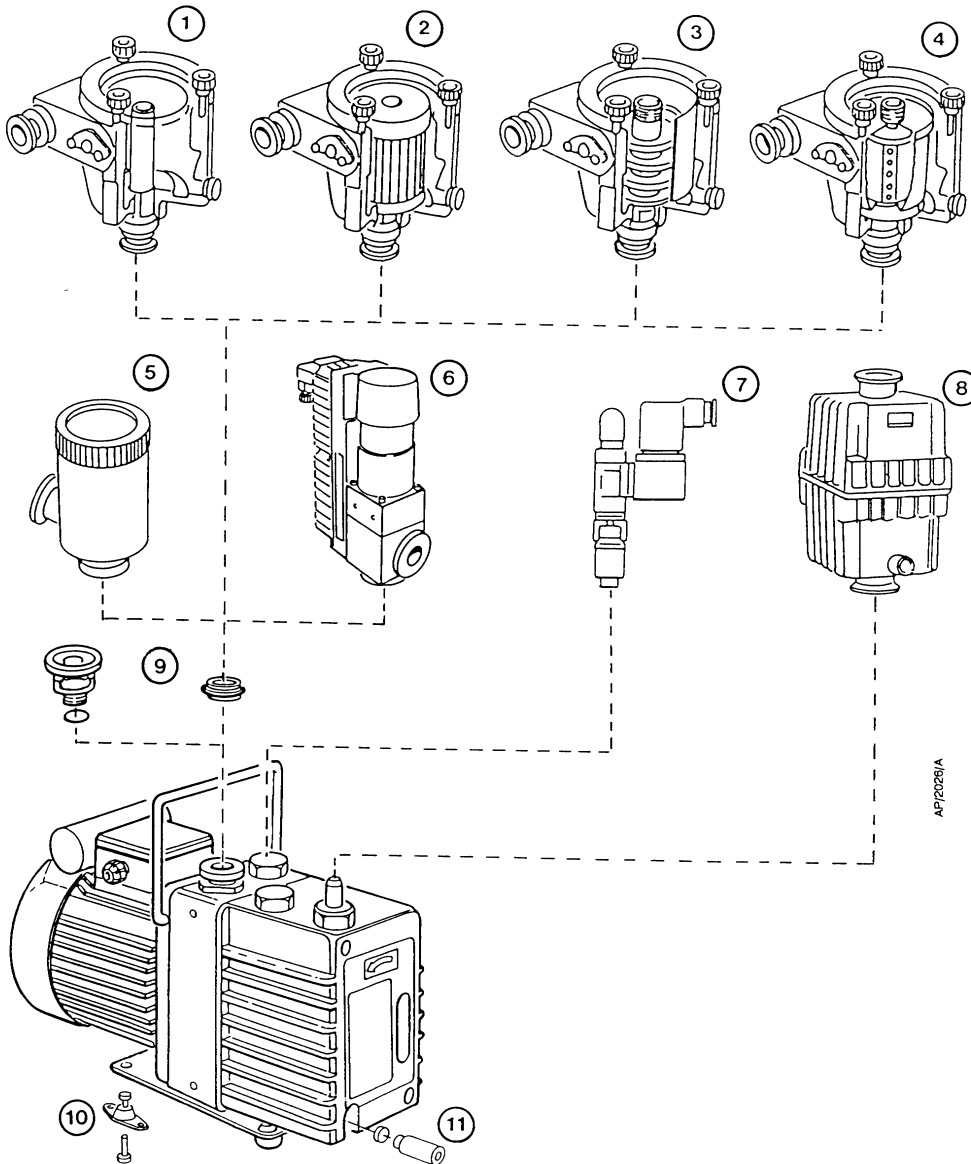

- | | |
|-------------------------------------|--|
| 1. Inlet catchpot | 7. Solenoid operated gas-ballast valve |
| 2. Inlet dust filter | 8. Outlet mist filter |
| 3. Inlet desiccant trap | 9. Flange adaptor kit |
| 4. Inlet chemical trap | 10. Vibration isolators |
| 5. Foreline trap | 11. Oil drain extension |
| 6. Solenoid operated pipeline valve | |

7.4.8 Outlet mist filter

The outlet mist filter separates and traps oil droplets in the pump outlet to prevent oil mist discharge.

Product	Item Number
EMF3 Outlet mist filter	A462-20-000

7.4.9 Oil drain extension

Fit the oil drain extension between the oil drain port on the pump and the oil drain-plug to make the drainage of oil from the pump easier. The pack includes an oil drain extension tube for use when oil is gravity drained.

Product	Item Number
Oil drain extension	A505-03-000

7.4.10 Vibration isolators

The vibration isolators reduce transmission vibration and noise when the pump is floor or frame mounted and to help to reduce strain when the mounting area is uneven.

Product	Item Number
Vibration isolators (pack of four)	A248-01-407

7.4.11 Pump inlet or outlet NW25 adaptor

This is a 3/8 inch BSP to NW25 adaptor, supplied with connection hardware. Use this adaptor when removing the NW10 adaptor fitted to the pump-inlet or the outlet-nozzle fitted to the pump outlet, to adapt the 3/8 inch BSP thread to NW25.

Product	Item Number
Pump inlet adaptor	A371-01-028

Index

A

Accessories 27
ATEX directive implications..... 2, 15

C

Check the direction of rotation 11
Check the oil-level 20
Clean and overhaul the pump 22
Clean or replace the gas-ballast O-ring..... 21
Clean the motor fan-cover and enclosure 22
Connect the pump to the electrical supply 11

D

Description 4
Disposal 25

E

Electrical data 6
Electrical installation 10

F

Fault finding..... 23
Fill the pump with oil..... 10
Fit new blades 22
Flammable/pyrophoric materials 15
Foreline trap 28

G

Gas purges 15
Gas-ballast..... 4
Gas-ballast control 16
General requirements 11

I

Inlet catchpot 27
Inlet chemical trap 28
Inlet desiccant trap 28
Inlet dust filter..... 28
Inlet-port connection 11
Inspect and clean the inlet-filter 21

L

Leak-test the system..... 13
Locate the pump..... 10
Lubrication data 7

M

Maintenance..... 19
Maintenance plan..... 19
Mechanical data 6

O

Oil drain extension 30
Operating and storage conditions..... 5
Outlet mist filter 30

P

Performance 5
Pump inlet or outlet NW25 adaptor 30

R

Replace the oil..... 20

S

Safety 9
Safety information 19
Scope and definitions..... 1
Service 27
Service, spares and accessories 27
Shut-down 18
Side inlet-port connection 12
Solenoid operated gas-ballast control valve 28
Solenoid operated pipeline valve 28
Start-up procedure..... 16
System design 9

T

Test the motor condition 22
To achieve ultimate vacuum 17
To decontaminate the oil 17
To pump condensable vapours 17

U

Unattended operation 18
Unpack and inspect 10

V

Vibration isolators 30

This page has been intentionally left blank.