



JC7218 series is a high voltage (up to 15V) ultra-low quiescent current low dropout voltage regulator (LDO) manufactured in CMOS processes. It can deliver up to 1A of current while consuming only 1.6uA of quiescent current. It consists of a reference voltage generator, an error amplifier, a current foldback circuit, and a phase compensation circuit plus a driver transistor. The JC7218 series is designed specifically for applications where very-low  $I_q$  is a critical parameter. This

device maintains low quiescent current consumption even in dropout mode to further increase the battery life.

**■ Features:**

- Ultra-low Quiescent Current: 1.6uA
- Maximum Input Voltage: 15V
- Output Voltage Highly Accurate:  $\pm 2\%$
- Maximum Output Current: 1A
- Dropout Voltage: 650mV@ $I_{OUT}=1A$
- Temperature Stability:  $\pm 50\text{ppm}/^\circ\text{C}$
- Protections Circuits: Current Limiter, Short Circuit, Foldback, Thermal shutdown
- Output Capacitor: Low ESR Ceramic Capacitor Compatible

**■ Applications:**

- Smart wearer
- Long-life battery-powered devices
- Portable mobile devices, such as mobile phones, cameras, and so on
- Wireless communication equipment

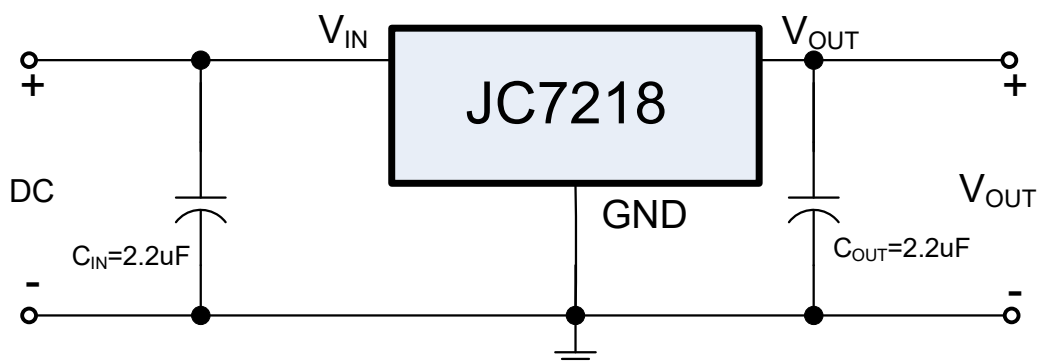
**■ Typical Application:**

■ Pin Configuration (Top View):

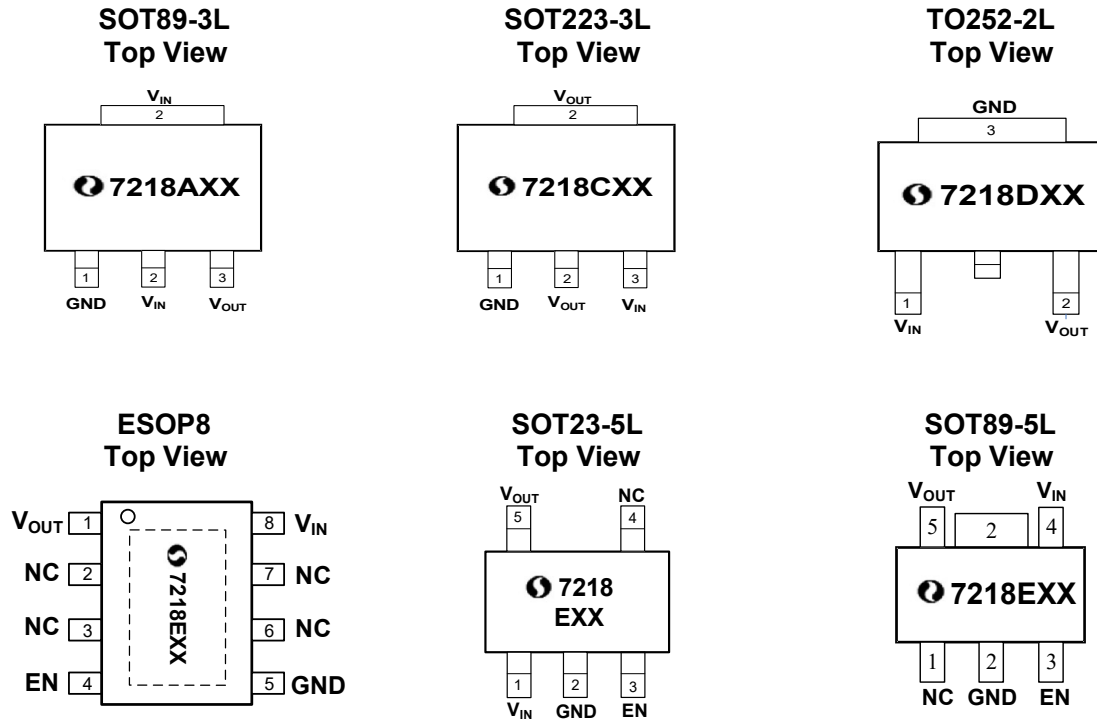

■ Product Selections

Product Name	$V_{OUT}$ (V)	Package	Ordering Name	Marking	Package Information
JC7218A30	3.0	SOT89-3L	JC7218A30PA1	7218A30	Tape and Reel, 1000pcs
JC7218A33	3.3	SOT89-3L	JC7218A33PA1	7218A33	
JC7218A36	3.6	SOT89-3L	JC7218A36PA1	7218A36	
JC7218A38	3.8	SOT89-3L	JC7218A38PA1	7218A38	
JC7218A40	4.0	SOT89-3L	JC7218A40PA1	7218A40	
JC7218A50	5.0	SOT89-3L	JC7218A50PA1	7218A50	
JC7218AC0	12.0	SOT89-3L	JC7218AC0PA1	7218AC0	
JC7218E33	3.3	SOT89-5L	JC7218E33PC1	7218E33	Tape and Reel, 2500pcs
JC7218E36	3.6	SOT89-5L	JC7218E36PC1	7218E36	
JC7218E50	5.0	SOT89-5L	JC7218E50PC1	7218E50	
JC7218C30	3.0	SOT223-3L	JC7218C30YA2	7218C30	
JC7218C33	3.3	SOT223-3L	JC7218C33YA2	7218C33	
JC7218C36	3.6	SOT223-3L	JC7218C36YA2	7218C36	
JC7218C40	4.0	SOT223-3L	JC7218C40YA2	7218C40	
JC7218C50	5.0	SOT223-3L	JC7218C50YA2	7218C50	Tape and Reel, 2500pcs
JC7218CC0	12.0	SOT223-3L	JC7218CC0YA2	7218CC0	
JC7218D30	3.0	TO252-2L	JC7218D30UA2	7218D30	
JC7218D33	3.3	TO252-2L	JC7218D33UA2	7218D33	
JC7218D36	3.6	TO252-2L	JC7218D36UA2	7218D36	
JC7218D40	4.0	TO252-2L	JC7218D40UA2	7218D40	
JC7218D50	5.0	TO252-2L	JC7218D50UA2	7218D50	
JC7218D80	8.0	TO252-2L	JC7218D80UA2	7218D80	Tape and Reel, 2500pcs
JC7218DC0	12.0	TO252-2L	JC7218DC0UA2	7218DC0	

JC7218E30	3.0	ESOP8	JC7218E30SF4	7218E30	Tape and Reel, 4000pcs
JC7218E33	3.3	ESOP8	JC7218E33SF4	7218E33	
JC7218E36	3.6	ESOP8	JC7218E36SF4	7218E36	
JC7218E40	4.0	ESOP8	JC7218E40SF4	7218E40	
JC7218E50	5.0	ESOP8	JC7218E50SF4	7218E50	
JC7218EC0	12.0	ESOP8	JC7218EC0SF4	7218EC0	
JC7218E30	3.0	SOT23-5L	JC7218E30QC3	7218E30	Tape and Reel, 3000pcs
JC7218E33	3.3	SOT23-5L	JC7218E33QC3	7218E33	
JC7218E36	3.6	SOT23-5L	JC7218E36QC3	7218E36	
JC7218E40	4.0	SOT23-5L	JC7218E40QC3	7218E40	
JC7218E50	5.0	SOT23-5L	JC7218E50QC3	7218E50	

**Notes:**

1\* Customer can request to customize the output voltage ranged from 1.8V to 12V, if desired voltage is not found in the selections

2\* Customer can request customization of package choice

3\* Please pay attention to the MARKING of the product package type

**■ Absolute Maximum Ratings (Unless otherwise indicated:  $T_a=25^{\circ}\text{C}$ )**

PARAMETER	SYMBOL	RATINGS		UNITS
Input Voltage	$V_{IN}$	-0.3 ~ 15		V
Output Voltage	$V_{OUT}$	$V_{SS}-0.3 \sim V_{IN}+0.3V$		
Power Dissipation	$P_D$	SOT89-3L	1000	mW
		SOT89-5L	1000	
		SOT223-3L	1500	
		TO252-2L	1800	
		ESOP8	800	
		SOT23-5L	250	
Thermal Resistance	$R_{\theta JB}^{(1)}$	SOT89-3L	100	$^{\circ}\text{C/W}$
		SOT89-5L	100	
		SOT223-3L	66	
		TO252-2L	55	
		ESOP8	80	
		SOT23-5L	180	
Operating Ambient Temperature	$T_{opr}$	-40 ~ +85		$^{\circ}\text{C}$
Storage Temperature	$T_{stg}$	-40 ~ +125		
ESD Protection	ESD HBM	4000		V

**Note:** Stresses above those listed under "Absolute Maximum Ratings" may cause permanent damage to the device.

<sup>(1)</sup> Mounted on JEDEC standard 4layer (2s2p) PCB test board

**■ Electrical Characteristics:**

JC7218 Series (Unless otherwise indicated :  $T_a=25^\circ\text{C}$ )

PARAMETER	SYMBOL	CONDITIONS		MIN.	TYP.	MAX.	UNIT
Output Voltage*1	$V_{OUT(S)}$	$V_{IN}=V_{OUT(S)}+2V, I_{OUT}=1mA$		$V_{OUT(S)} \diamond$ 0.98	$V_{OUT(S)}$	$V_{OUT(S)} \diamond$ 1.02	V
Dropout Voltage*2	$V_{DROP}$	$I_{OUT}=1mA$			4	8	mV
		$I_{OUT}=1A$			650	900	
Line Regulation	$\frac{\Delta V_{OUT}}{\Delta V_{IN} \cdot V_{OUT(S)}}$	$V_{OUT(S)}+2V \leq V_{IN} \leq 15V$ $I_{OUT}=1mA$			0.01	0.02	%/V
Load Regulation	$\frac{\Delta V_{OUT}}{I_{OUT2}}$	$V_{IN}=V_{OUT(S)}+2V$ $1mA \leq I_{OUT} \leq 1A$	$V_{OUT(S)} \leq 5.0V$		80		mV
			$V_{OUT(S)} > 5.0V$		90		
Temperature Stability	$\frac{\Delta V_{OUT}}{T_a \cdot V_{OUT(S)}}$	$V_{IN}=V_{OUT(S)}+2V, I_{OUT}=1mA$ $-40^\circ\text{C} \leq T_a \leq 125^\circ\text{C}$			$\pm 50$		ppm/ °C
GND Current	$I_{GND}$	no load	$V_{OUT(S)} \leq 5.0V$	1	1.6	2	$\mu\text{A}$
			$V_{OUT(S)} > 5.0V$	1.5	2.3	3	
		$I_{OUT}=100mA$				420	
Input Voltage	$V_{IN}$	---		2.2		18	V
Maximum Output Current	$I_{OUTMAX}$			1			A
Current Limit*3	$I_{LIM}$	$V_{IN}=V_{OUT(S)}+2V,$ $V_{OUT}=0.95 \times V_{OUT(S)}$			1.5		
Power Supply Rejection Ratio*4	PSRR	$f=10\text{Hz}, I_{OUT}=10\text{mA}$			71		dB
		$f=100\text{Hz}, I_{OUT}=10\text{mA}$			70		
		$f=1\text{kHz}, I_{OUT}=10\text{mA}$			51		
Short Circuit Current	$I_{SHORT}$	$V_{IN}=V_{OUT(S)}+2.0V$ $V_{OUT}=0V$			30		mA
Over Temperature Protection	OTP	$I_{OUT}=1mA$			150		°C

Notes:

1.  $V_{OUT(S)}$ : Output voltage when  $V_{IN}=V_{OUT}+2V, I_{OUT}=1\text{ mA}$ .
2.  $V_{DROP}=V_{IN1} - (V_{OUT(S)} \times 0.98)$  where  $V_{IN1}$  is the input voltage when  $V_{OUT} = V_{OUT(S)} \times 0.98$ .
3.  $I_{LIM}$ : Output current when  $V_{IN}=V_{OUT(S)}+2V$  and  $V_{OUT} = 0.95 \times V_{OUT(S)}$ .
4. PSRR was measured for  $V_{OUT(S)} = 5V$  and  $V_{IN} = 7V$ .

■ Typical Performance Characteristics:

Test Conditions:  $V_{IN}=V_{OUT}+2.0V$ ,  $C_{IN}=2.2\mu F$ ,  $C_{OUT}=2.2\mu F$ , unless otherwise indicated.

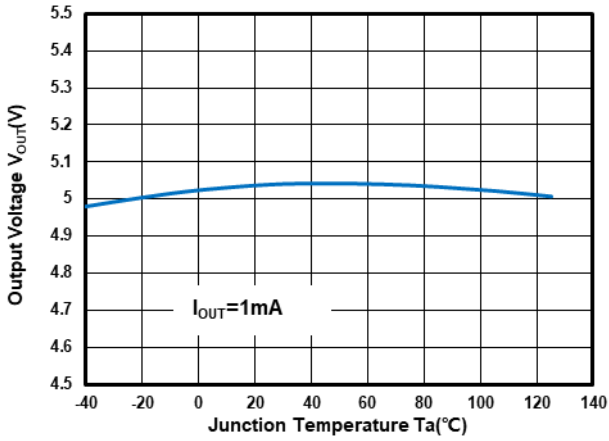

Output Voltage vs Temperature at  $V_{OUT}=5.0V$

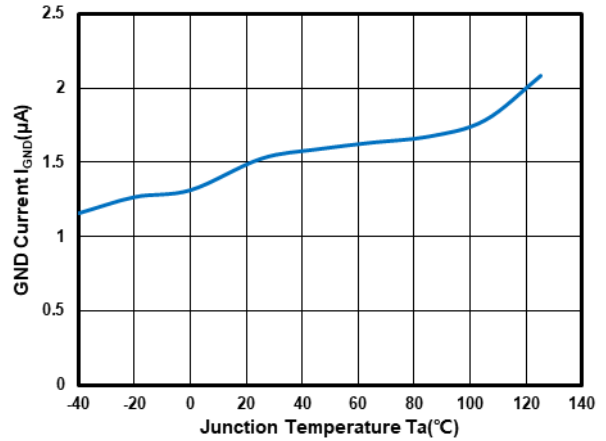

GND Current vs Temperature at  $V_{OUT}=5.0V$

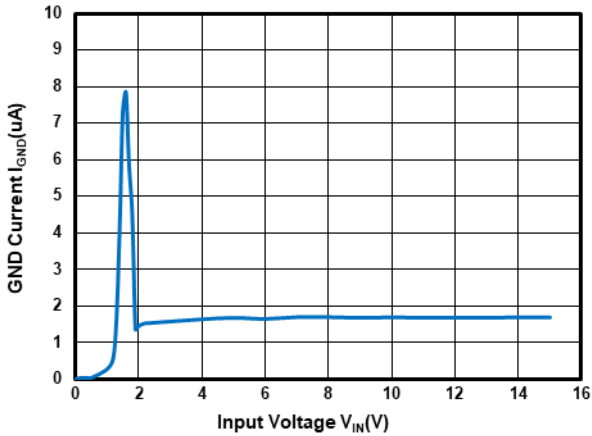

GND Current vs Input Voltage at  $V_{OUT}=5.0V$

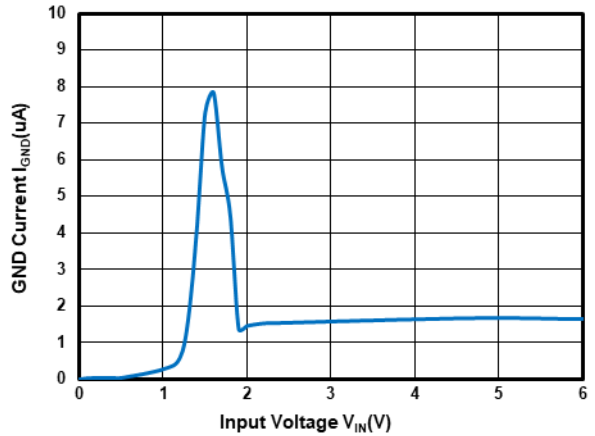

GND Current vs Input Voltage at  $V_{OUT}=5.0V$

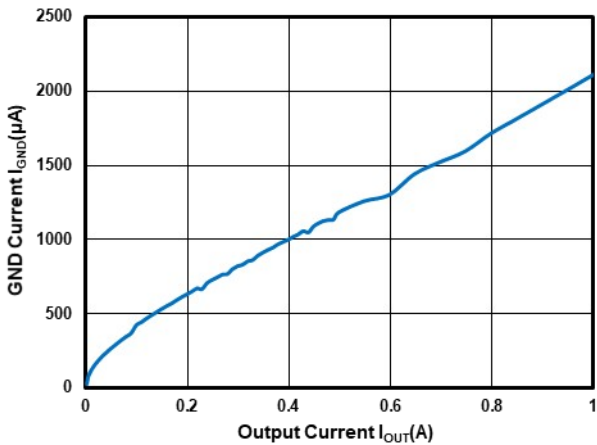

GND Current vs Output Current at  $V_{OUT}=5.0V$

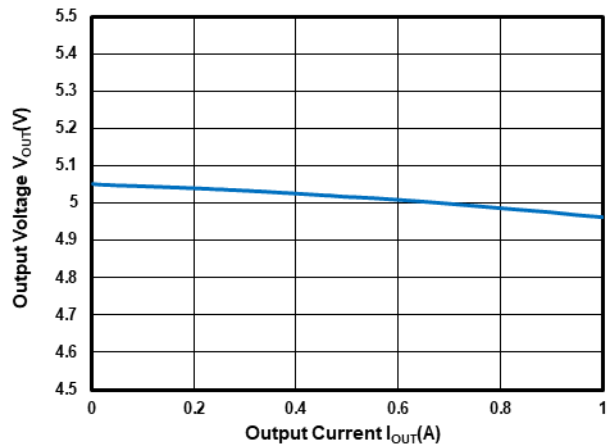

Output Voltage vs Output Current at  $V_{OUT}=5.0V$

■ Typical Performance Characteristics (Continued):

Test Conditions:  $V_{IN}=V_{OUT}+2.0V$ ,  $C_{IN}=2.2\mu F$ ,  $C_{OUT}=2.2\mu F$ , unless otherwise indicated.

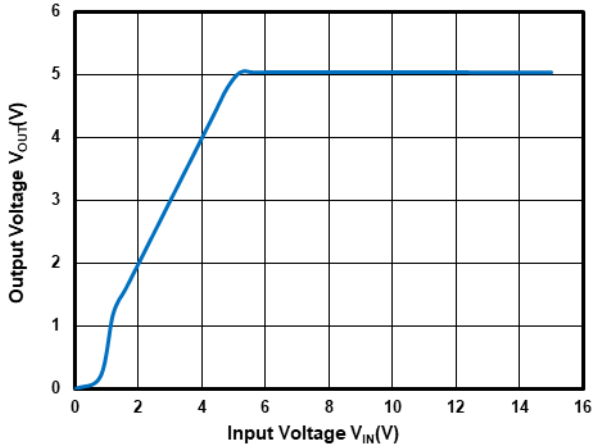

Output Voltage vs Input Voltage at  $V_{OUT}=5.0V$

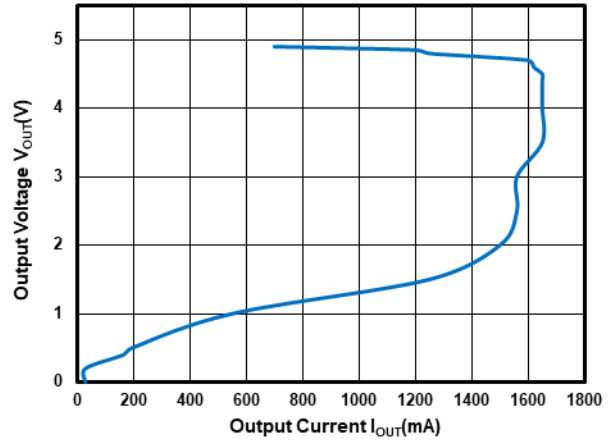

Output Current Fold-back at  $V_{OUT}=5.0V$

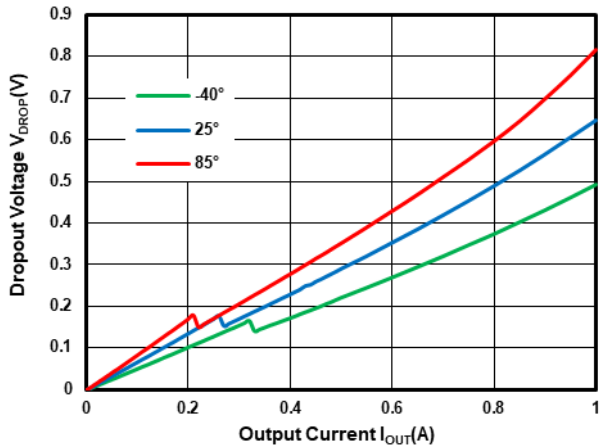

Dropout Voltage vs Temperature at  $V_{OUT}=5.0V$

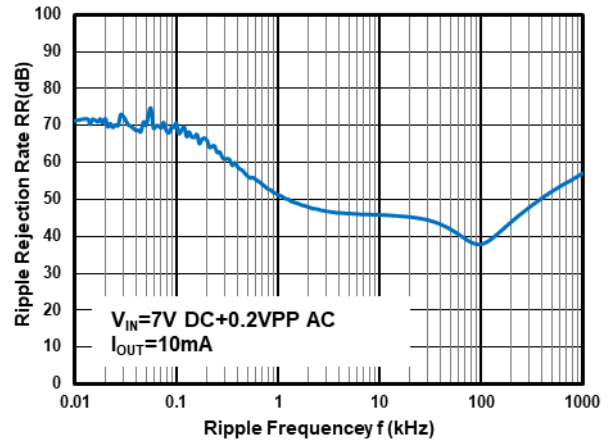

Power Supply Rejection Ratio at  $V_{OUT}=5.0V$

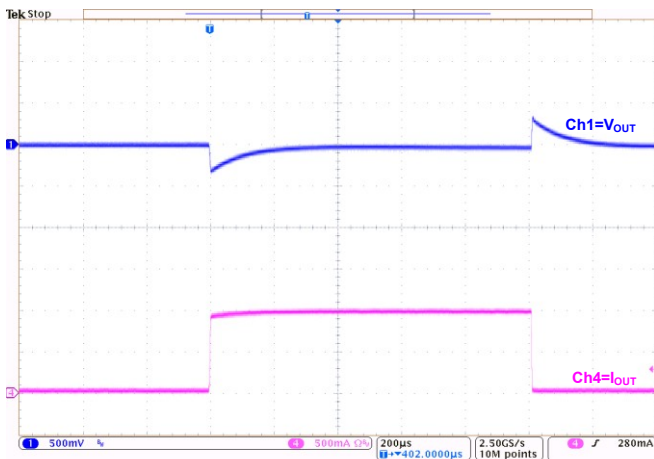

Load Transient at  $V_{OUT}=5.0V$   
( $I_{OUT}=1mA\sim 1A\sim 1mA$ )

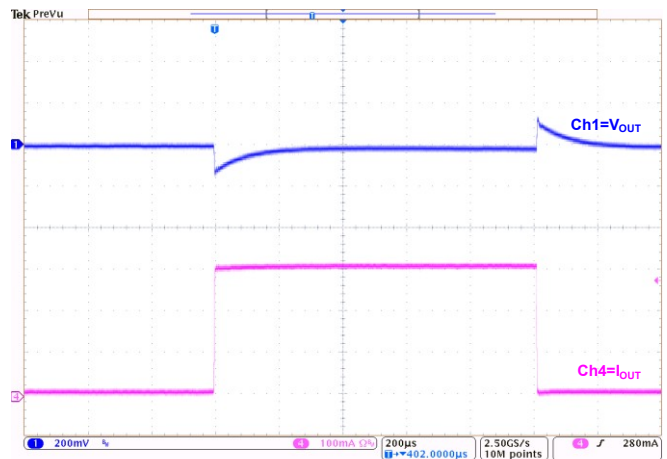

Load Transient at  $V_{OUT}=5.0V$   
( $I_{OUT}=1mA\sim 300mA\sim 1mA$ )

■ Typical Performance Characteristics (Continued):

Test Conditions:  $V_{IN}=V_{OUT}+2.0V$ ,  $C_{IN}=2.2\mu F$ ,  $C_{OUT}=2.2\mu F$ , unless otherwise indicated.

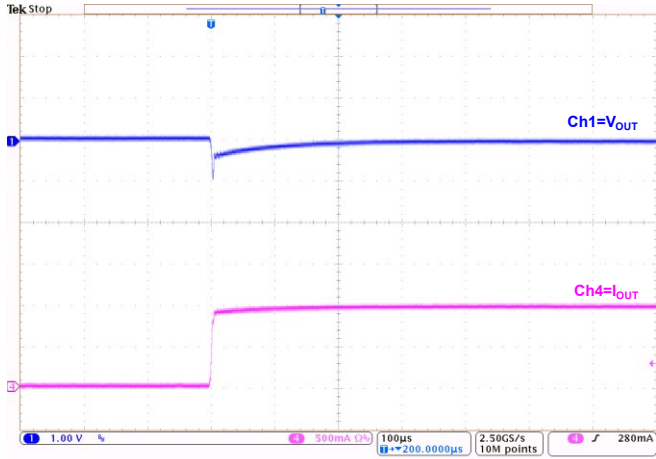

Load Transient at  $V_{OUT}=5.0V$   
( $I_{OUT}=0mA\sim 1A$ )

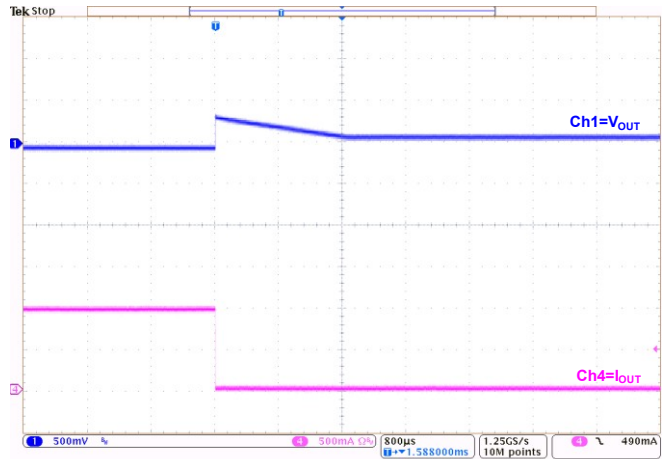

Load Transient at  $V_{OUT}=5.0V$   
( $I_{OUT}=1A\sim 0mA$ )

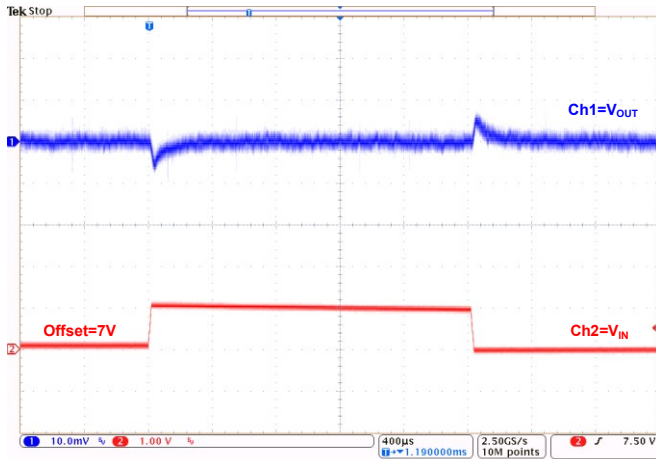

Line Transient at  $V_{OUT}=5.0V$   
( $I_{OUT}=1mA$ )

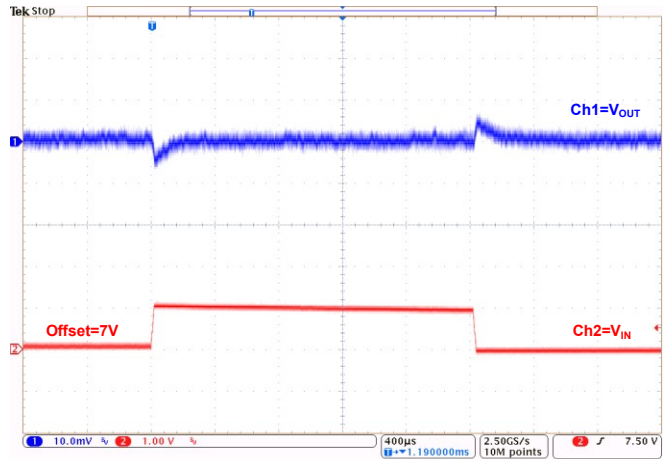

Line Transient at  $V_{OUT}=5.0V$   
( $I_{OUT}=10mA$ )

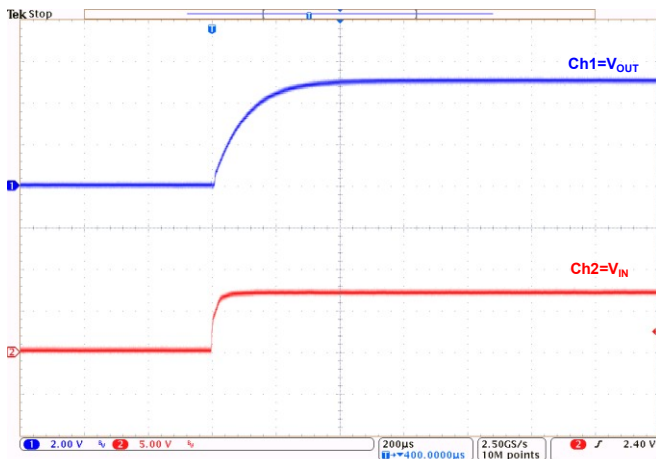

Power-Up at  $V_{OUT}=5.0V$ :  
( $I_{OUT}=1mA$ )

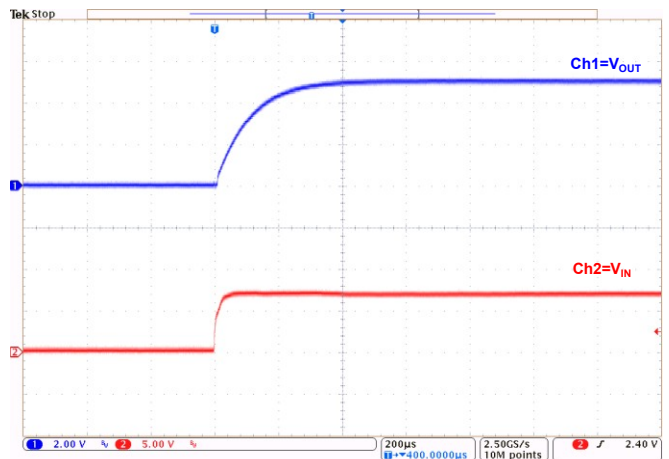

Power-Up at  $V_{OUT}=5.0V$ :  
( $I_{OUT}=1A$ )

■ Typical Performance Characteristics (Continued):

Test Conditions:  $V_{IN}=V_{OUT}+2.0V$ ,  $C_{IN}=2.2\mu F$ ,  $C_{OUT}=2.2\mu F$ , unless otherwise indicated.

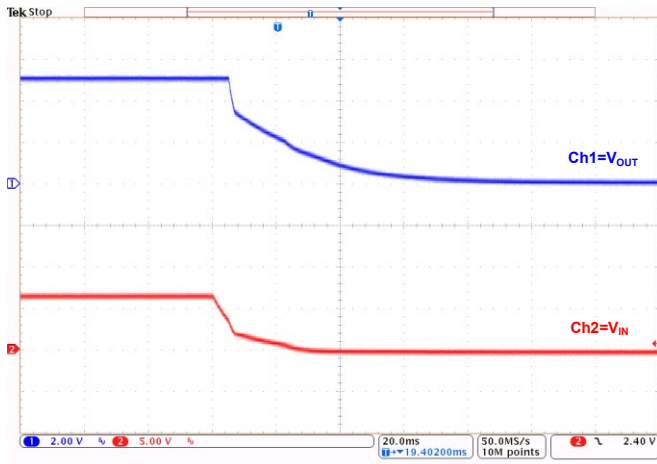

Power-Down at  $V_{OUT}=5.0V$ :  
( $I_{OUT}=1mA$ )

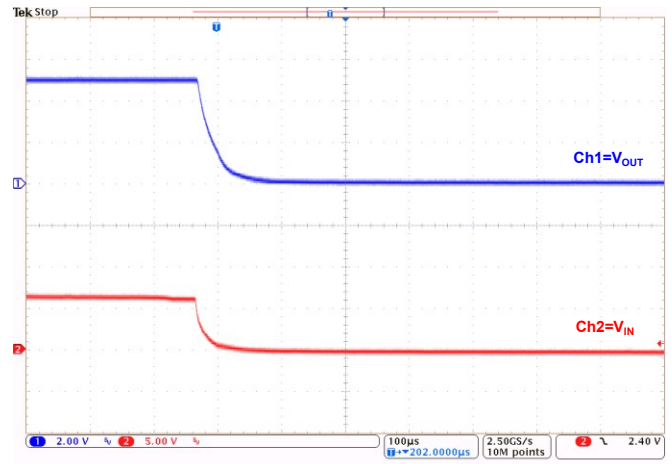

Power-Down at  $V_{OUT}=5.0V$ :  
( $I_{OUT}=1A$ )



## ■ Operational Explanation

### Output voltage control

The voltage divided by resistors R1 and R2 is compared with the internal reference voltage by the error amplifier. The amplifier output then drives the P-channel MOSFET connected to the  $V_{OUT}$  pin. The output voltage at the  $V_{OUT}$  pin is regulated by this negative feedback system. The current limit circuit and short protect circuit operate in relation to output current level.

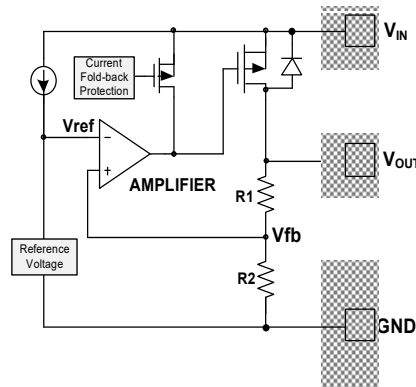

### ■ Pass transistor

The pass transistor with low turn-on resistance used in JC7218 is a P-channel MOSFET. If the potential on  $V_{OUT}$  pin is higher than  $V_{IN}$ , it is possible that IC will be destroyed due to reverse current which is caused by parasitic diodes between  $V_{IN}$  and  $V_{OUT}$ . Therefore, the  $V_{OUT}$  pin potential exceeds  $V_{IN}+0.3V$  is not allowed.

### ■ Current limit, over temperature protection

The JC7218 series includes a combination of a fixed current limiter circuit which aid the operations of the current limiter and circuit protection. When the load current reaches the current limit level, the fixed current limiter circuit operates and output voltage drops. As a result of this drop in output voltage, the foldback circuit operates, output voltage drops further and output current decreases.

Special attention should be paid to that the product of the dropout voltage on the chip and the output current must be smaller than the heat dissipation. If power consumption on the chip is more than the heat dissipation, OTP will protect the chip from damaging due to over temperature.

### ■ Notes:

1. The input and output capacitors should be placed as close as possible to the IC.
2. If the impedance of the power supply is high, which is caused by forgetting installing input capacitor or installing too small value capacitor, the oscillation may occur.
3. Pay attention to the operation conditions of input and output voltage and load current, such that the power consumption in the IC should not exceed the allowable power consumption of the package even though the chip has short circuit protection.
4. IC has a built-in anti-static protection (ESD) circuit, but please do not add excessive stress to the IC.

■ Packaging Information

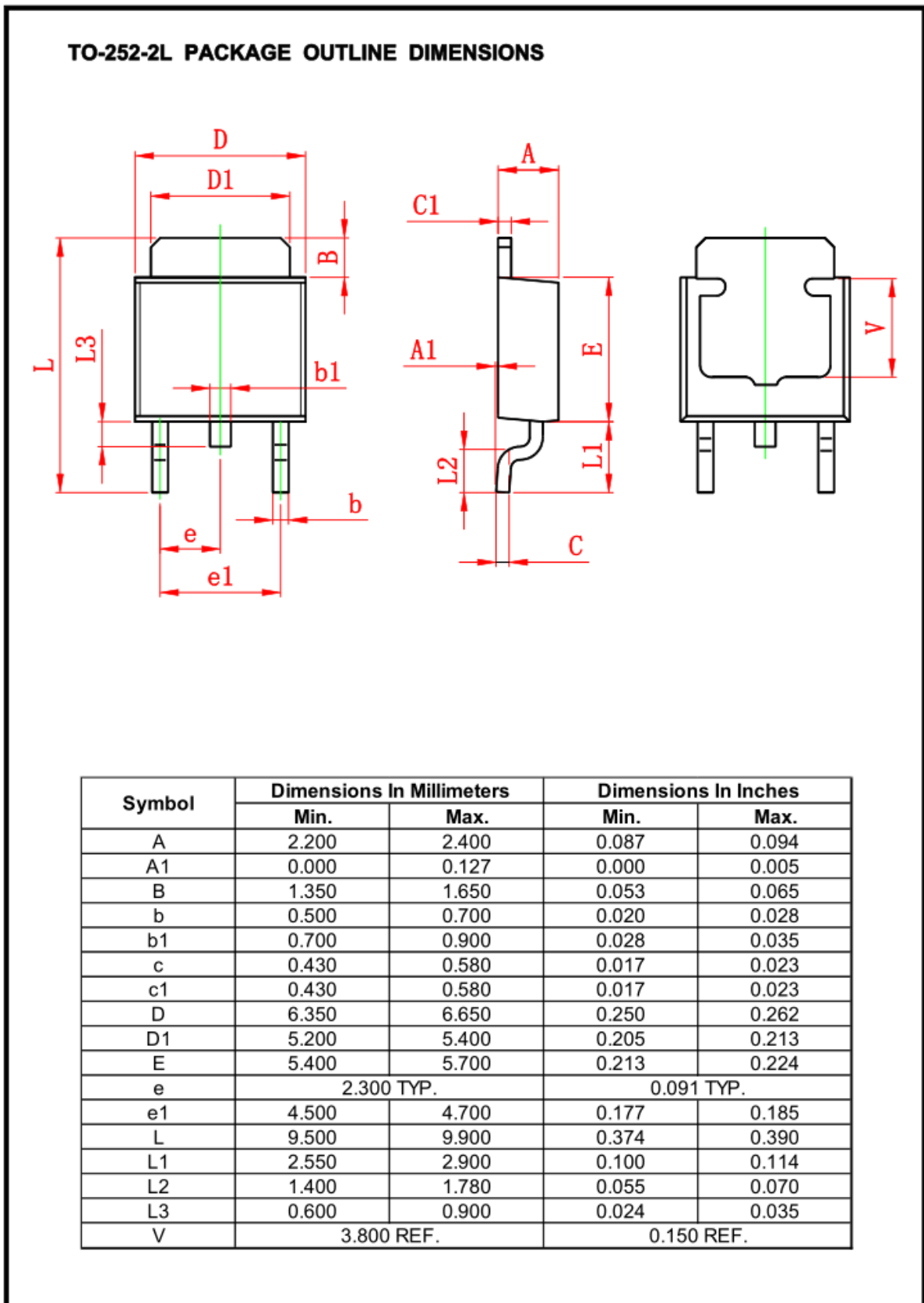

■ Packaging Information (Continued)

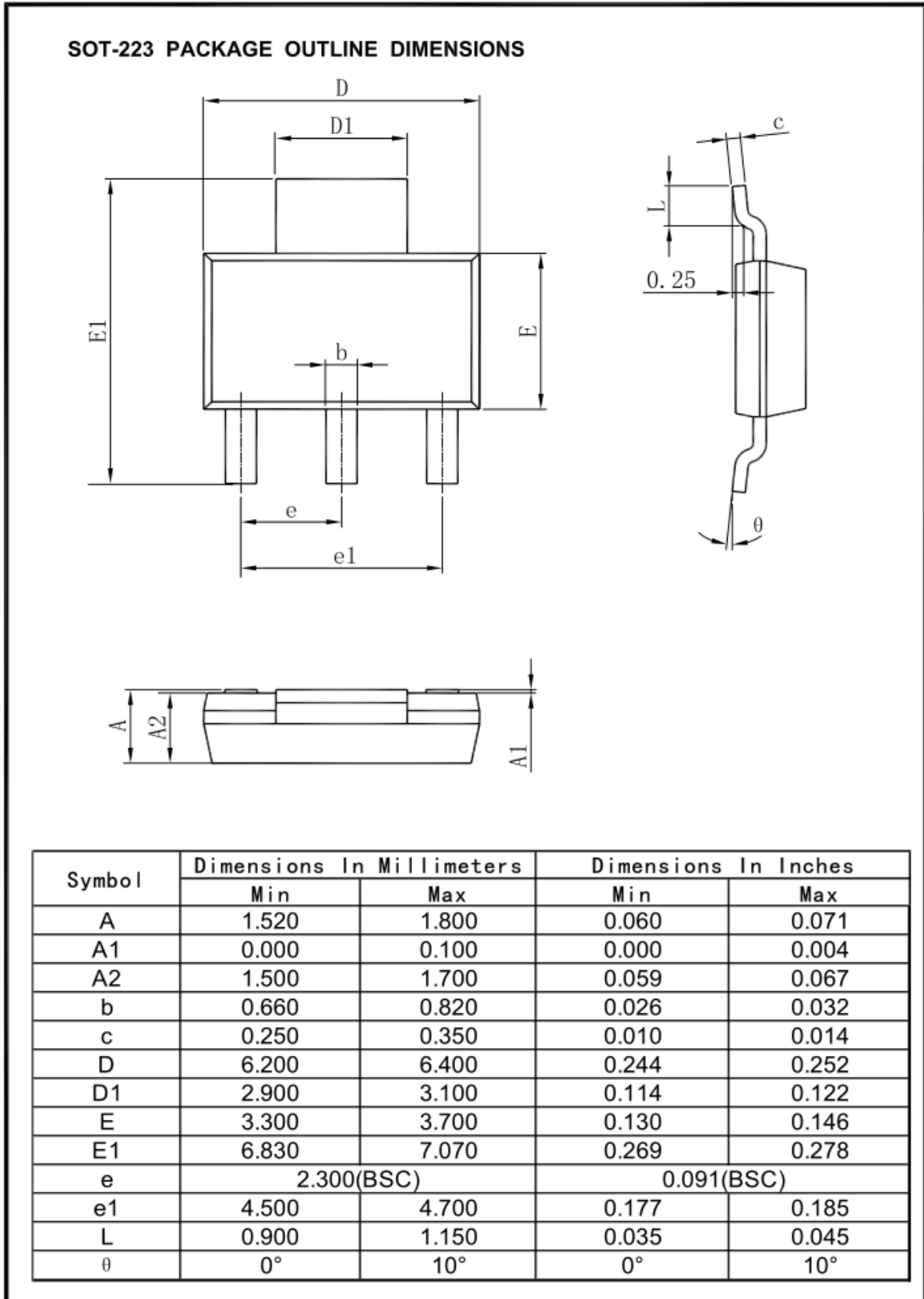

■ Packaging Information (Continued)

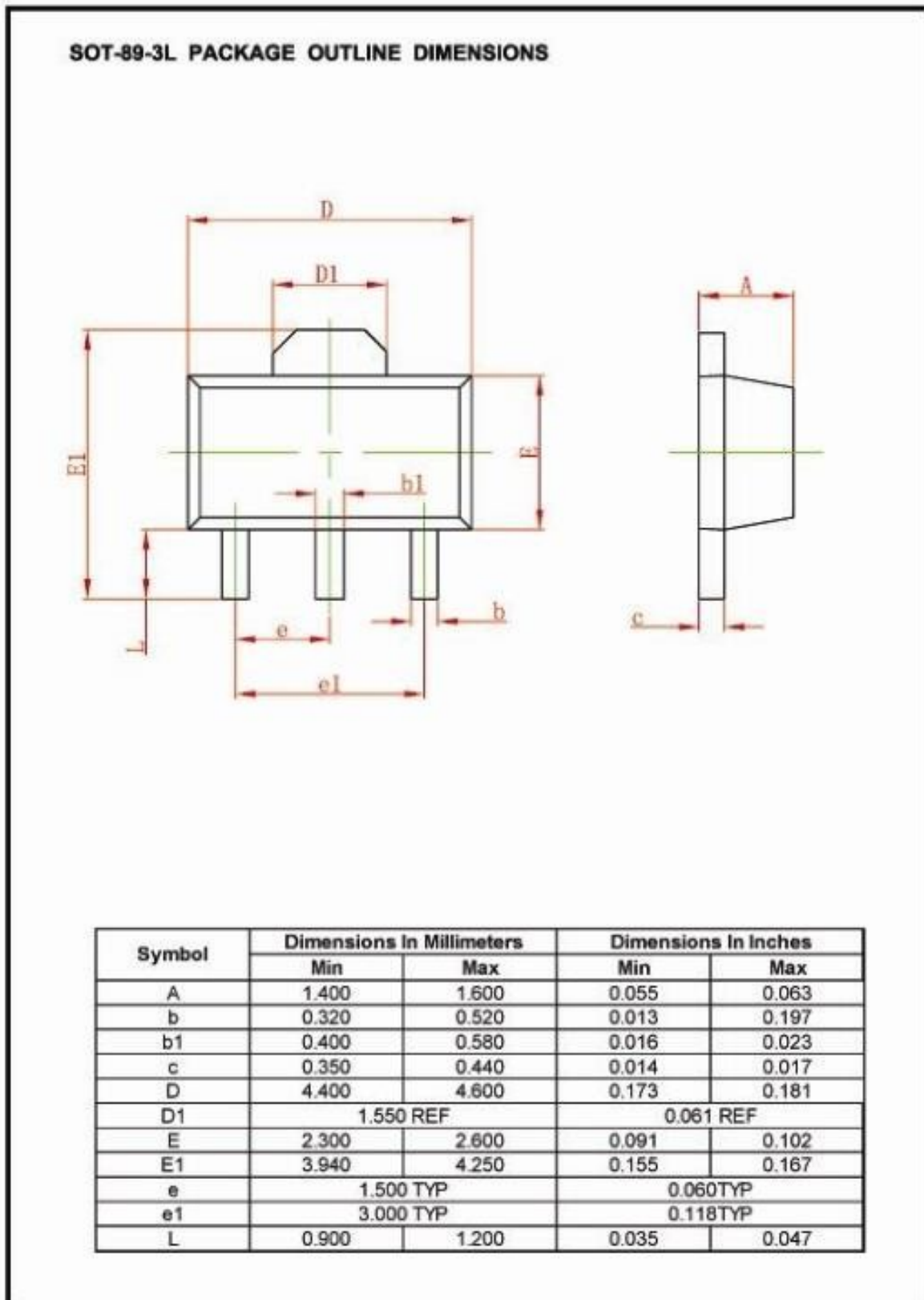

■ Packaging Information (Continued)

ESOP8 PACKAGE OUTLINE DIMENSIONS

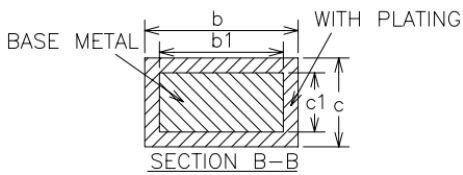
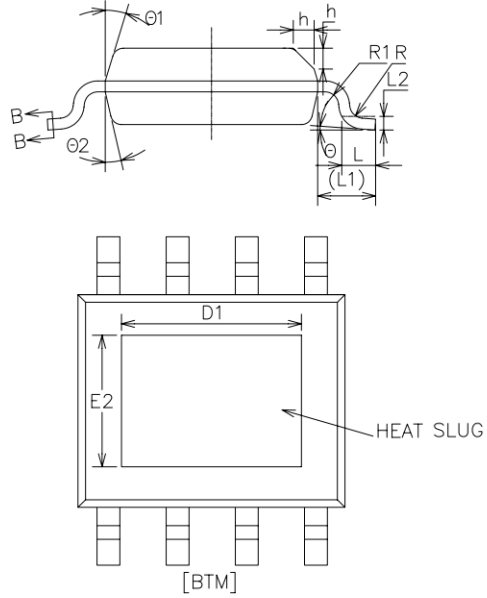
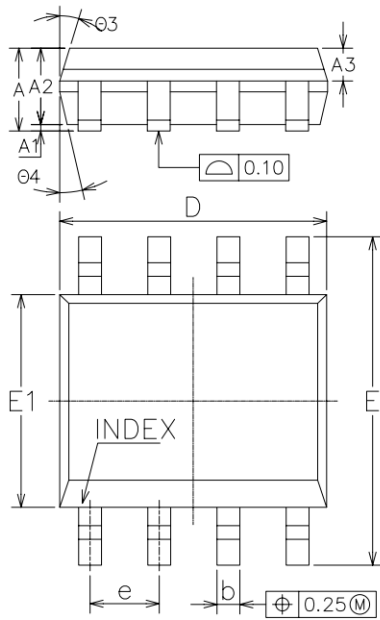

COMMON DIMENSIONS  
(UNITS OF MEASURE=MILLIMETER)

SYMBOL	MIN	NOM	MAX	
A	1.35	1.55	1.70	
A1	0	0.10	0.15	
A2	1.25	1.40	1.65	
A3	0.50	0.60	0.70	
b	0.38	-	0.51	
b1	0.37	0.42	0.47	
c	0.17	-	0.25	
c1	0.17	0.20	0.23	
D	4.80	4.90	5.00	
D1	Option 1	3.10	3.30	3.50
	Option 2	2.09	2.29	2.49
E	5.80	6.00	6.20	
E1	3.80	3.90	4.00	
E2	Option 1	2.20	2.40	2.60
	Option 2	2.09	2.29	2.49
e	1.17	1.27	1.37	
L	0.45	0.60	0.80	
L1	1.04REF			
L2	0.25BSC			
R	0.07	-	-	
R1	0.07	-	-	
h	0.30	0.40	0.50	
$\theta$	0°	-	8°	
$\theta 1$	15°	17°	19°	
$\theta 2$	11°	13°	15°	
$\theta 3$	15°	17°	19°	
$\theta 4$	11°	13°	15°	

■ Packaging Information (Continued)

封装尺寸

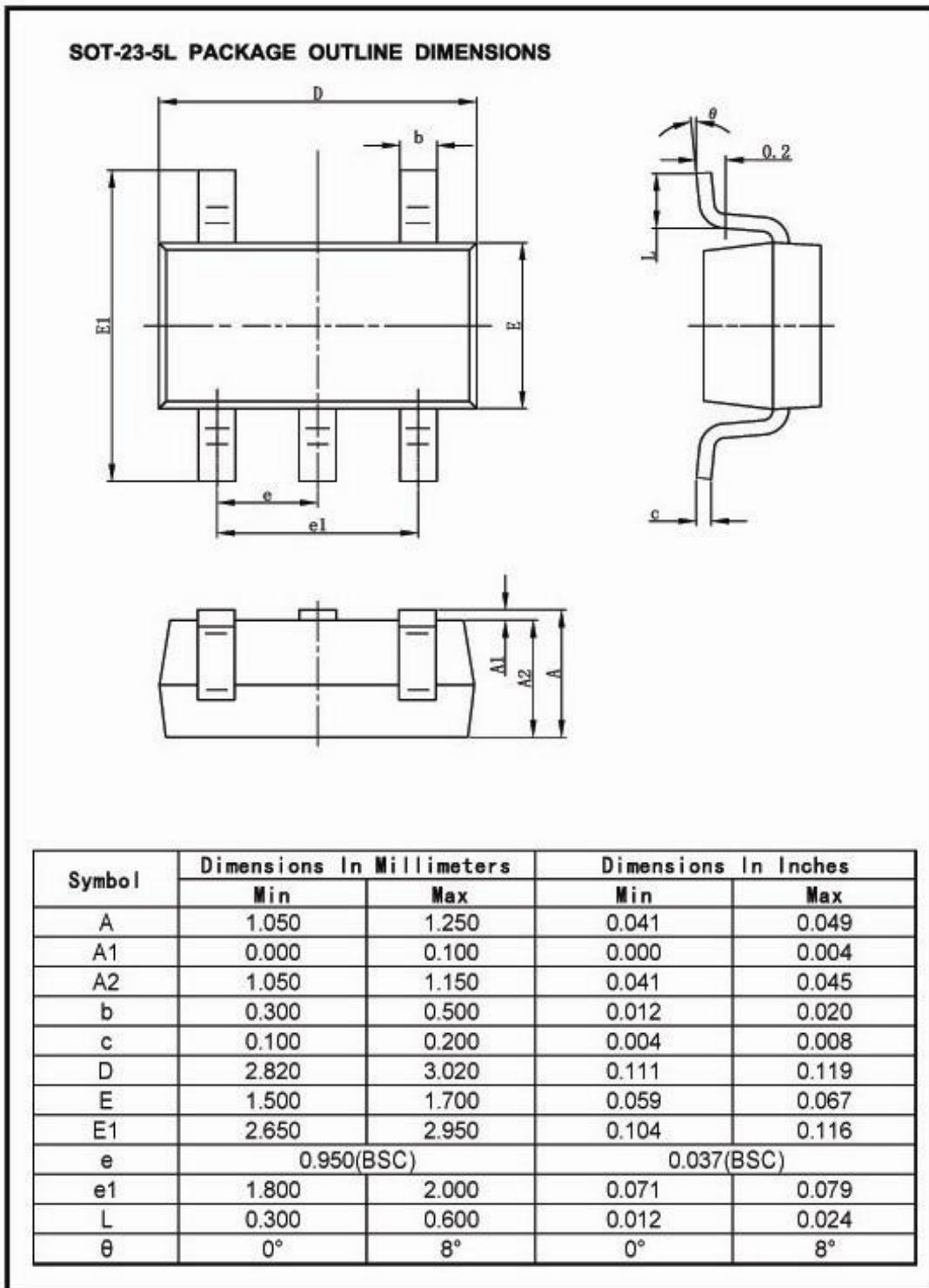

封装尺寸

SOT-89-5L PACKAGE OUTLINE DIMENSIONS

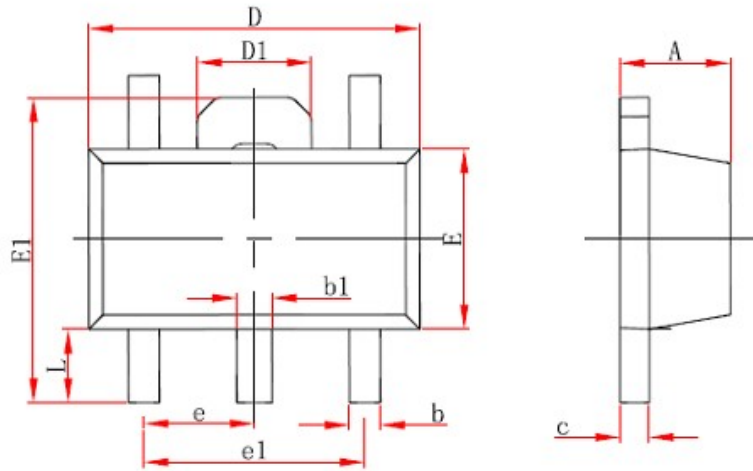

Symbol	Dimensions In Millimeters		Dimensions In Inches	
	Min.	Max.	Min.	Max.
A	1.400	1.600	0.055	0.063
b	0.320	0.520	0.013	0.020
b1	0.380	0.580	0.015	0.023
c	0.350	0.440	0.014	0.017
D	4.400	4.600	0.173	0.181
D1	1.550 REF.		0.061 REF.	
E	2.300	2.600	0.091	0.102
E1	3.940	4.250	0.155	0.167
e	1.500 TYP.		0.060 TYP.	
e1	3.000 TYP.		0.118 TYP.	
L	0.900	1.200	0.035	0.047