



# Standard Test Method for Breaking Strength and Elongation of Textile Webbing, Tape and Braided Material<sup>1</sup>

This standard is issued under the fixed designation D 6775; the number immediately following the designation indicates the year of original adoption or, in the case of revision, the year of last revision. A number in parentheses indicates the year of last reapproval. A superscript epsilon ( $\epsilon$ ) indicates an editorial change since the last revision or reapproval.

<sup>ε1</sup> NOTE—Figures were added editorially in September 2002.

## 1. Scope

1.1 This test method covers the determination of the breaking strength and elongation of textile webbing, tape and braided materials using a split-drum type specimen clamp.

1.2 This test method is limited to materials with a maximum width of 90 mm (3.5 in.) and a maximum breaking strength of no more than 89000N (20000 lb).

1.3 The values stated in either SI units or U.S. Customary units are to be regarded separately as standard. Within the text, the U.S. Customary units are given in parentheses. The values stated in each system are not exact equivalents; therefore, each system shall be used independently of the other.

1.4 *This standard does not purport to address all of the safety concerns, if any, associated with its use. It is the responsibility of the user of this standard to establish appropriate safety and health practices and determine the applicability of regulatory limitations prior to use.*

## 2. Referenced Documents

### 2.1 ASTM Standards:

- D 76 Specification for Tensile Testing Machines for Textiles<sup>2</sup>
- D 123 Terminology Relating to Textiles<sup>3</sup>
- D 1776 Practice for Conditioning and Testing Textiles<sup>3</sup>
- D 4848 Terminology for Force, Deformation and Related Properties of Textiles<sup>3</sup>
- D 4850 Terminology Relating to Fabric<sup>3</sup>

## 3. Terminology

3.1 For definitions of terms related to force and deformation used in this test method, refer to Terminology D 4848. For definitions of other terms related to textiles used in this standard, refer to Terminology D 123, and D 4850.

## 4. Summary of Test Method

4.1 A specimen is clamped in a tensile testing machine and extended to rupture. The breaking force is determined from a force-elongation curve or with an interfaced computer. Elongation is determined by calculating the difference between bench marks before the application of a force and at a specified force.

## 5. Significance and Use

5.1 This test method can be used for acceptance testing of commercial shipments but comparisons should be made with caution because estimates of between-laboratory precision are incomplete.

5.1.1 If there are differences of practical significance between reported test results for two laboratories (or more), comparative tests should be performed to determine if there is a statistical bias between them, using competent statistical assistance. As a minimum, use samples for such comparative tests that are as homogeneous as possible, drawn from the same lot of material as the samples that resulted in disparate results during initial testing, and randomly assigned in equal numbers to each laboratory. The test results from the laboratories involved should be compared using a statistical test for unpaired data, at a probability level chosen prior to the testing series. If bias is found, either its cause must be found and corrected, or future test results for that material must be adjusted in consideration of the known bias.

5.2 Elongation is an indication of the ability of a fiber to absorb energy. The elongation of textile materials must be great enough to withstand strains experienced in processing and end use, and to absorb the energies of applied forces repeatedly.

## 6. Apparatus<sup>4</sup>

6.1 *Tensile Testing Machine*, CRE-type, conforming to Specification D 76 with respect to force indication, working range, capacity and verification of recorded elongation, and designed for operation at a pulling speed of  $75 \pm 25$  mm/min ( $3 \pm 1$  in./min).

<sup>1</sup> This test method is under the jurisdiction of ASTM Committee D13 on Textiles and is the direct responsibility of Subcommittee D13.60 on Fabric Test Methods, Specific.

Current edition approved April 10, 2002. Published August 2002.

<sup>2</sup> *Annual Book of ASTM Standards*, Vol 07.01.

<sup>3</sup> *Annual Book of ASTM Standards*, Vol 07.02.

<sup>4</sup> Apparatus and clamps are commercially available.

6.2 *Clamping Assembly*, consisting of an upper and lower clamp, each a split-drum type, as shown in Fig. 1 and Fig. 2.

6.3 *Computer or Microprocessor*, interfaced, with automatic data gathering system, including photo or electronic instruments to measure elongation. (Optional.)

## 7. Sampling, Test Specimens, and Test Units

7.1 *Lot Sample*—Take a lot sample as directed in the applicable material specification. In absence of such a specification randomly select five rolls or pieces to constitute the lot sample.

7.2 *Laboratory Sampling Unit, as produced material*—As a laboratory sampling unit take one piece of full-width webbing, tape or braid that is at least 1.4 m (1.5 yd) in length from each roll or piece in the lot sample.

7.2.1 For thick specimens, longer specimens may be required to maintain the specified gage length and to ensure the specimen is completely in the clamps.

7.2.2 When testing after abrasion is required, as a laboratory sampling unit, take one piece of full-width webbing, tape or braid that is at least 2.8 m (3.0 yd) in length from each roll or piece in the lot sample (see 7.2.1).

7.3 *Test Specimens, as produced material*—From each laboratory sampling unit, cut 1 test specimen full-width and at least 1.4 m (1.5 yd) in length (see 7.2.1).

7.3.1 When testing after abrasion is required, from each laboratory sampling unit, cut 2 test specimens full width and at least 1.4 m (1.5 yd) in length (see 7.2.1). Mark one specimen “A” for abraded and the other “U” for unabraded.

7.4 When the lot or shipment consist of less than 5 rolls or pieces, randomly select 5 test specimens for each condition of test, that represent all rolls or pieces in the lot or shipment.

7.5 Ensure specimens are free of folds, creases, or wrinkles. Avoid getting oil, water, grease, etc. on the specimens when handling.

NOTE 1—An adequate specification or other agreement between the purchaser and the supplier requires taking into account the variability between shipping units, between packages or ends within a shipping unit, and between specimens from a single package to provide a sampling with a meaningful producer’s risk, consumer’s risk, acceptable quality level and limiting quality level.

## 8. Preparation of Apparatus

8.1 Prepare and verify the calibration of the tensile testing machine as directed in the manufacturer’s instructions and Specification D 76.

8.2 Set up and adjust the CRE-type tensile testing machine as follows:

8.2.1 Ensure that the clamps are positioned such that they are facing opposite of each other with the upper clamp facing front and the lower clamp facing back. Set the distance between clamps, (gage length) to  $250 \pm 10$  mm ( $10 \pm 0.5$  in.), center to center of the drums at the split.

8.2.2 Use a force measuring system such that the breaking force will fall between 15 and 85 percent of its full-scale capacity.

8.2.3 Set the crosshead speed to  $75 \pm 25$  mm/min ( $3 \pm 1$  in./min).

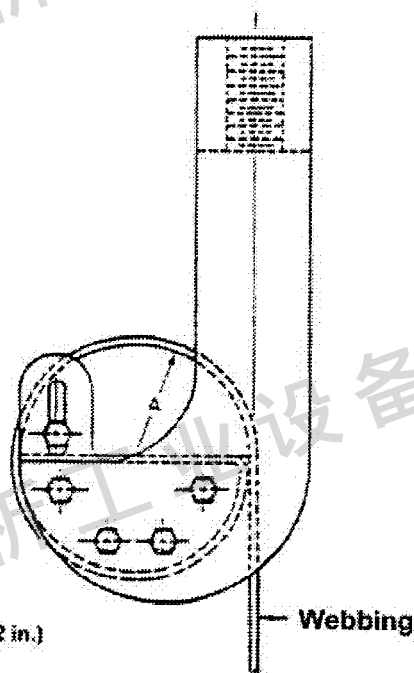

TEST JAWS FOR HIGH STRENGTH TEXTILES

FIG. 1 Side View of Clamping Assembly

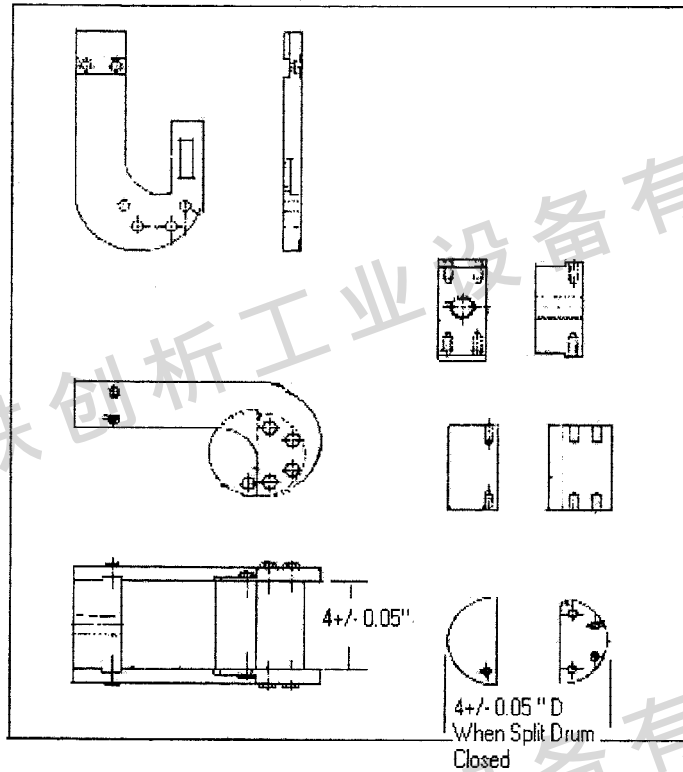

FIG. 2 Example of Clamping Assembly

8.2.4 When using an interfaced computer or microprocessor, set parameters to obtain selected properties using supplier's directions and Specification D 76.

## 9. Conditioning

9.1 Condition the test specimens to moisture equilibrium for testing in the standard atmosphere for testing textiles in accordance with Practice D 1776 or, if applicable, in the specified atmosphere in which the testing is to be performed.

9.2 In the event of dispute concerning the results of tests that may be affected by the moisture content, test specimen(s) shall be preconditioned by bringing them to approximate moisture equilibrium in the standard atmosphere for preconditioning textiles in accordance with Practice D 1776.

## 10. Procedure

10.1 Test the relaxed specimens in the standard atmosphere for testing textiles.

NOTE 2—The force measuring system should be zeroed prior to running any specimens and periodically during the course of the test, particularly if drift is observed in the zero value of the force measuring system.

10.2 Insert one end of the specimen centrally and completely between the two halves of the split drum in the upper clamp. From the front of the drum, wrap the specimen down and around the back of the lower half of the drum and up around the upper half, such that the specimen comes over the upper clamp front.

10.3 Take the opposite end of the specimen and starting at the back, loosely wrap around both halves of the lower clamp.

From the back of the lower clamp, lift the upper half of the split drum and insert the specimen end centrally and completely between the two halves of the split drum. Remove as much slack from the specimen as possible.

10.3.1 When elongation is required and a slight tension is specified in a material specification, apply the tension by moving the lower crosshead (pulling mechanism) down until the specified tension is shown on the recording device.

10.4 When elongation is required, set the photo or electronic instruments as directed in the manufacturer's directions, if used, or place two fine ink bench marks such that the distance between them is  $125 \pm 1$  mm ( $5 \pm 0.05$  in.) apart. Ensure neither bench mark is closer than 40 mm (1.5 in.) to either clamp.

10.5 Start the tester.

10.6 When elongation is required, determine on the same specimen as used for breaking strength. Stop the tester at the specified force, determine the percent elongation from the photo or electronic instruments, if used, or measure and record the distance between bench marks to the nearest 1 mm (0.05 in.). Restart the tester and immediately stop and record the breaking force when the specimen ruptures.

10.7 If the specimen breaks within 6 mm (0.25 in.) of the nip of either clamp edge, or slippage is indicated by a leveling in the force direction with abnormally high elongation, or for any reason attributable to faulty technique an individual measurement falls 20 % below the average test result for the lot, discard the result and test another specimen from the same package.

10.8 Remove the specimen from the tester and continue testing until all specimens have been tested for each laboratory sampling unit and for the lot.

## 11. Calculation or Interpretation of Results

11.1 *Breaking Force*—Calculate the breaking force for individual specimens as read directly from the testing machine force indicator to the nearest 1 %.

11.1.1 Calculate the average breaking strength to the nearest 1 % for the lot using the individual breaking force determinations.

11.2 When specified, calculate the percent elongation at specified force (EASF) for each specimen to the nearest 1.0 % using Eq 1.

$$EASF = (100) \frac{A}{B} \quad (1)$$

where:

*EASF* = elongation at specified force, %,

*A* = initial nominal length between bench marks, 125 mm (5 in.), and

*B* = length between bench marks at a specified force, mm (in.).

11.2.1 Calculate the average percent elongation at specified force (EASF) for the lot using individual elongation determinations at specified force determinations.

11.3 *Computer-Processed Data*—When data is automatically computer processed, calculations are generally contained in the associated software and the results displayed or printed, or both. In any event, it is recommended that the computer-processed data be verified against known property values and that the software be described in the report.

## 12. Report

12.1 State that the tests were made as directed in Test Method D 6775. Describe the material or product tested and the method of sampling used.

12.2 Report the following information for each laboratory sampling unit and for the lot:

12.2.1 Individual breaking force,

12.2.2 Average breaking strength,

12.2.3 When required, individual elongation at specified force,

12.2.4 When required, average elongation at specified force, and

12.2.5 For computer-processed data, identify the program (software) used.

## 13. Precision and Bias

13.1 *Summary*—Based upon limited information from one laboratory, the single-operator and within-laboratory components of variation and critical differences shown in Tables 1 and 2 are approximate. These tables are constructed to illustrate what one laboratory found when all the observations are taken by well-trained operators using the same piece of equipment and specimens randomly drawn from the sample of material. For this laboratory, in comparing two averages, the differences should not exceed the single-operator precision values shown in Table 2 for the respective number of tests in 95 out of 100

**TABLE 1 Breaking Strength of MIL-W4088 Class 1, Type VIII Webbing (Components of Variance Expressed as Standard Deviations<sup>A</sup>)**

Component of Variance	
Grand Average, lb	4668
Single-Operator Component	71
Within-Operator Component	0

<sup>A</sup> The square roots of the components of variance are being reported to express the variability in the appropriate units of measure rather than as the squares of those units of measure.

**TABLE 2 Breaking Strength of MIL-W4088 Class 1, Type VIII Webbing (Critical Differences for the Conditions Noted<sup>A</sup>)**

Material	Number of Observations in Each Average	Single-Operator Precision	Within-Laboratory Precision
MIL-W4088 Class 1, Type VIII Webbing	1	198	198
	2	140	140
	5	88	88
	10	63	63

<sup>A</sup> The critical differences were calculated using  $t = 1.960$ , which is based on infinite degrees of freedom.

cases. Differences for other laboratories may be larger or smaller.

13.2 *Single-laboratory Test Data*—A single-laboratory test was run in 2000 in which randomly-drawn samples of one material was tested. Six operators performed breaking strength tests in the laboratory. Each operator tested five sets of specimens, each set consisted of five specimens for a total of 25 determinations. The tests were conducted over a two-week period using the breaking strength procedure outlined in this test method. Analysis of the data was conducted using the adjunct “Tex-Pac.” The components of variance for breaking strength expressed as standard deviations were calculated to be the values listed in Table 1. The material was MIL-W-4088 Class 1, Type VIII, BRM Lot 946616 Webbing.

13.3 *Precision*—Because tests were conducted in only one laboratory, estimates of between laboratory precision have not been determined. Before a meaningful statement can be made about two specific laboratories, the amount of statistical bias, if any, between them must be established, with each comparison being based on recent data obtained on specimens taken from a lot of material of the type being evaluated so as to be as nearly homogeneous as possible and then randomly assigned in equal numbers to each of the laboratories. However when agreed upon between the contractual parties, for the approximate components of variance reported in Table 1, two averages of observed values may be considered significantly different at the 95 % probability level if the difference equals or exceeds the critical differences listed in Table 2, for breaking strength of webbing material.

NOTE 3—Because the intralaboratory test included less than the recommended five laboratories, estimates of precision data in Tables 1 and 2 may be either underestimated or overestimated to a considerable extent and should be used with special caution.

13.4 *Bias*—The procedure of this test method produces a test value that can be defined only in terms of a test method. There is no independent, referee method by which bias may be determined. This test method has no known bias.

## 14. Keywords

fied force; tape; webbing

### 14.1 braided fabric; breaking strength; elongation at speci-

*ASTM International takes no position respecting the validity of any patent rights asserted in connection with any item mentioned in this standard. Users of this standard are expressly advised that determination of the validity of any such patent rights, and the risk of infringement of such rights, are entirely their own responsibility.*

*This standard is subject to revision at any time by the responsible technical committee and must be reviewed every five years and if not revised, either reapproved or withdrawn. Your comments are invited either for revision of this standard or for additional standards and should be addressed to ASTM International Headquarters. Your comments will receive careful consideration at a meeting of the responsible technical committee, which you may attend. If you feel that your comments have not received a fair hearing you should make your views known to the ASTM Committee on Standards, at the address shown below.*

*This standard is copyrighted by ASTM International, 100 Barr Harbor Drive, PO Box C700, West Conshohocken, PA 19428-2959, United States. Individual reprints (single or multiple copies) of this standard may be obtained by contacting ASTM at the above address or at 610-832-9585 (phone), 610-832-9555 (fax), or [service@astm.org](mailto:service@astm.org) (e-mail); or through the ASTM website ([www.astm.org](http://www.astm.org)).*