



High Speed, Flexible Chip mounter

CP45FV/NEO

*Advanced Technology
Makes It All Possible !*



SAMSUNG TECHWIN CO., LTD.



Welcome to Samsung SMT Equipment

CP45-1

CONTENT



- 1. OVERVIEW**
- 2. FEATURE**
- 3. SYSTEM CONFIGURATION**
- 4. FEATURES OF EACH PART**
- 5. SPECIFICATION**





1. OVERVIEW

The CP45FV Neo is a high speed, flexible placement machine. With its unique technology it performs high speed mounting at 20,200 cph.

In addition it can place any type of components shown in the market ranging from tiny 0201 to large QFPs; from BGAs to fine pitch CSPs.

These characteristics of CP45FV provides you **One-Machine solution.**



2. FEATURE

SPEEDY

0.197sec/chip (13,000 CPH) ← Flying Vision Concept
(CP45FV Neo : 0.178sec/chip, 20,224 CPH)

FLEXIBLE

Wide component coverage of 0201~□ 42mm

RELIABLE

±0.04mm 3 sigma accuracy for fine pitch IC

CONVENIENT

Easy to use and various options for fast job change-over



3. SYSTEM CONFIGURATION



3.1 EXTERNAL APPEARANCE

**CP45neo :
LCD monitor**

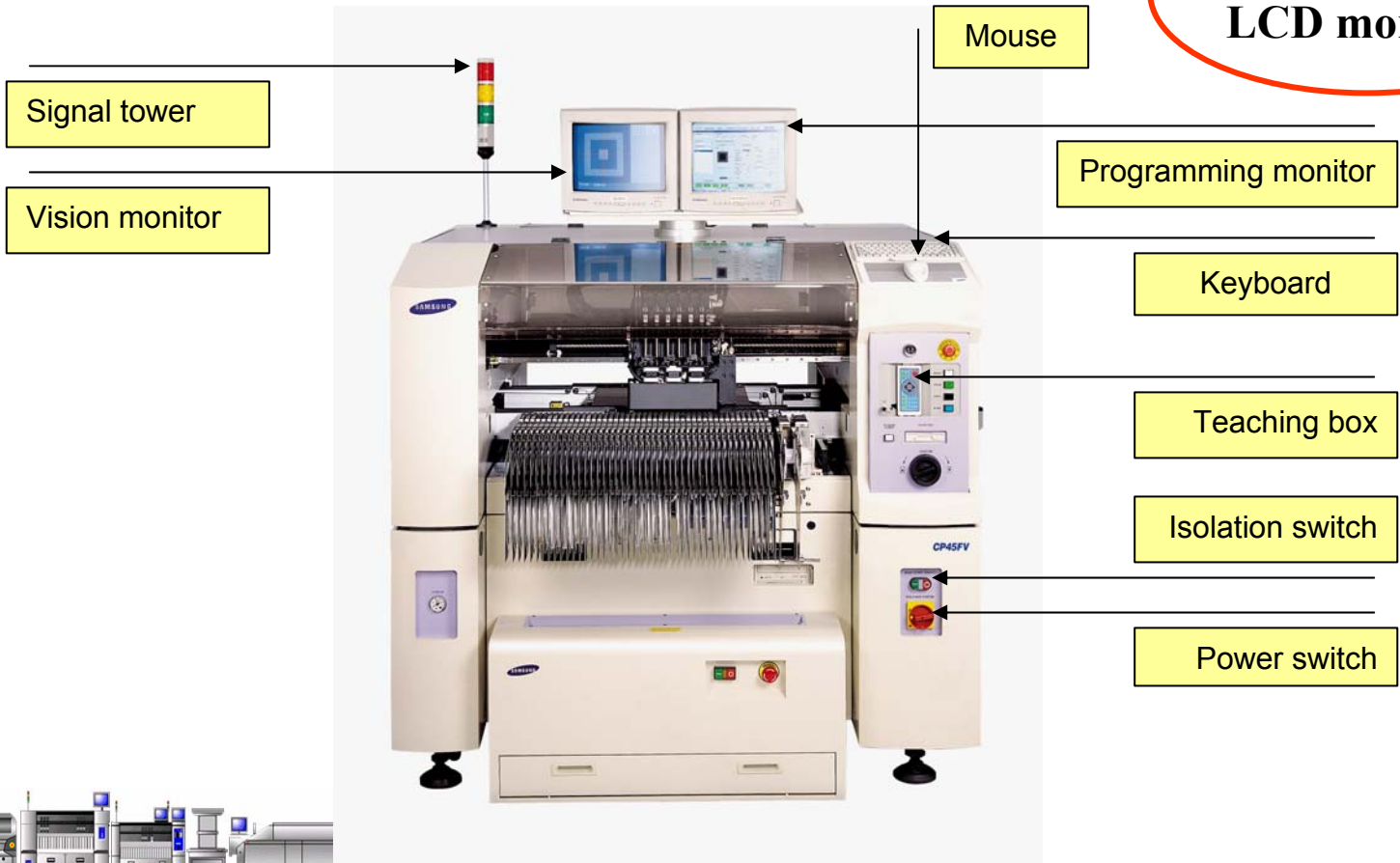

3.2 MECHANICAL STRUCTURE

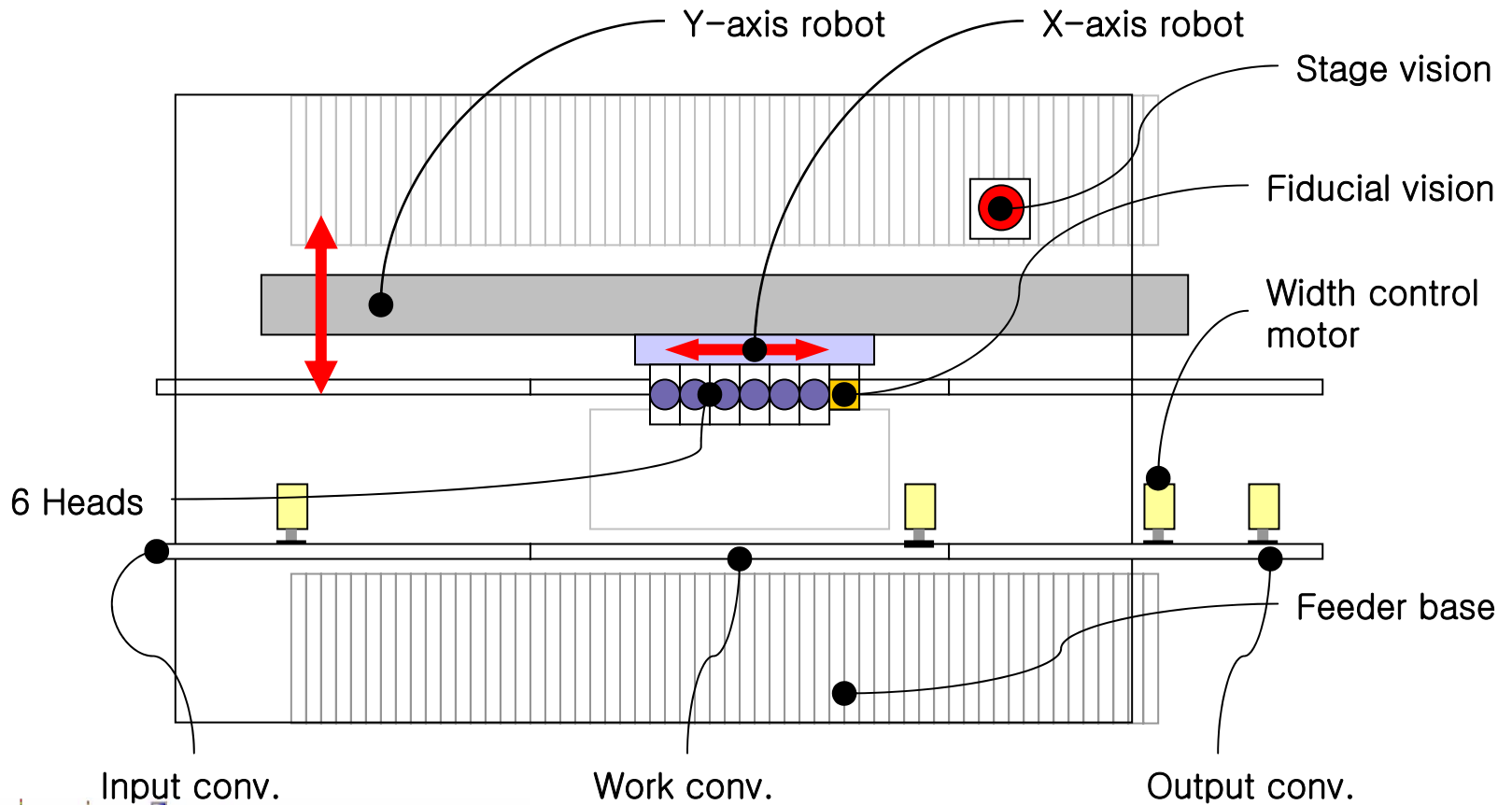

4. FEATURES OF EACH PART



4.1 HEAD

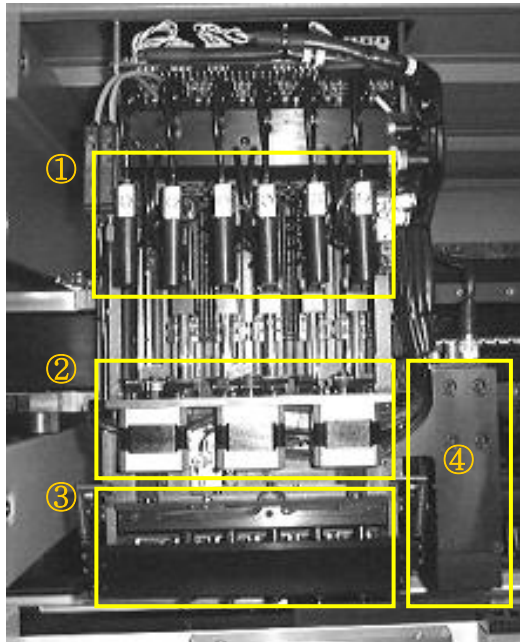

- SHSV Flying Vision Technology
- High speed & high accurate control of Z-motion with 6 servo motor
- On-the-fly vision recognition for max. □ 22mm IC, even CSP
- Placement rate at 14,900cph (IPC9850)

- ① : Vacuum Valve
- ② : Theta Axis Motor
- ③ : Flying Vision
- ④ : Fiducial Camera



FLYING VISION CONCEPT

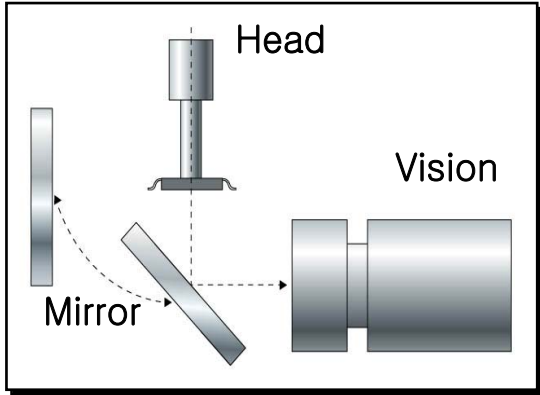

■ Design concept: Minimize machine travel distance

With the flying vision mechanism, components recognition can be done during the movement from pickup position to placement.

→ It removes the unnecessary machine movement which is needed in conventional fixed vision concept.

SEQUENCE

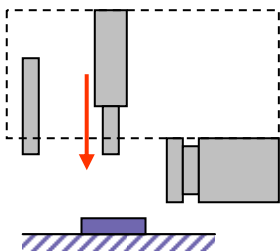

Z down

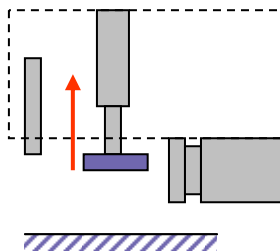

Pick up

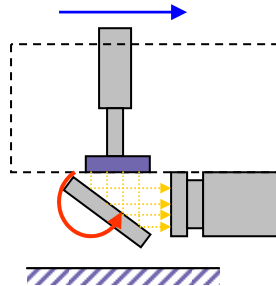

X-Y move & mirror swing (45°) & vision inspection

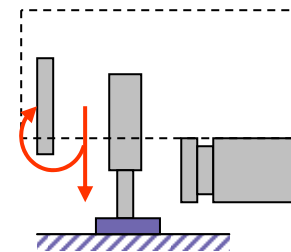

Mirror swing & placement



Flying vision vs. conventional Aligner

■ Laser Aligner

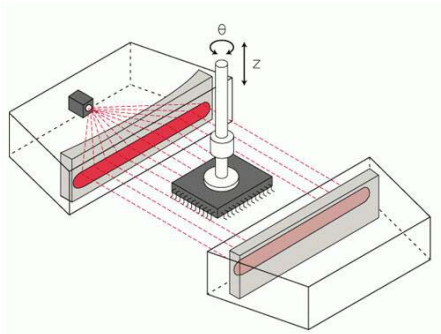

1. Recognize shadows of the image
2. Inspect side of the component



Can not be used for fine pitch IC, BGA or CSP



■ Flying Vision

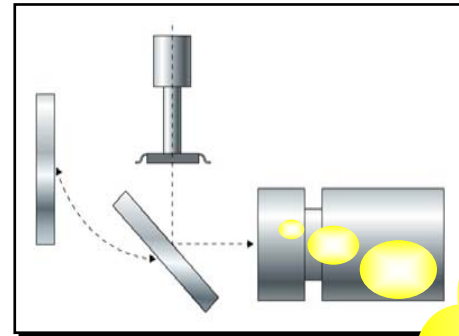

1. Recognize actual image
2. Inspect bottom of the component

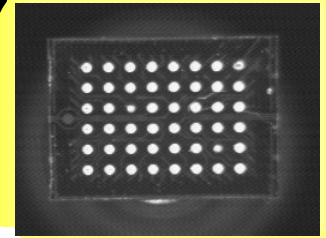

4.3 CONVEYOR SYSTEM

HEAD achieves High Performance and High Stability through

- *3-stage Conveyor System*
- *Belt Clamping System*

■ 3-stage conveyor system

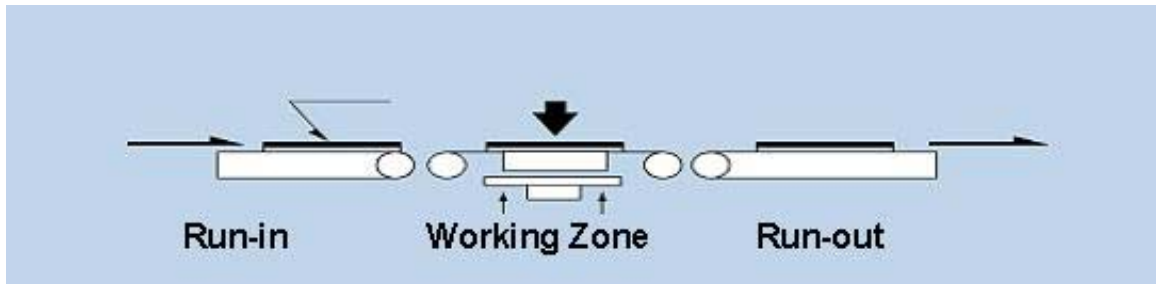

Control of acceleration and deceleration of PCB transferring speed by 3 individual motors

- PCB soft stop → preventing the shift of components
- Optimization of Conveying speed



■ Belt clamping system

- Zero PCB Flatness
- Auto Adjustment of clamping height
 - Optimization of PCB fixing status

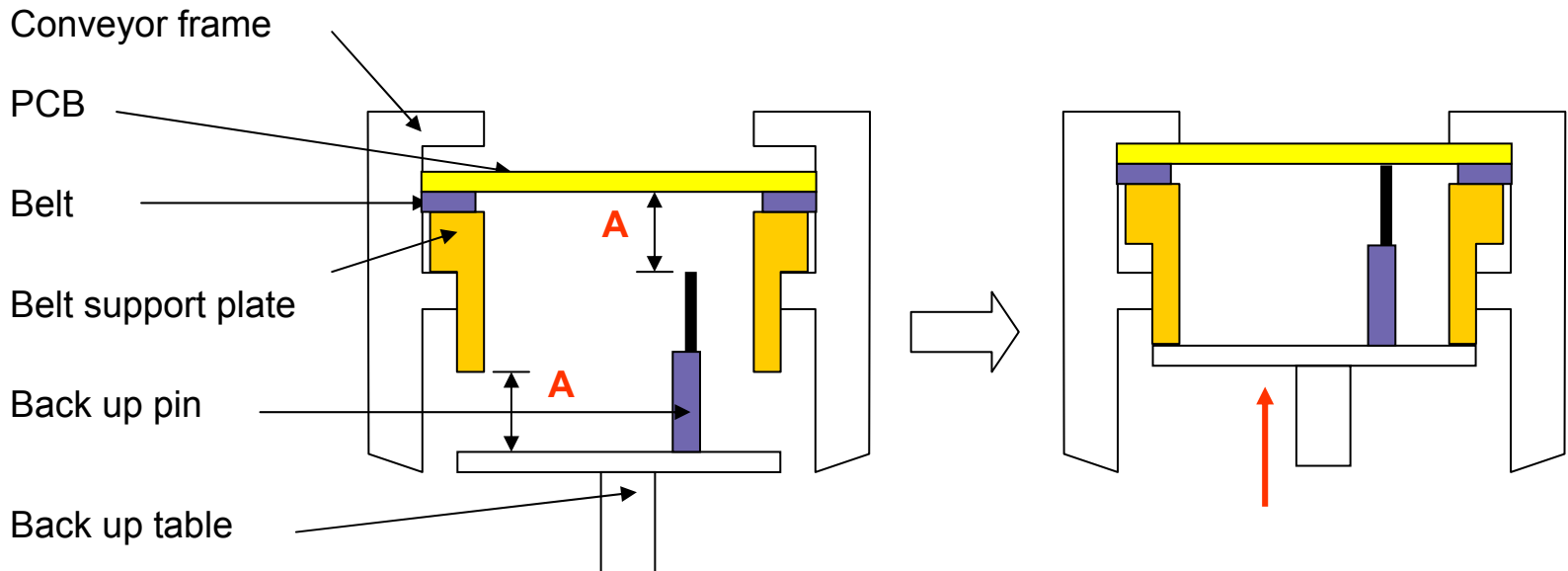

4.4 FRAME

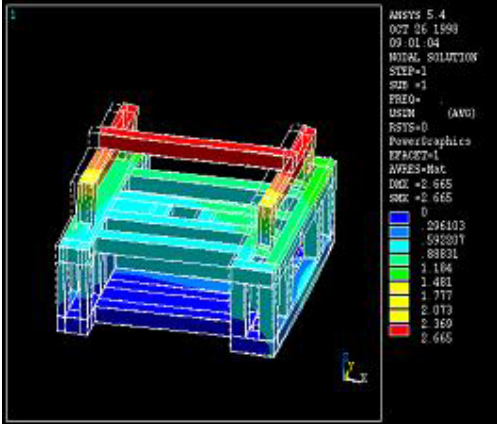

- **Low Weight & High Rigidity**
- Optimal Design by FEM analysis
- **Simplified Structure using modal analysis**
- **Optimized Servo Tuning**

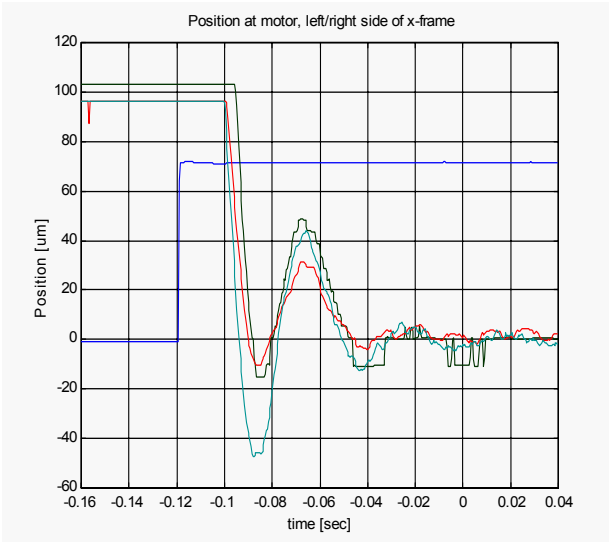
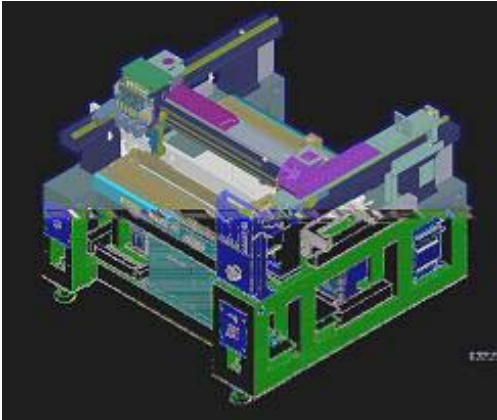

4.5 CONTROLLER



➤ **Dual CPU Structure**

- *Personal Computer for programming*
- *VME CPU for machine sequence control*

➤ **This structure makes it possible
: to program for the other model
during the system running.**

:to stabilize the system running.



4.6 VISION SYSTEM

SAMSUNG

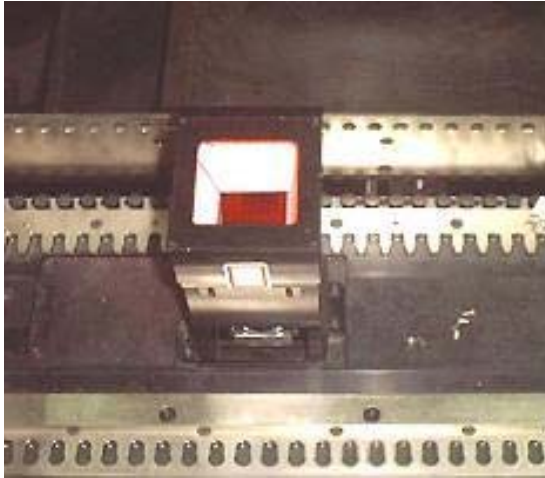

- **Enhanced Optic Design**
- **High Performance Vision Algorithm**
- **3-D Digital Illumination**
 - ❖ **Standard Components' DB for Easy Operating**

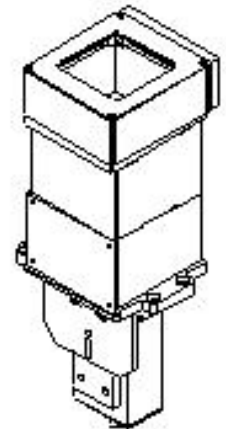

High Performance Vision Algorithm



- **High Speed Recognition**
 - Tact time : Less than 1.6sec/QFP
- **High Resolution**
 - 256 level gray scale image process
 - Up to 0.3mm pitch QFP, 0.5mm pitch uBGA

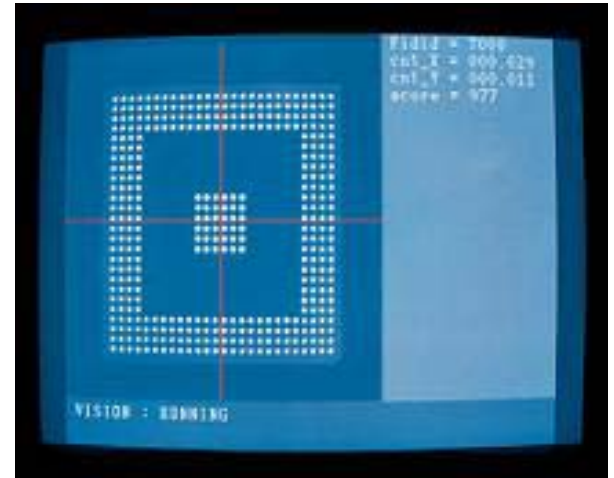

3D DIGITAL ILLUMINATION SYSTEM

SAMSUNG

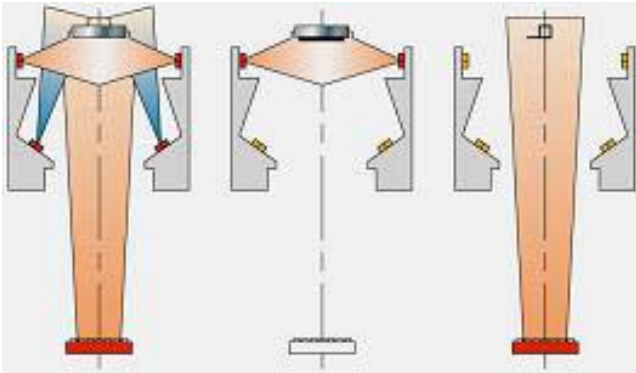

- **Advanced Multi-Light System**
: Special Design for Fine Pitch QFP, uBGA and CSP.
- **Individual brightness setting for each component is available**
- **Programmable light level: 16 steps**

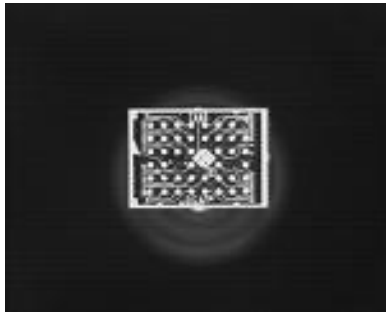

Ordinary Light

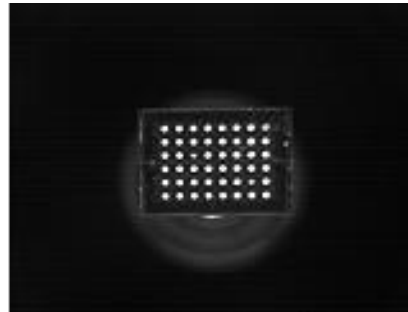

Samsung Unique Light



4.7 ANC

SAMSUNG



➤ **High Flexibility to cope with various Applications**

→ **37 nozzle Pockets**

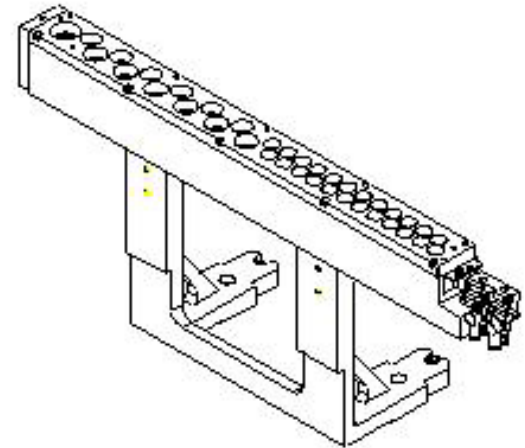

4.8 SOFTWARE

SAMSUNG

- Various Software for Easy Programming under User Friendly Environment
- Efficient Software for High Productivity and High Capacity due to Customer's Needs

- **User Friendly Environment**
 - Windows 98 based
 - Graphic User Interface
 - Multi-tasking
 - Easy use of Database
 - Network and Print features
 - Real-time Graphic Monitoring
- > **Simplified & Well organized Menu Tree Structure**



- **3D Animation Trouble Shooting Guide**
 - Well accumulated Service DB for Long Time
 - Well classified Service DB for Various Cases
 - Maximized Visual Effect
 - Easy Analysis and Repair of Error
- **Production Control System**
 - Save/Analysis feature regarding Production Management Data
 - Real time monitoring for various items
- **Optimizer**
 - Optimization of Chips Distribution
 - Optimization of Feeder Arrangement
 - Optimization of Mounting Sequence
 - > Shorter Calculation Time for Optimization
 - > Better Efficient Optimization

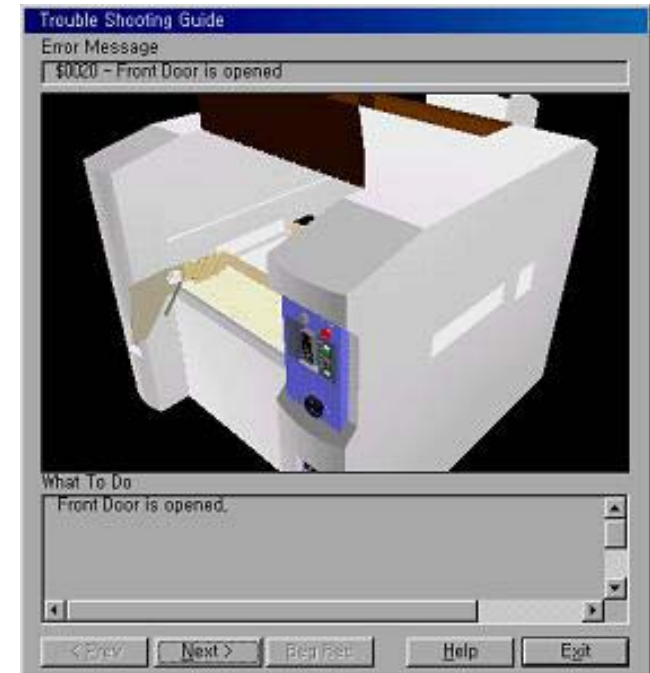

5. SPECIFICATION



5.1 GENERAL		
Alignment method		Full vision
Max. feeder capacity		104 ea
Head		6 ea
PCB Size	Min.	50mm x 50mm
	Max.	460mm x 400mm
	Thickness	0.38mm ~ 4.2mm



5. SPECIFICATION



5.2 SPEED

Flying vision	CHIP	CP45 18,900 CPH (0.197sec/chip) CP45Neo20,200 CPH (0.178 sec/chip)
	CHIP (IPC9850)	13,000 CPH/Standard 14,900 CPH/Neo
	SOP, QFP	0.75 sec/chip
Fixed vision	0.5mm pitch QFP	1.6 sec/IC



5.3 COMPONENT		
Flying vision	Component range	0201 ~ □ 22mm
	Min. lead pitch of QFP	0.5mm pitch
Fixed vision	Standard	~ □ 32mm (0.4 pitch) ~ □ 17mm (0.3 pitch)
	Option for large IC	~ □ 42mm (0.5 pitch) ~ □ 32mm (0.4 pitch)
	Option for CSP	~ □ 17mm (0.5 pitch)
Max. component height		15mm
Summary (standard)		0201 ~ □ 32mm Min. lead pitch: 0.3mm Min. ball pitch: 0.75mm
Summary (with option)		0201 ~ □ 42mm Min. lead pitch: 0.3mm Min. ball pitch: 0.5mm



5. SPECIFICATION



5.4 E.T.C.	
Length	1,660 mm
Width	1,540 mm
ANC pocket	37 holes
Standard nozzle types	7 types
MMI	Windows based
Z-motion control	6 servo motors
Theta motion control	3 micro stepping motors
Conveyor width control	Automatic
Conveyor system	3-stage



5. SPECIFICATION



5.5 Sales Point	
14,900 cph (IPC 9850)	New servo motor (improved 3 times & sequence optimization)
55 x 55 mm	MFOV (option)
510 x 460 mm PCB	Large Board (Option)
Cushion Nozzle (the same of CP60 series)	No damage on the components, less noise
Components counting	Provide the remaining number of the components on the reel
Body machines	LCD Monitor, New cover
Tray feeder	Shuttle tray feeder
Non-stop Feeder available	
Max Height	Flying vision : 9 mm Stage vision : 15 mm

