

HDO Series

Precision compensated pressure sensors

FEATURES

- 10 mbar to 5 bar, absolute, gage or differential pressure
- Calibrated and temperature compensated
- High impedance for low power applications
- Small SMD packages
- RoHS compliant

MEDIA COMPATIBILITY

To be used with non-corrosive, non-ionic working fluids such as clean dry air, dry gases and the like.



SPECIFICATIONS

Maximum ratings

Supply voltage V_s +20 V_{DC}

Lead specifications

Average preheating temperature gradient 2.5 K/s
Soak time ca. 3 min
Time above 217°C 50 s
Time above 230°C 40 s
Time above 250°C 15 s
Peak temperature 260°C
Cooling temperature gradient -3.5 K/s

Temperature ranges

Compensated 0 ... 50 °C
(0 ... 70 °C on request)

Operating -40 ... 85 °C

Storage -40 ... 125 °C

Humidity limits (non-condensing) 0 ... 100% RH

EQUIVALENT CIRCUIT

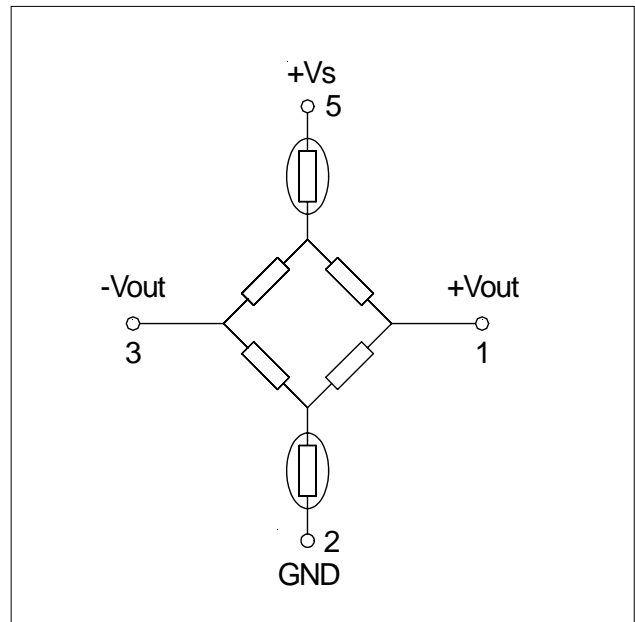

HDO Series

Precision compensated pressure sensors

PRESSURE RANGES SPECIFICATIONS¹

Part number	Operating pressure	Proof pressure ¹¹	Burst pressure ¹²	Full-scale span ²		
				Min.	Typ.	Max.
HDOM010...P	0...10 mbar	100 mbar	150 mbar	19.7 mV	20.0 mV	20.3 mV
HDOM020...P	0...20 mbar	100 mbar	150 mbar	24.7 mV	25.0 mV	25.3 mV
HDOM050...P	0...50 mbar	250 mbar	500 mbar	19.7 mV	20.0 mV	20.3 mV
HDOM100...P	0...100 mbar	250 mbar	500 mbar	19.7 mV	20.0 mV	20.3 mV
HDOM200...P	0...200 mbar	1 bar	1.4 bar	29.7 mV	30.0 mV	30.3 mV
HDOM500...P	0...500 mbar	1 bar	1.4 bar	29.7 mV	30.0 mV	30.3 mV
HDOB001A...P	0...1 bara	3 bara	5 bara	89.1 mV	90.0 mV	90.9 mV
HDOB001(D,G)...P	0...1 bar	3 bar	5 bar	59.4 mV	60.0 mV	60.6 mV
HDOB002...P	0...2 bar	4 bar	6 bar	49.5 mV	50.0 mV	50.5 mV
HDOB005...P	0...5 bar	7 bar	7 bar	59.4 mV	60.0 mV	60.6 mV
HDOM010...H	0...10 mbar	100 mbar	150 mbar	19.5 mV	20.0 mV	20.5 mV
HDOM020...H	0...20 mbar	100 mbar	150 mbar	24.5 mV	25.0 mV	25.5 mV
HDOM050...H	0...50 mbar	250 mbar	500 mbar	19.37 mV	20.0 mV	20.63 mV
HDOM100...H	0...100 mbar	250 mbar	500 mbar	19.37 mV	20.0 mV	20.63 mV
HDOM200...H	0...200 mbar	1 bar	1.4 bar	28.95 mV	30.0 mV	31.05 mV
HDOM500...H	0...500 mbar	1 bar	1.4 bar	28.95 mV	30.0 mV	31.05 mV
HDOB001A...H	0...1 bara	3 bara	5 bara	86.85 mV	90.0 mV	93.15 mV
HDOB001(D,G)...H	0...1 bar	3 bar	5 bar	57.9 mV	60.0 mV	62.1 mV
HDOB002...H	0...2 bar	4 bar	6 bar	48.25 mV	50.0 mV	51.75 mV
HDOB005...H	0...5 bar	7 bar	7 bar	57.9 mV	60.0 mV	62.1 mV

Specification notes:

1. Reference conditions: supply voltage, $V_s=12 V_{DC}$; $T_A=25^\circ C$; RH=50 %; common mode line pressure = 0 bar; pressure applied to high pressure port.
2. Span is the algebraic difference between the output voltage at full scale pressure and the output at zero pressure. Span is ratiometric to the supply voltage.
3. Hysteresis is the maximum output difference at any point within the operating pressure range for increasing and decreasing pressure.
4. Maximum error band of the offset voltage and the error band of the span, relative to the 25°C reading.
5. Maximum difference in offset respectively maximum difference in span within the temperature range of 0...+50°C after:
 - a) 100 temperature cycles, 0...+50°C.
 - b) 1.0 million pressure cycles, 0 psi to full scale span.
6. Input impedance is the impedance between V_s and ground.
7. Output impedance is the impedance between + and - outputs.
8. This is the common mode voltage of the output arms for $V_s = 12 V_{DC}$.
9. Response time for a zero to full scale span pressure step change, 10 to 90 % rise time.
10. Long term stability over a one year period.
11. Proof pressure is the maximum pressure which may be applied without causing durable shifts of the electrical parameters of the sensing element.
12. Burst pressure is the maximum pressure which may be applied without causing damage to the sensing element or leaks to the housing.

HDO Series

Precision compensated pressure sensors

PERFORMANCE CHARACTERISTICS¹

All HDO...P devices (Prime Grade)

Characteristics		Min.	Typ.	Max.	Unit
Zero pressure offset		-0.25	0	+0.25	mV
Combined linearity and hysteresis ³			±0.1	±0.25	%FSO
Temperature effects (0...50 °C) ⁴	Offset		±0.2	±0.5	mV
	Span		±0.4	±1.0	%FSO
Repeatability ⁵			±0.2	±0.5	
Input impedance ⁶	devices from 4 bar		>4		kΩ
	all other devices		>12		
Output impedance ⁷			4.0		
Common mode voltage ⁸		4.8	6.0	7.2	V _{DC}
Response time ⁹			100		μsec
Long term stability of offset and span ¹⁰			±0.1		mV

All HDO...H devices (High Grade)

Characteristics		Min.	Typ.	Max.	Unit
Zero pressure offset	devices up to 20 mbar	-0.75	0	+0.75	mV
	all other devices	-0.5	0	+0.5	
Combined linearity and hysteresis ³			±0.2	±1.0	%FSO
Temperature effects (0...50 °C) ⁴	Offset		±0.2	±1.0	mV
	Span		±0.4	±2.0	%FSO
Repeatability ⁵			±0.2	±0.5	
Input impedance ⁶	devices from 4 bar		>4		kΩ
	all other devices		>12		
Output impedance ⁷			4.0		
Common mode voltage ⁸		4.8	6.0	7.2	V _{DC}
Response time ⁹			100		μsec
Long term stability of offset and span ¹⁰			±0.1		mV

HDO Series

Precision compensated pressure sensors

PHYSICAL DIMENSIONS AND ELECTRICAL CONNECTIONS

Different housing options are available on request. Please contact First Sensor.

HDO...E... (SMD, 2 ports same side)

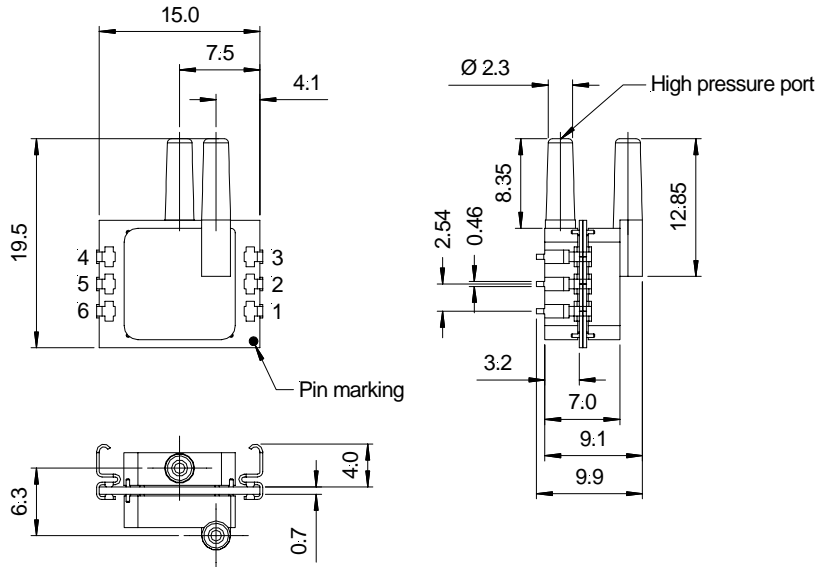

Pin	Connection
1	+Vout
2	GND
3	-Vout
4	I / C*
5	+Vs
6	I / C*

* Internal connection. Do not connect for any reason

Note:
The polarity indicated is for pressure applied to high pressure port (forward gage).

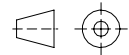

first angle projection
dimensions in mm

HDO...Y... (SMD, 1 port axial)

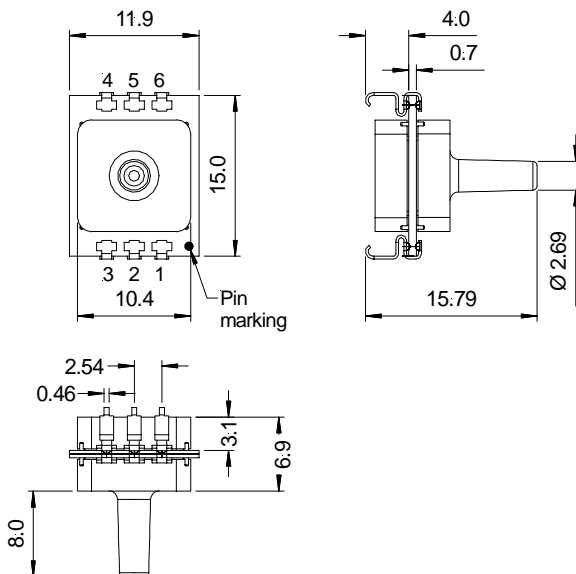

Pin	Connection
1	+Vout
2	GND
3	-Vout
4	I / C*
5	+Vs
6	I / C*

* Internal connection. Do not connect for any reason

Note:
Pressure port is in forward gage configuration

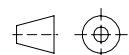

first angle projection
dimensions in mm

HDO Series

Precision compensated pressure sensors

ORDERING INFORMATION

Options	Series	Pressure range		Pressure mode		Housing		Porting		Grade	
	HDO	M010	10 mbar	A*	Absolute	E*	SMD, 2 ports same side	8	Straight	H	High
		M020	20 mbar	D	Differential					P	Prime
		M050	50 mbar	G	Gage	Y**	SMD, 1 port axial				
		M100	100 mbar								
		M200	200 mbar								
		M500	500 mbar								
		B001	1 bar								
		(B001A)	1 bara								
		B002	2 bar								
		B005	5 bar								
				* only available from 1 bar		* standard for differential devices, "D"					
						** standard for absolute and gage devices, "A" and "G"					
Example:	HDO	M100		D		E		8		P	

Note: Not all possible sensor configurations are active products. MOQ may apply.

Custom specific pressure ranges and mechanical or electronic sensor modifications are widely available. Please contact First Sensor for further information.

First Sensor reserves the right to make changes to any products herein. First Sensor does not assume any liability arising out of the application or use of any product or circuit described herein, neither does it convey any license under its patent rights nor the rights of others.