

LMI series – digital low differential pressure sensors

The LMI differential low pressure sensors are based on thermal flow measurement of gas through a micro-flow channel integrated within the sensor chip. The innovative LMI technology features superior sensitivity especially for ultra low pressures. The extremely low gas flow through the sensor ensures high immunity to dust contamination, humidity and long tubing compared to other flow-based pressure sensors.

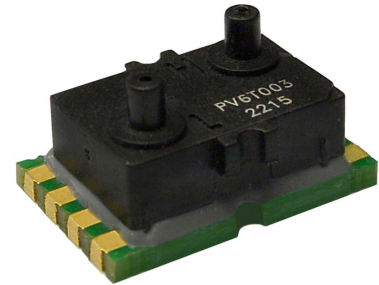

Features

- Ultra-low pressure ranges from 25 to 500 Pa (0.1 to 2 inH₂O), optional up to 2.5 kPa (10 inH₂O)
- Pressure sensor based on thermal micro-flow measurement
- High flow impedance
 - very low flow-through leakage
 - high immunity to dust and humidity
 - no loss in sensitivity using long tubing
- Outstanding long-term stability and precision with patented real-time offset compensation and linearization techniques
- Total accuracy better than 0.5% FS typical
- Two application-specific modes of operation
 - continuous mode (5 ms sampling time)
 - low power mode (400 µA standby current)
- Ideal for battery-operated applications
- Linearized digital I²C output with 16 bit sigma-delta A/D conversion
- Small footprint, low profile, only 9 mm in height, and robust package
- Pressure ports for direct manifold assemblies
- Highly versatile to fit to application-specific mounting adaptors and manifolds
- Minimized internal volume and manifold mount option allow for fast gas purge time

Certificates

- Quality Management System according to EN ISO 13485 and EN ISO 9001
- RoHS and REACH compliant

Media compatibility

Air and other non-corrosive gases

Applications

Medical

- Ventilators
- Spirometers
- CPAP
- Sleep diagnostic equipment
- Nebulizers
- Oxygen conservers/concentrators
- Insufflators/endoscopy

Industrial

- HVAC
 - VAV
 - Filter monitoring
 - Burner control
- Fuel cells
- Gas leak detection
- Fume hood
- Instrumentation
- Security systems

LMI series – digital low differential pressure sensors

Maximum ratings

Parameter	Min.	Max.	Unit
Supply voltage V_s	2.7	3.6	V_{DC}
Lead specifications			
Average preheating temperature gradient		2.5	K/s
Soak time		ca. 3	min
Time above 217 °C		50	s
Time above 230 °C		40	s
Time above 250 °C		15	s
Peak temperature		260	°C
Cooling temperature gradient		-3.5	K/s
Temperature ranges ⁽¹⁾			
Compensated	-20	+85	°C
Operating	-40	+85	°C
Storage	-40	+85	°C
Humidity limits (non-condensing)		97	%RH
Vibration ⁽²⁾		20	g
Mechanical shock ⁽³⁾		500	g

Pressure sensor characteristics

Part no.	Operating pressure	Proof pressure ⁽⁴⁾	Burst pressure ⁽⁴⁾
LMIS025U...	0...25 Pa / 0...0.25 mbar (0.1 inH ₂ O)		
LMIS050U...	0...50 Pa / 0...0.5 mbar (0.2 inH ₂ O)		
LMIS100U...	0...100 Pa / 0...1 mbar (0.4 inH ₂ O)		
LMIS250U...	0...250 Pa / 0...2.5 mbar (1 inH ₂ O)		
LMIS500U...	0...500 Pa / 0...5 mbar (2 inH ₂ O)	2 bar (30 psi)	5 bar (75 psi)
LMIS025B...	0...±25 Pa / 0...±0.25 mbar (0.1 inH ₂ O)		
LMIS050B...	0...±50 Pa / 0...±0.5 mbar (0.2 inH ₂ O)		
LMIS100B...	0...±100 Pa / 0...±1 mbar (0.4 inH ₂ O)		
LMIS250B...	0...±250 Pa / 0...±2.5 mbar (1 inH ₂ O)		
LMIS500B...	0...±500 Pa / 0...±5 mbar (2 inH ₂ O)		

Gas correction factors ⁽⁵⁾

Gas type	Correction factor
Dry air	1.0
Oxygen (O ₂)	1.07
Nitrogen (N ₂)	0.97
Argon (Ar)	0.98
Carbon dioxide (CO ₂)	0.56

Specification notes

- (1) For temperature ranges above 85 °C please contact First Sensor.
- (2) Sweep 20 to 2000 Hz, 8 min, 4 cycles per axis, MIL-STD-883, Method 2007.
- (3) 5 shocks, 3 axes, MIL-STD-883E, Method 2002.4.
- (4) The max. common mode pressure is 5 bar.

- (5) For example with a LMIS500... sensor measuring CO₂ gas, at full-scale output the actual pressure will be:

$$\Delta P_{\text{eff}} = \Delta P_{\text{Sensor}} \times \text{gas correction factor} = 500 \text{ Pa} \times 0.56 = 280 \text{ Pa}$$

ΔP_{eff} = True differential pressure,

ΔP_{Sensor} = Differential pressure as indicated by output signal

LMI series – digital low differential pressure sensors

Performance characteristics ⁽⁶⁾

($V_S = 3.3 V_{DC}$, $T_A = 20\text{ °C}$, $P_{Abs} = 1\text{ bara}$, calibrated in air, output signal is non-ratiometric to V_S)

Parameter	Min.	Typ.	Max.	Unit
Current consumption		Continuous mode	3.5	4.5
		Low-power mode	3.5	4.5
		active	0.4	0.75
		sleep		
Response time (t_{93})		5		ms
Power-on time			25	

25 Pa devices

Parameter	Min.	Typ.	Max.	Unit
Scale factor ⁽⁸⁾	0...25/0...±25 Pa	1200		counts/Pa
Noise level		±0.01		Pa
Offset warm-up shift			less than noise	
Offset long term stability ⁽⁷⁾		±0.05		Pa/year
Offset repeatability		±0.01		Pa
Span repeatability ^(9, 10)		±0.25		% of reading
Zero pressure offset accuracy ⁽⁹⁾		±0.04	±0.1	Pa
Span accuracy ^(9, 10)		±0.75	±1.5	% of reading
Thermal effects (-20...85 °C)	Offset		±0.1	Pa
	Span	±0.2	±0.5	% of reading per 10 °C

50 Pa devices

Parameter	Min.	Typ.	Max.	Unit
Scale factor ⁽⁸⁾	0...50/0...±50 Pa	600		counts/Pa
Noise level		±0.01		Pa
Offset warm-up shift			less than noise	
Offset long term stability ⁽⁷⁾		±0.05		Pa/year
Offset repeatability		±0.01		Pa
Span repeatability ^(9, 10)		±0.25		% of reading
Zero pressure offset accuracy ⁽⁹⁾		±0.04	±0.1	Pa
Span accuracy ^(9, 10)		±0.75	±1.5	% of reading
Thermal effects (-20...85 °C)	Offset		±0.2	Pa
	Span	±0.2	±0.5	% of reading per 10 °C

Specification notes (cont.)

(6) The sensor is calibrated with a common mode pressure of 1 bar absolute. Due to the mass flow based measuring principle, variations in absolute common mode pressure need to be compensated according to the following formula:

$$\Delta P_{\text{eff}} = \Delta P_{\text{Sensor}} \times 1 \text{ bara} / P_{\text{abs}}$$

ΔP_{eff} = True differential pressure,

ΔP_{Sensor} = Differential pressure as indicated by output voltage,

P_{abs} = Current absolute common mode pressure)

- (7) Figure based on accelerated lifetime test of 1000 hours at 85 °C biased burn-in.
 (8) The digital output signal is a signed, two complement integer. Negative pressures will result in a negative output
 (9) Zero pressure offset accuracy and span accuracy are uncorrelated uncertainties. They can be added according to the principles of error propagation.
 (10) Span accuracy below 10% of full scale is limited by the intrinsic noise of the sensor.

LMI series – digital low differential pressure sensors

Performance characteristics (cont.) ⁽⁶⁾

($V_S = 3.3 V_{DC}$, $T_A = 20\text{ °C}$, $P_{Abs} = 1\text{ bara}$, calibrated in air, output signal is non-ratiometric to V_S)

100 Pa devices

Parameter		Min.	Typ.	Max.	Unit
Scale factor ⁽⁸⁾	0...100/0...±100 Pa		300		counts/Pa
Noise level			±0.01		Pa
Offset warm-up shift				less than noise	
Offset long term stability ⁽⁷⁾			±0.05		Pa/year
Offset repeatability			±0.01		Pa
Span repeatability ^(9,10)			±0.25		% of reading
Zero pressure offset accuracy ⁽⁹⁾			±0.04	±0.1	Pa
Span accuracy ^(9,10)			±0.75	±1.5	% of reading
Thermal effects (-20...85 °C)	Offset			±0.2	Pa
	Span		±0.3	±0.5	% of reading per 10 °C

250 Pa devices

Parameter		Min.	Typ.	Max.	Unit
Scale factor ⁽⁸⁾	0...250/0...±250 Pa		120		counts/Pa
Noise level			±0.02		Pa
Offset warm-up shift				less than noise	
Offset long term stability ⁽⁷⁾			±0.05		Pa/year
Offset repeatability			±0.02		Pa
Span repeatability ^(9,10)			±0.25		% of reading
Zero pressure offset accuracy ⁽⁹⁾			±0.08	±0.25	Pa
Span accuracy ^(9,10)			±0.75	±1.5	% of reading
Thermal effects (-20...85 °C)	Offset			±0.5	Pa
	Span		±0.3	±0.5	% of reading per 10 °C

500 Pa devices

Parameter		Min.	Typ.	Max.	Unit
Scale factor ⁽⁸⁾	0...500/0...±500 Pa		60		counts/Pa
Noise level			±0.05		Pa
Offset warm-up shift				less than noise	
Offset long term stability ⁽⁷⁾			±0.05		Pa/year
Offset repeatability			±0.05		Pa
Span repeatability ^(9,10)			±0.25		% of reading
Zero pressure offset accuracy ⁽⁹⁾			±0.15	±0.5	Pa
Span accuracy ^(9,10)			±0.75	±1.5	% of reading
Thermal effects (-20...85 °C)	Offset			±1	Pa
	Span		±0.3	±0.5	% of reading per 10 °C

Specification notes (cont.)

(6) The sensor is calibrated with a common mode pressure of 1 bar absolute. Due to the mass flow based measuring principle, variations in absolute common mode pressure need to be compensated according to the following formula:

$$\Delta P_{\text{eff}} = \Delta P_{\text{Sensor}} \times 1 \text{ bara} / P_{\text{abs}}$$

ΔP_{eff} = True differential pressure,

ΔP_{Sensor} = Differential pressure as indicated by output voltage,

P_{abs} = Current absolute common mode pressure)

(7) Figure based on accelerated lifetime test of 1000 hours at 85 °C biased burn-in.

(8) The digital output signal is a signed, two complement integer. Negative pressures will result in a negative output

(9) Zero pressure offset accuracy and span accuracy are uncorrelated uncertainties. They can be added according to the principles of error propagation.

(10) Span accuracy below 10% of full scale is limited by the intrinsic noise of the sensor.

LMI series – digital low differential pressure sensors

Performance characteristics (cont.)

Total accuracy ⁽¹⁾

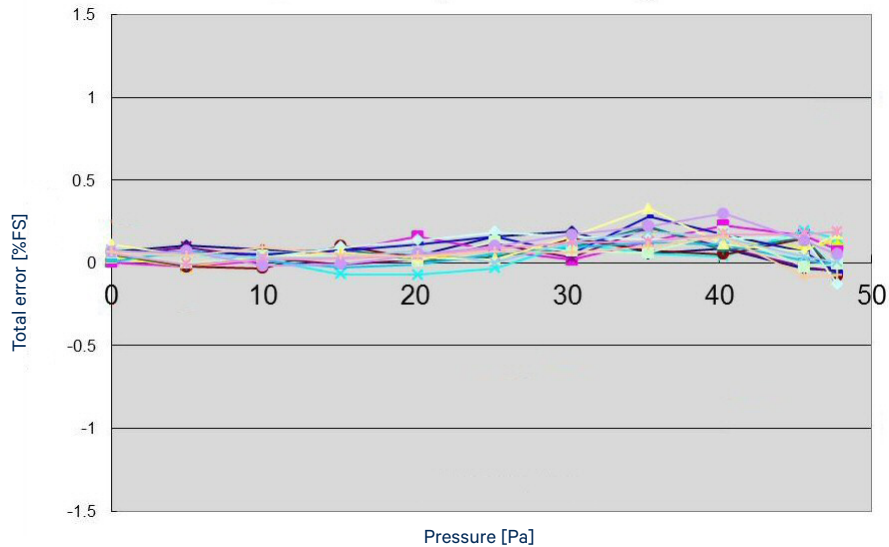

Fig. 1: Typical total accuracy plot of 16 LMI 50 Pa sensors @ 25 °C (typical total accuracy better than 0.5 %FS)

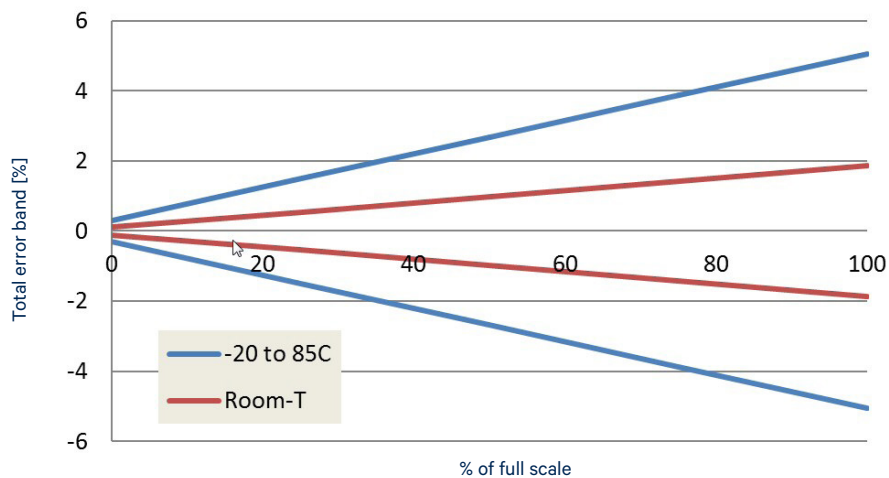

Fig. 2: Maximum total error band of 100/250/500Pa LMI sensors

Specification notes (cont.)

(1) Total accuracy is the combined error from offset and span calibration, non-linearity, repeatability and pressure hysteresis

LMI series – digital low differential pressure sensors

Noise plot

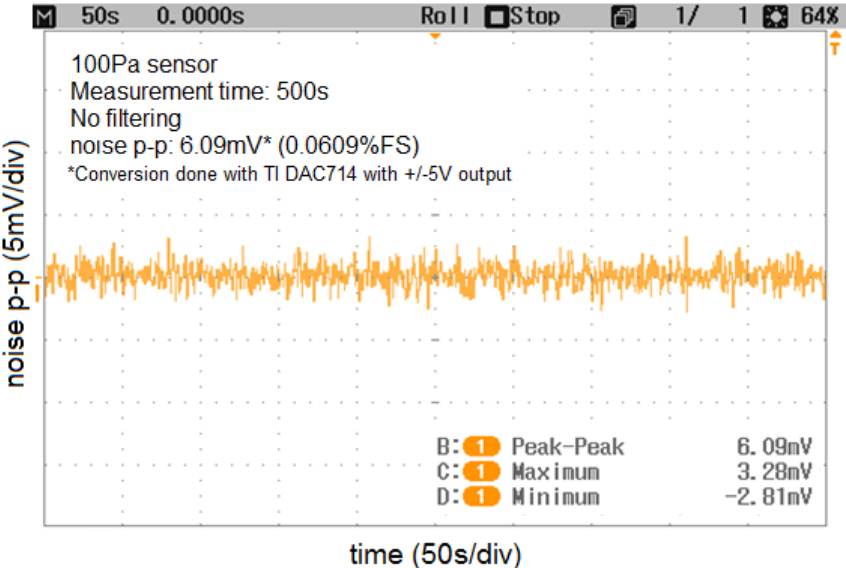

Fig. 3: Typical noise plot of a 100 Pa LMI sensor

LMI series – digital low differential pressure sensors

I²C bus interface specifications

Introduction

The LMI serial interface operates using a standard 2-wire I²C bus. For detailed specifications of the I²C protocol, see UM10204 - I²C Bus Specification and User Manual from NXP.

Care should be taken to ensure that the sensor is properly connected to the master microcontroller. Refer to the manufacturer's datasheet for more information regarding physical connections.

Signal control

Bus not busy: During idle periods, both data line (SDA) and clock line (SCL) remain HIGH.

START condition (S): A HIGH to LOW transition of SDA while SCL is HIGH is interpreted as START condition. START conditions are always generated by the master. Each initial request for a pressure value has to begin with a START condition.

STOP condition (P): A LOW to HIGH transition of SDA while SCL is HIGH defines a STOP condition. STOP conditions are always generated by the master. More than one request for the current pressure value can be transmitted without generation of intermediate STOP conditions.

DATA valid (D): The state of SDA represents valid data when, after a START condition, SDA is stable for the duration of a HIGH period of SCL. SDA should only change during a LOW period of SCL. There is one SCL pulse per bit of data.

Acknowledge (A): Data are transferred as bytes (i.e., 8 bits) on the serial bus, most-significant-bit (MSB) first. After each byte, the receiving device – master or slave – is obliged to pull SDA LOW to acknowledge the reception of data. The master device must generate an extra clock pulse for this purpose. When acknowledge is missed, the slave transmitter becomes inactive. The master device must either re-send the last command, or generate a STOP condition in this case.

Slave address: The I²C-bus master-slave concept requires a unique address for each device. The LMI device's address is modifiable based on the connection of the ADRO and ADR1 pins. ADRx connected to GND represents logic-0, whereas a connection to VS represents logic-1. This allows for four unique assignable addresses:

Base address (binary)	ADR1	ADRO	7-bit I ² C address (binary)	7-bit I ² C address (hexadecimal)
10111	0	0	1011100	0x5C
	0	1	1011101	0x5D
	1	0	1011110	0x5E
	1	1	1011111	0x5F

After generating a START condition, the master sends the address byte containing the 7-bit address, followed by a data direction bit (R/W). A "0" indicates a transmission from master to slave (WRITE), a "1" indicates a data request (READ).

MSB						LSB	
1	0	1	1	1	ADR1	ADRO	R/W

DATA operation: The sensor starts to send 2 data bytes containing the current pressure value (shown in Fig. 4 as "Readout of result").

LMI series – digital low differential pressure sensors

I²C bus interface specifications (cont.)

I²C command set

The LMI device implements the following commands:

Command	Description	Type	Bytes to read from LMI
0x11	Reset firmware	W	N/A
0x20	Start conversion	W/R	2

Reset firmware

Writing this command to the LMI device resets the firmware's program counter. The LMI device does not return any data to be read.

```

/* ===== PSEUDOCODE - RESET FIRMWARE ===== */
// Assumption: The sensor's address is defined with ADR0 = ADR1 = 0.
byte sensorAddress = 0x5c;
byte resetCommand = 0x11;

// Write the command to the bus.
i2c.sendStartCondition();
i2c.beginTransactionToAddress(sensorAddress); // Send 0xB8 (0x5C with R/W=0).
i2c.writeCommandToBus(resetCommand);       // Send 0x11.
i2c.sendStopCondition();
    
```

Start conversion

Writing this command to the LMI device starts a conversion of pressure data. When the conversion is complete, the LMI device returns the pressure data in two bytes. The 15-bit conversion result is clocked out least-significant byte first:

Low byte								High byte							
MSB							LSB	MSB							LSB
D7	D6	D5	D4	D3	D2	D1	R	D15	D14	D13	D12	D11	D10	D9	D8

Data are delivered in two's complement format; the R bit is reserved.

Ensure that the bytes are re-ordered and that the R bit is dropped for the correct result:

High byte								Low byte							
MSB							LSB	MSB							LSB
0	D15	D14	D13	D12	D11	D10	D9	D8	D7	D6	D5	D4	D3	D2	D1

This command wakes the device from sleep and starts a conversion. This conversion-start command only needs to be sent once; consecutive I²C read commands (i.e., the sensor address with the R/W bit set to "1" may be sent to continuously acquire new data from the device.

LMI series – digital low differential pressure sensors

I²C bus interface specifications (cont.)

```

/* ===== PSEUDOCODE - START CONVERSION ===== */
// The delay between consecutive read commands determines whether or not the
// device works in Continuous or low-power mode.

// Assumption: The sensor's address is defined with ADR0 = ADR1 = 0.
byte sensorAddress = 0x5c;
byte startConversionCommand = 0x20;
byte lowByte, highByte;
short pressureDataInCounts;

// Write the command to the bus (not shown in Fig. 4).
i2c.sendStartCondition();
i2c.beginTransactionTo(sensorAddress); // Send 0xB8 (0x5C with R/W bit = 0).
i2c.writeByte(startConversionCommand); // Send 0x20.
i2c.sendStopCondition();

// Read the result from the LMI device.
i2c.sendStartCondition();
/* ----- READ1 in Fig. 4 ----- */
i2c.requestDataFrom(sensorAddress); // Send 0xB9 (0x5C with R/W bit = 1).
/* ---- RESULT1 in Fig. 4 ---- */
lowByte = i2c.readByte(); // Read first byte returned by sensor.
highByte = i2c.readByte(); // Read second byte returned by sensor.
i2c.sendStopCondition();

// Read the result again from the LMI device.
i2c.sendStartCondition();
/* ----- READ2 in Fig. 4 ----- */
i2c.requestDataFrom(sensorAddress); // Send 0xB9 (0x5C with R/W bit = 1).
/* ---- RESULT2 in Fig. 4 ---- */
lowByte = i2c.readByte(); // Read first byte returned by sensor.
highByte = i2c.readByte(); // Read second byte returned by sensor.
i2c.sendStopCondition();

// Repeat read steps as necessary.

```

LMI series – digital low differential pressure sensors

I²C bus interface specifications (cont.)

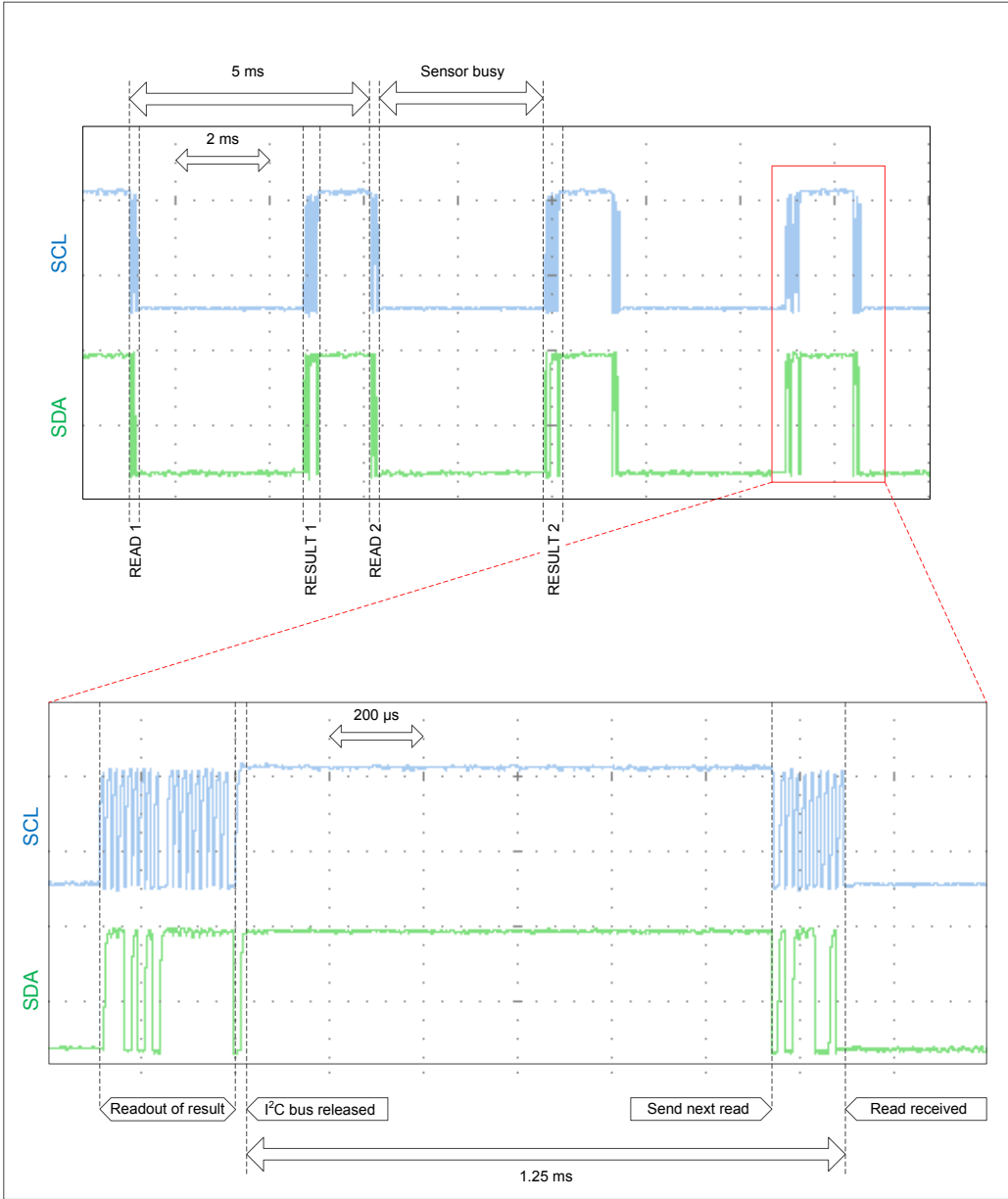

Fig. 4: Continuous mode operation

LMI series – digital low differential pressure sensors

I²C bus interface specifications (cont.)

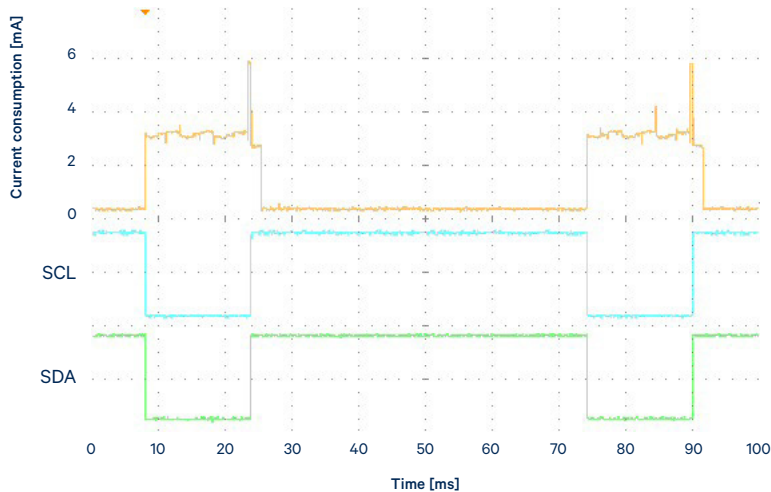

Fig. 5: Low-power mode

Continuous vs low-power mode operation

LMI offers two modes of operation: Continuous mode, which provides a near-continuous stream of pressure data, and low-power mode, which wakes the device from sleep to serve pressure data “on-demand”. The first measurement in either mode is available after a warm-up and conversion sequence, which takes approximately 25 ms. The device holds the SCL line low during warm-up and conversion, effectively blocking the I²C bus during this time.

In continuous mode, the user should consider handling the read-in pressure result from the sensor after having sent the next read command. In Fig. 4, this suggests reading in RESULT 1, sending READ 2, and only then processing RESULT 1 as appropriate (e.g. to update a display or perform complex calculations). This will help ensure that the time between the release of the I²C bus and the sending in full of the next read command is as short as possible.

Continuous mode and low-power mode differ only in how quickly subsequent I²C read commands (i.e., the sensor address with the R/W bit set to 1) are sent to the device. Specifically, if the time between the sensor releasing the bus and the time it receives an I²C read command is 1.25 ms or less (1 ms is a conservative maximum), the device enters Continuous mode, which prevents the device from sleeping between conversions. Fresh data are available every 5 ms in this mode of operation.

Conversely, if the time between releasing the bus and receiving the next I²C read command is greater than 1 ms, the device enters low-power mode and returns to sleep until such time as the next I²C read command is fully clocked in. So long as power remains available, the start-conversion command (0x20) does not need to be re-sent.

LMI series – digital low differential pressure sensors

Dimensional drawing

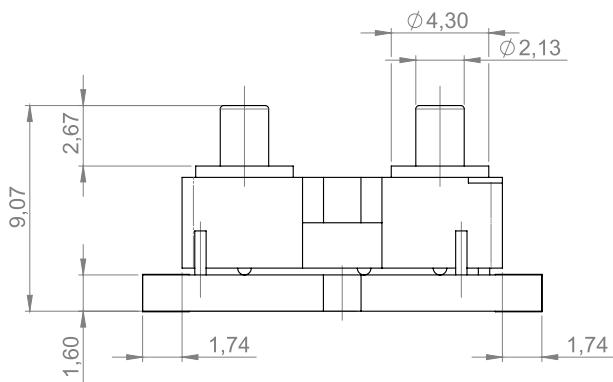

Sensor PCB footprint

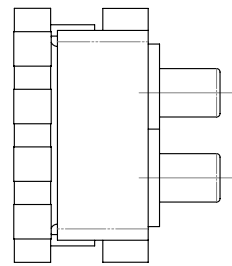
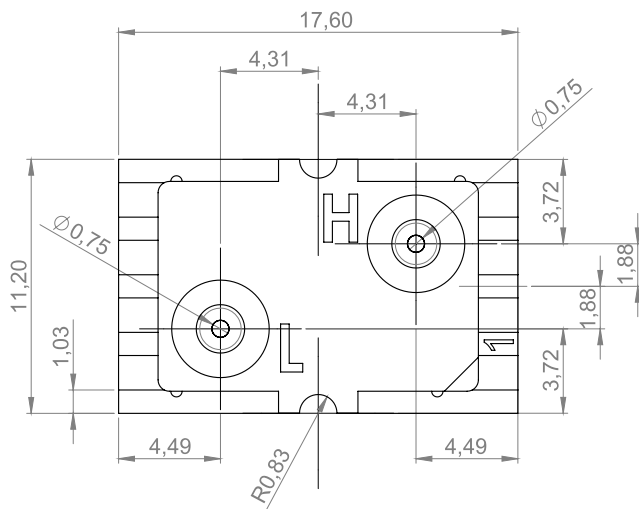
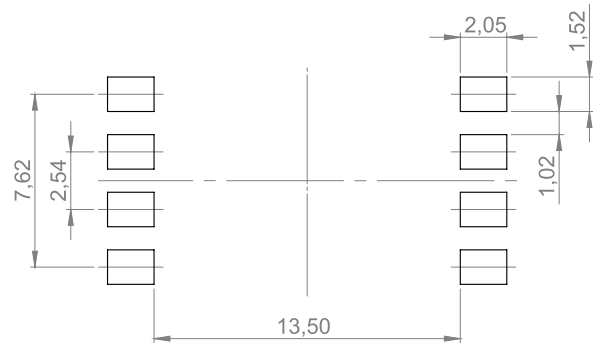

dimensions in mm

Electrical connection

Pin	Function
1	Reserved
2	Reserved
3	GND
4	V_s
5	ADRO
6	ADR1
7	SCL
8	SDA

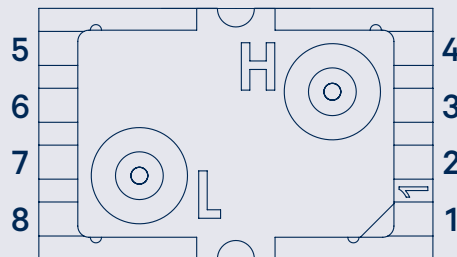

LMI series – digital low differential pressure sensors

Manifold diagram for two side-by-side mounted sensors

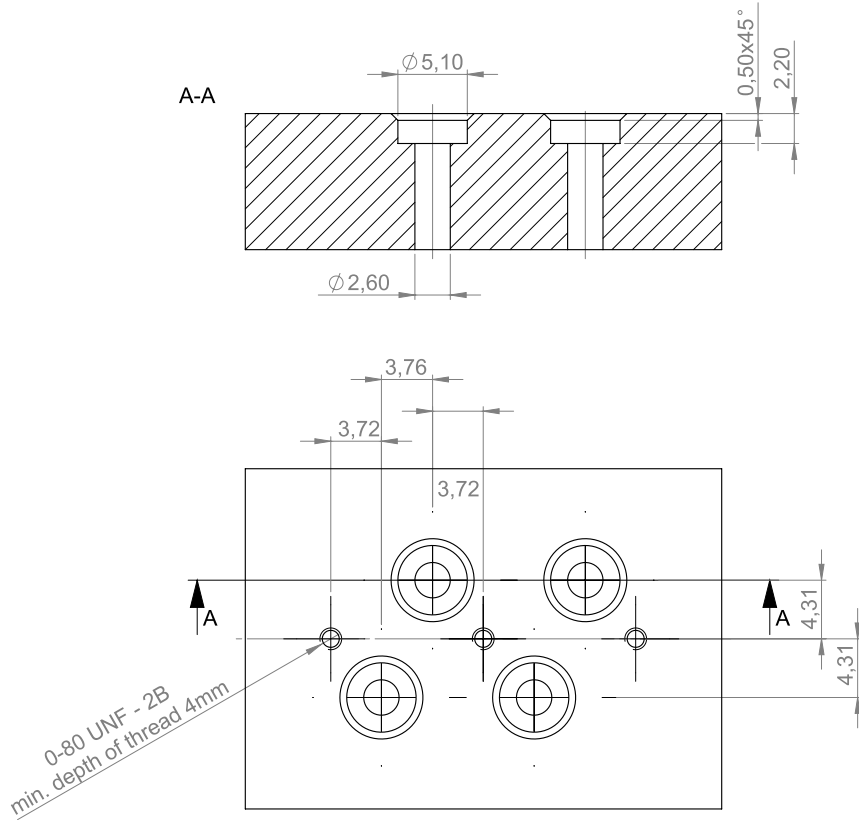

Recommended O-rings:
Part number: 90025K119
www.mcmaster.com

dimensions in mm

Manifold diagram for multiple side-by-side mounted sensors

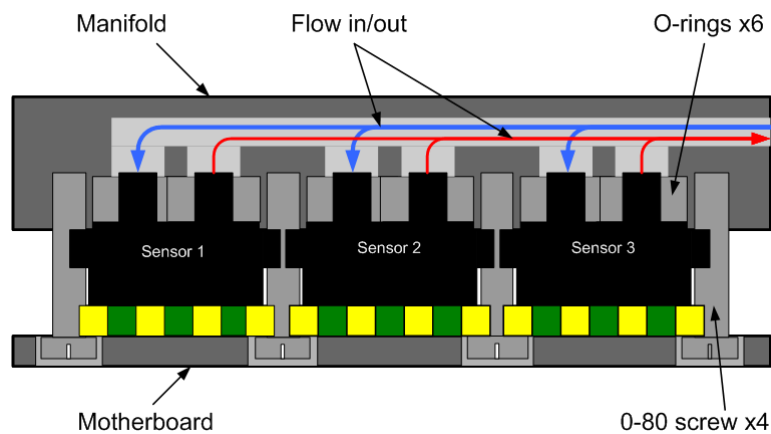

LMI series – digital low differential pressure sensors

Custom adaptor

The LMI series pressure sensors can optionally be equipped with a custom adaptor for your application-specific mounting requirements. Please contact First Sensor for more information.

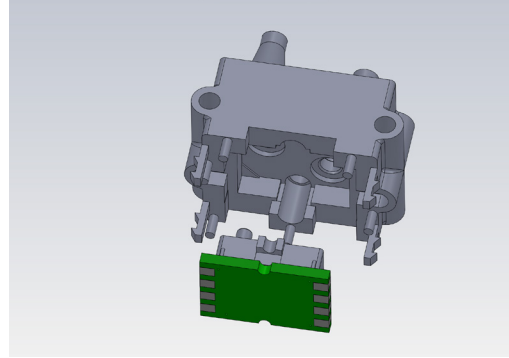
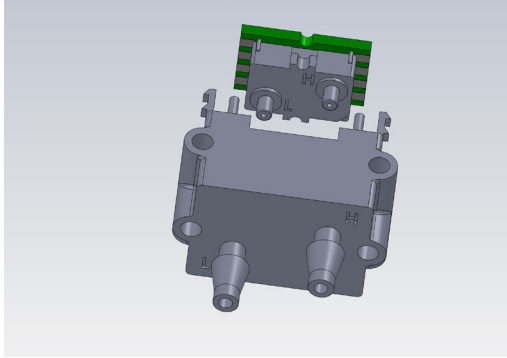

Fig. 7: 3D views of a custom adaptor for the LMI pressure sensor

Gas mixture change (purge time)

The LMI series pressure sensors feature minimized internal volume, which allows for fast response to gas mixture change and high pneumatic impedance at the same time. Purge time (T_p) can be estimated by the following equation:

$$T_p = \frac{V_{INT}}{F_{Nom}} = \frac{V_{INT}}{P_{Nom}/Z_p}$$

- T_p = Purge time [s]
- V_{INT} = Internal volume of the LMI sensor [ml]
- F_{Nom} = Nominal flow [ml/s]
- P_{Nom} = Nominal pressure [Pa]
- Z_p = Pneumatic impedance [kPa/(ml/s)]

The typical internal volume of the LMI sensor (V_{INT}) is 0.04 ml. With a pneumatic impedance (Z_p) of 15 kPa/(ml/s) and a nominal pressure (P_{Nom}) of 250 Pa, the estimated purge time (T_p) is 2.4 seconds.

Ordering information

Series	Pressure range		Calibration		Housing	Output	Grade
LMI	S025	25 Pa (0.1 inH ₂ O)	B	Bidirectional	B [SMD, 2 ports, axial, same side]	3 [Non-ratiometric, 3 V supply]	S [High]
	S050	50 Pa (0.2 inH ₂ O)	U	Unidirectional			
	S100	100 Pa (0.4 inH ₂ O)					
	S250	250 Pa (1 inH ₂ O)					
	S500	500 Pa (2 inH ₂ O)					