

HMI series – amplified pressure sensors

The HMI pressure sensors provide digital output signals via a I²C bus interface and utilise precision digital signal conditioning to achieve high accuracies. The sensors offer an increased media compatibility to measure gases and liquids. 5 V and 3 V supply versions are available. Very small SIL and DIP housings allow for space-saving PCB-mounting. All HMI pressure sensors can be modified according to customer specific requirements.

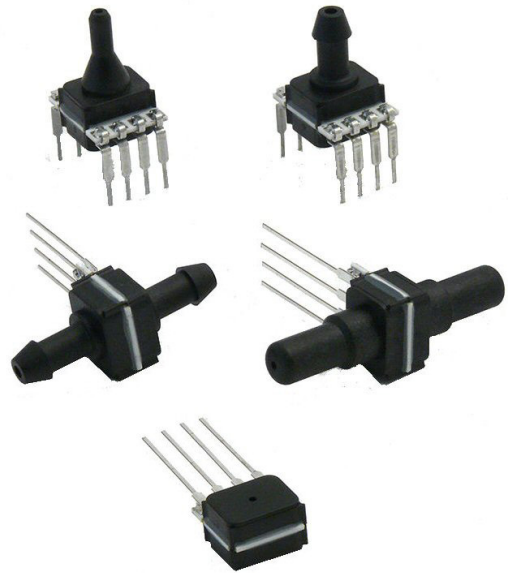

Features

- Pressure ranges from 2.5 mbar to 1 bar, 1 psi to 150 psi gage or differential pressure
- Increased media compatibility⁽¹⁾
- Digital I²C bus output
- Precision ASIC signal conditioning
- Calibrated and temperature compensated⁽²⁾
- SIL and DIP housings

Certificates

- Quality Management System according to EN ISO 13485:2003 and EN ISO 9001:2008
- RoHS and REACH compliant

Media compatibility

High pressure port:

To be used with gases and liquids which are compatible with the wetted materials (high temperature polyamide, ceramic AL₂O₃, epoxy, fluorosilicone, glass, silicon).

Low pressure port:

To be used with non-corrosive, non-ionic working fluids such as clean dry air, dry gases and the like.

Applications

- Industrial controls
- Pneumatic controls
- Environmental controls
- HVAC
- Instrumentation
- Analytical instruments
- Medical devices

Specification notes

(1) All wetted materials are selected to give a high level of media compatibility. Media compatibility refers to media inside the pressure port and lid. Improved media compatibility on high pressure port (backward side of sensor chip) since media has no contact to electronic components. Nevertheless tests with the media used in the specific application are recommended.

(2) Sensor is calibrated in air, changes in sensor behaviour based on physical effects caused by the specific media can occur. Weight of the media and wetting forces can influence the sensor characteristics.

HMI series – amplified pressure sensors

Maximum ratings

Parameter		Min.	Typ.	Max.	Unit
Supply voltage (V_s) ⁽³⁾	HMI...3	2.7	3.0	4.2	V_{dc}
	HMI...5	4.2	5.0	5.5	
Output current	Sink		1		mA
	Source		1		
Temperature ranges	Compensated	-20		+85	°C
	Operating	-20		+85	
	Storage ⁽⁴⁾	-40		+125	
Humidity limits (non-condensing) ⁽⁵⁾				95	%RH
Vibration	10...2000 Hz, random (EN 60068-2-64)			10	g
Mechanical shock	11 ms (EN60068-2-27)			50	
Lead solder temperature	(JESD22-B106D)			270	°C

Pressure sensor characteristics

Part no.	Operating pressure	Proof pressure ⁽⁶⁾
HMIM2x5U...	0...2.5 mbar	100 mbar
HMIM2x5B...	0...±2.5 mbar	
HMIM005U...	0...5 mbar	
HMIM005B...	0...±5 mbar	
HMIM010U...	0...10 mbar	300 mbar
HMIM010B...	0...±10 mbar	
HMIM020U...	0...20 mbar	
HMIM020B...	0...±20 mbar	
HMIM050U...	0...50 mbar	2 bar
HMIM050B...	0...±50 mbar	
HMIM100U...	0...100 mbar	
HMIM100B...	0...±100 mbar	
HMIM250U...	0...250 mbar	10 bar
HMIM250B...	0...±250 mbar	
HMIB001U...	0...1 bar	5 bar
HMIB001B...	0...±1 bar	
HMIB2x5U...	0...2.5 bar	10 bar
HMIB005U...	0...5 bar	14 bar
HMIB010U...	0...10 bar	
HMIP001U...	0...1 psi	30 psi
HMIP001B...	0...±1 psi	
HMIP100U...	0...100 psi	200 psi

Other pressure ranges are available on request. Please contact First Sensor.

Specification notes

(3) The sensor might not function or be operable above an absolute maximum rating of $V_s=6.5$ V.

(4) Storage temperature of the sensor without package.

(5) Tested 1h, up to 85 °C. 100 % condensing or direct liquid media on high pressure port.

(6) Proof pressure is the maximum pressure which may be applied without causing durable shifts of the electrical parameters of the sensing element.

HMI series – amplified pressure sensors

Performance characteristics ⁽⁷⁾

(T_A=25 °C, RH=50 %,

for HMI...3 devices (V_S=3.0 V_{DC}) digital output signal is non-ratiometric to V_S in the range of V_S =2.7...4.2 V,

for HMI...5 devices (V_S=5.0 V_{DC}) digital output signal is non-ratiometric to V_S in the range of V_S =4.2...5.5 V)

Parameter		Min.	Typ.	Max.	Unit
Non-linearity (-20...85 °C) ⁽⁸⁾				±0.25	
Accuracy ⁽⁹⁾				±0.25	
Total accuracy (-20...85 °C) ⁽¹⁰⁾	up to 5 mbar			±2	%FSS
	10 mbar to 50			±1.25	
	all others			±0.75	
Response delay ⁽¹¹⁾			0.5		ms
A/D resolution			12		bit
D/A resolution				11	
Current consumption	5 V devices	<1 bar	4.2		mA
		all others	5.3		
	3 V devices	<1 bar	3.7		
		all others	4.5		

Pressure ranges up to 5 mbar

Unidirectional devices

Parameter	Min.	Typ.	Max.	Unit
Zero pressure offset	2460	3000	3540	
Full scale span (FSS) ⁽¹²⁾		27000		counts
Full scale output	29460	30000	30540	

Bidirectional devices

Parameter	Min.	Typ.	Max.	Unit
Zero pressure offset	15960	16500	17040	
Full scale span (FSS) ⁽¹²⁾		27000		counts
Full scale output	@ max. specified pressure	29460	30000	30540
	@ min. specified pressure	2460	3000	3540

Specification notes (cont.)

(7) Sensor is calibrated in air, changes in sensor behaviour based on physical effects caused by the specific media can occur. Weight of the media and wetting forces can influence the sensor characteristics.

(8) Non-linearity is the measured deviation based on Best Fit Straight Line (BFSL).

(9) Accuracy is the combined error from non-linearity and hysteresis. Hysteresis is the maximum output difference at any point within the operating pressure range for increasing and decreasing pressure.

(10) Total accuracy is the combined error from offset and span calibration, non-linearity, pressure hysteresis, and temperature effects. Calibration errors include the deviation of offset and full scale from nominal values.

(11) Max. delay time between pressure change at the pressure die and signal change at the output.

(12) Full Scale Span (FSS) is the algebraic difference between the output signal for the highest and lowest specified pressure.

HMI series – amplified pressure sensors

Performance characteristics (cont.)⁽⁷⁾

(T_A=25 °C, RH=50 %,

for HMI...3 devices (V_S=3.0 V_{DC}) digital output signal is non-ratiometric to VS in the range of V_S =2.7...4.2 V,

for HMI...5 devices (V_S=5.0 V_{DC}) digital output signal is non-ratiometric to VS in the range of V_S =4.2...5.5 V)

Pressure ranges from 10 mbar to 50 mbar / 1 psi

Unidirectional devices

Parameter	Min.	Typ.	Max.	Unit
Zero pressure offset	2663	3000	3338	
Full scale span (FSS) ⁽¹²⁾		27000		counts
Full scale output	29663	30000	30338	

Bidirectional devices

Parameter	Min.	Typ.	Max.	Unit	
Zero pressure offset	16163	16500	17040		
Full scale span (FSS) ⁽¹²⁾		27000		counts	
Full scale output	@ max. specified pressure	29663	30000	30338	
	@ min. specified pressure	2663	3000	3338	

All other pressure ranges

Unidirectional devices

Parameter	Min.	Typ.	Max.	Unit
Zero pressure offset	2798	3000	3203	
Full scale span (FSS) ⁽¹²⁾		27000		counts
Full scale output	29798	30000	30203	

Bidirectional devices

Parameter	Min.	Typ.	Max.	Unit	
Zero pressure offset	16298	16500	16703		
Full scale span (FSS) ⁽¹²⁾		27000		counts	
Full scale output	@ max. specified pressure	29798	30000	30203	
	@ min. specified pressure	2798	3000	3203	

Specification notes (cont.)

(7) Sensor is calibrated in air, changes in sensor behaviour based on physical effects caused by the specific media can occur. Weight of the media and wetting forces can influence the sensor characteristics.

(12) Full Scale Span (FSS) is the algebraic difference between the output signal for the highest and lowest specified pressure.

HMI series – amplified pressure sensors

I²C Bus

Introduction

The HMI is capable to generate a digital output signal. The device runs a cyclic program, which will store a corrected pressure value with 12 bit resolution about every 250 s within the output registers of the internal ASIC. In order to use the sensor for digital signal readout, it should be connected to a bidirectional I²C-bus.

According to the I²C-bus specification, the bus is controlled by a master device, which generates the clock signal, controls the bus access and generates START and STOP conditions. The HMI is designed to work as a slave, hence it will only respond to requests from a master device.

Digital I²C interface

The HMI complies with the following protocol (Fig. 1):

Bus not busy: During idle periods both data line (SDA) and clock line (SCL) remain HIGH.

START condition (S): HIGH to LOW transition of SDA line while clock (SCL) is HIGH is interpreted as START condition. START conditions are always generated by the master. Each initial request for a pressure value has to begin with a START condition.

STOP condition (P): LOW to HIGH transition of SDA line while clock (SCL) is HIGH determines STOP condition. STOP conditions are always generated by the master. More than one request for the current pressure value can be transmitted without generation of intermediate STOP condition.

DATA valid (D): State of data line represents valid data when, after START condition, data line is stable for duration of HIGH period of clock signal. Data on line must be changed during LOW period of clock signal. There is one clock pulse per bit of data.

Acknowledge (A): Data is transferred in pieces of 8 bits (1 byte) on serial bus, MSB first. After each byte receiving device – whether master or slave – is obliged to pull data line LOW as acknowledge for reception of data. Master must generate an extra clock pulse for this purpose. When acknowledge is missed, slave transmitter becomes inactive. It is on master either to send last command again or to generate STOP condition in that case.

Slave address: The I²C-bus master-slave concept requires a unique address for each device. The HMI has a preconfigured slave address (1111000xb). By factory programming it is possible to define a secondary slave address additional to the general one. According to I²C specification 127 different addresses are available. The sensor will then listen to both slave addresses. After generating a START condition the master sends the address byte containing a 7 bit address followed by a data direction bit (R/W). A "0" indicates a transmission from master to slave (WRITE), a "1" indicates a data request (READ).

DATA operation: The sensor starts to send 2 data bytes containing the current pressure value as a 15 bit information placed in the output registers.

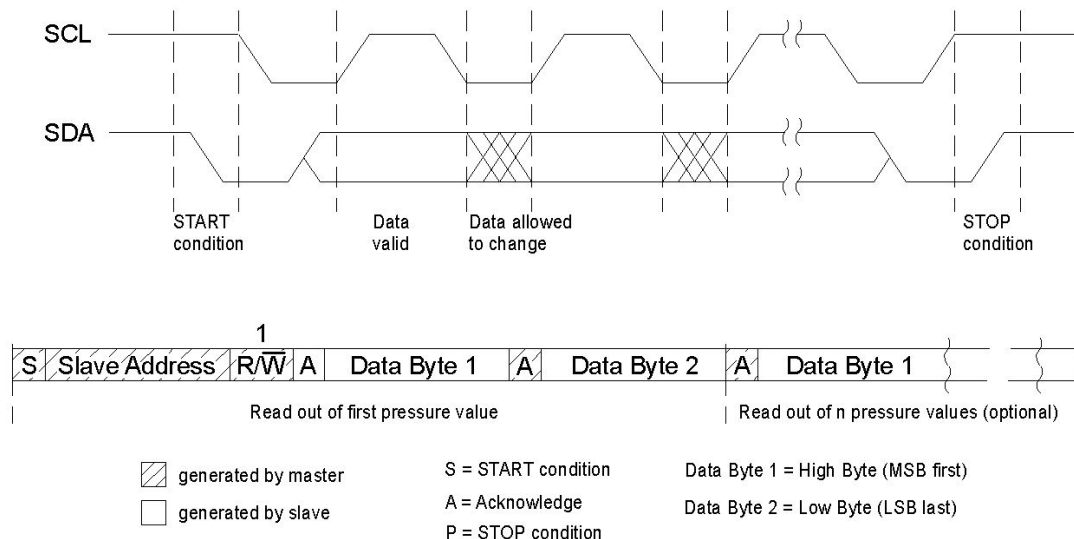

Fig. 1: I²C bus protocol

HMI series – amplified pressure sensors

I²C Interface parameters

Parameter		Min.	Typ.	Max.	Unit
Input high level		90		100	
Input low level		0		10	% of V _s
Output low level				10	
Pull-up resistor		1		5	kΩ
Load capacitance @ SDA	C _{SDA}			400	pF
Input capacitance @ SDA/SCL	C _{I2C_IN}			10	
SCL clock frequency	F _{SCL}	100*		400	kHz
Bus free time between STOP and START condition	t _{BUF}	1.3			
Hold time (repeated) START condition, to first clock pulse	t _{HD,STA}	0.8			
LOW period of SCL	t _{LOW}	1.3			
HIGH period of SCL	t _{HIGH}	0.6			
Setup time repeated START condition	t _{SU,STA}	1			μs
Data hold time	t _{HD,DAT}	0			
Data setup time	t _{SU,DAT}	0.2			
Rise time of both SDA and SCL	t _R			0.3	
Fall time of both SDA and SCL	t _F			0.3	
Setup time for STOP condition	t _{SU,STO}	0.6			

* recommended

Note: First Sensor recommends communication speeds of at least 100 kHz (max. 400 kHz).
Please contact your nearest First Sensor sales office for further information.

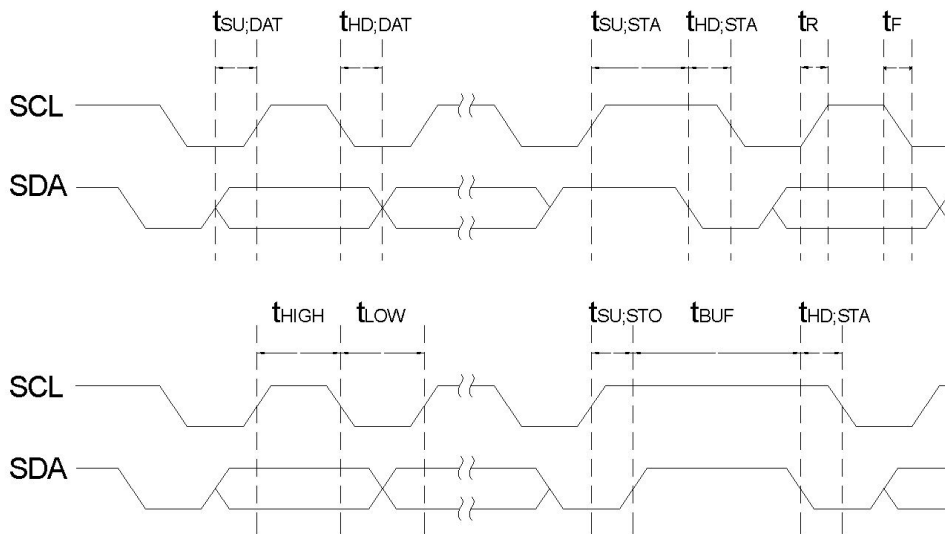

Fig. 2: Timing characteristics

HMI series – amplified pressure sensors

Dimensional drawing

Electrical connection

HMI...U1... (SIL, axial no ports)

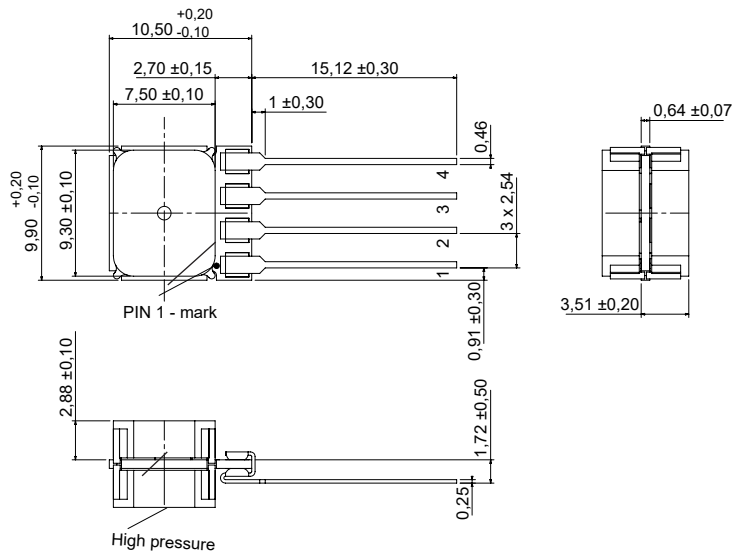

Pin	connection
1	+Vs
2	GND
3	SCL
4	SDA

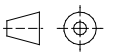

first angle projection
dimensions in mm

HMI...W1... (DIP, axial no ports)

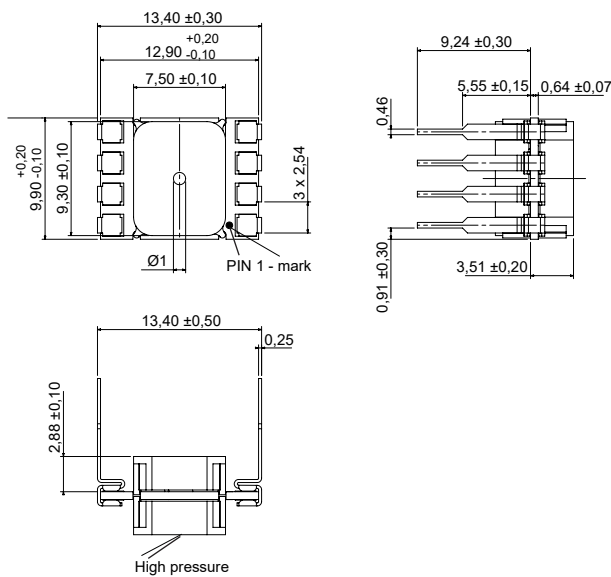

Pin	connection
1	+Vs
2	GND
3	C
4	I/C*
5	SCL
6	I/C*
7	I/C*
8	SDA

* internal connection. Do not connect for any reason

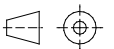

first angle projection
dimensions in mm

HMI series – amplified pressure sensors

Dimensional drawing

HMI...X7... (SIL, 1 port axial, barbed)

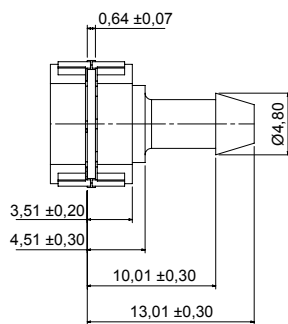
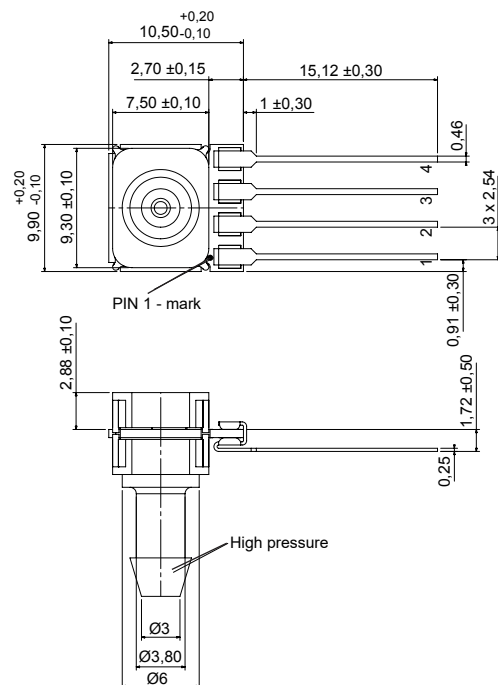

Electrical connection

Pin	connection
1	+Vs
2	GND
3	SCL
4	SDA

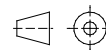

first angle projection
dimensions in mm

HMI...U7... (SIL, 2 ports axial, opposite side, barbed)

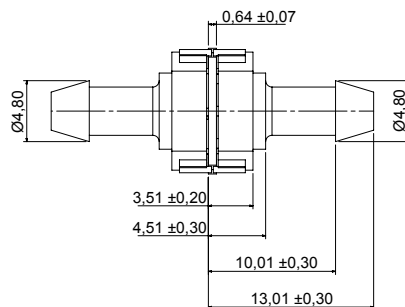
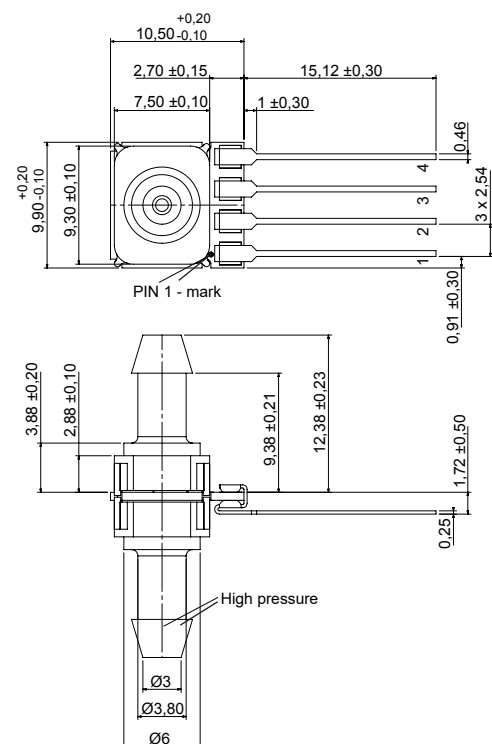

Pin	connection
1	+Vs
2	GND
3	SCL
4	SDA

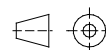

first angle projection
dimensions in mm

HMI series – amplified pressure sensors

Dimensional drawing

HMI...Z7... (DIP, 1 port axial, barbed)

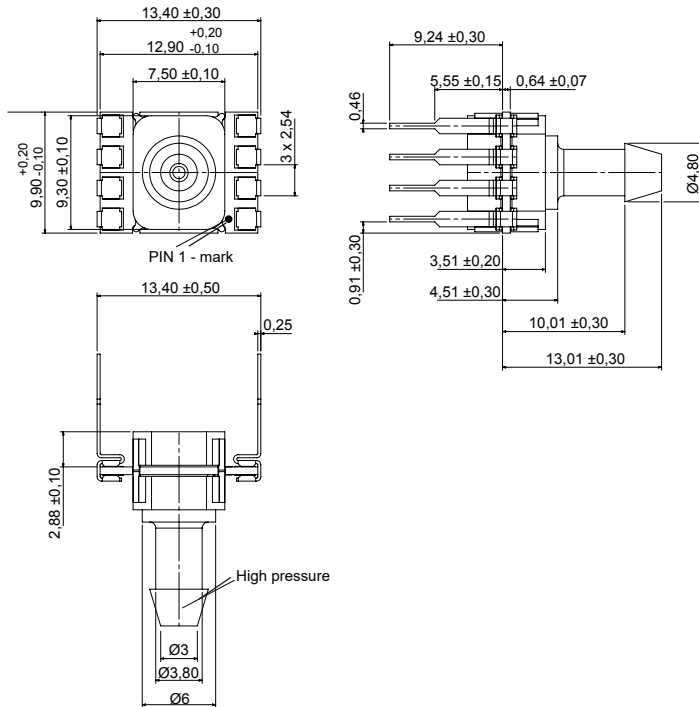

Electrical connection

Pin	connection
1	+Vs
2	GND
3	C
4	I/C*
5	SCL
6	I/C*
7	I/C*
8	SDA

* internal connection. Do not connect for any reason

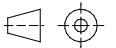

first angle projection
dimensions in mm

HMI...U6... (SIL, 2 ports axial, opposite side, straight big)

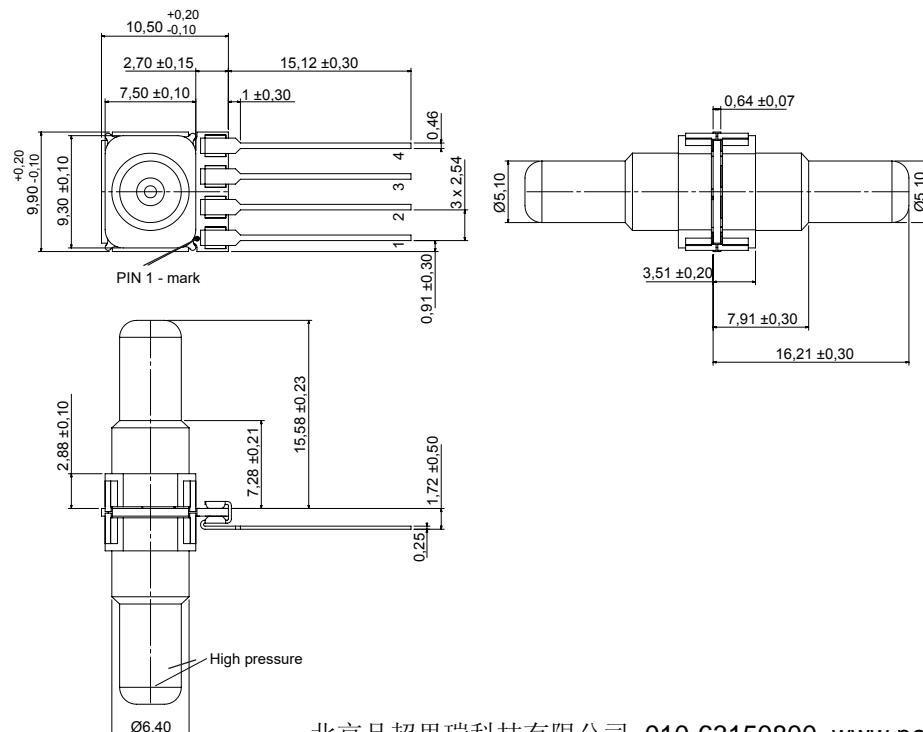

Pin	connection
1	+Vs
2	GND
3	SCL
4	SDA

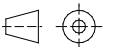

first angle projection
dimensions in mm

HMI series – amplified pressure sensors

Dimensional drawing

Electrical connection

HMI...X6... (SIL, 1 port axial, straight big)

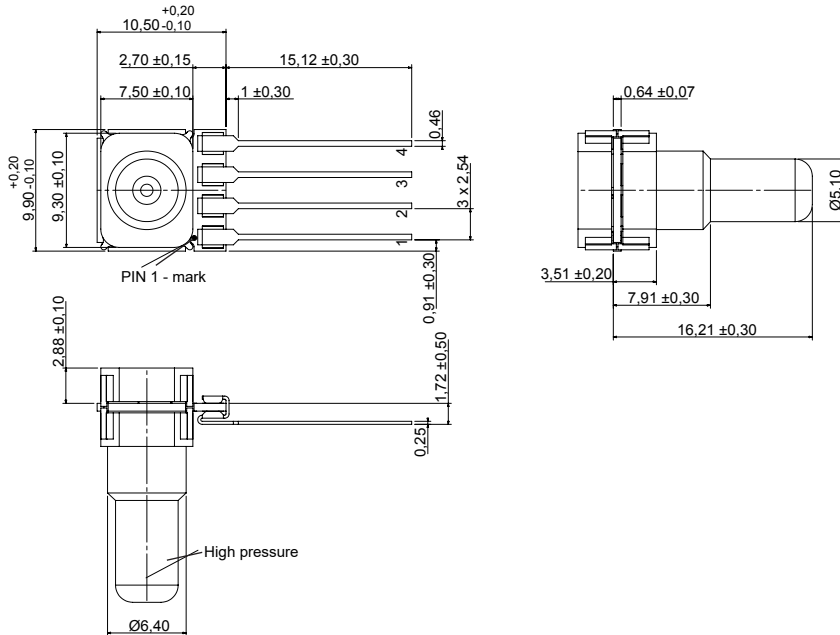

Pin	connection
1	+Vs
2	GND
3	SCL
4	SDA

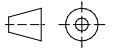

first angle projection
dimensions in mm

HMI...Z6... (DIP, 1 port axial, straight big)

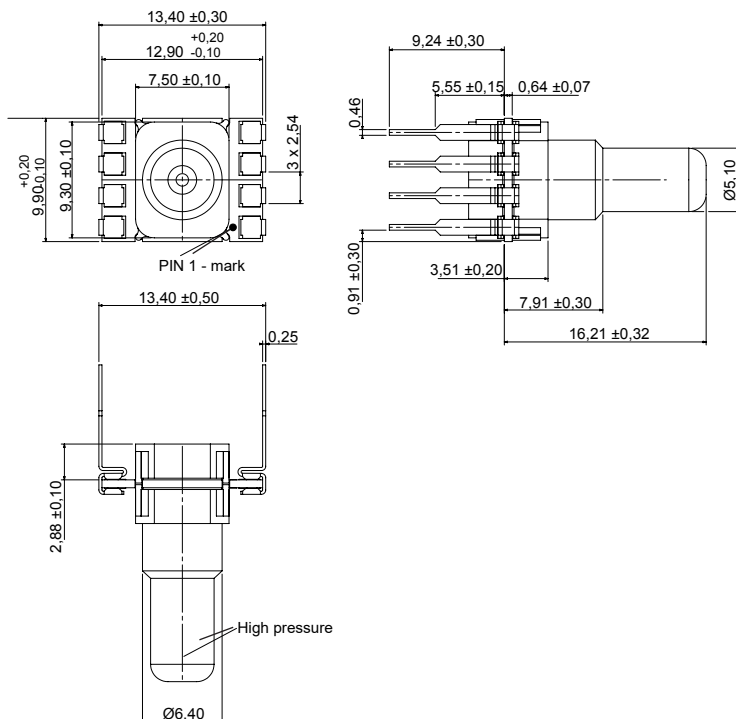

Pin	connection
1	+Vs
2	GND
3	C
4	I/C*
5	SCL
6	I/C*
7	I/C*
8	SDA

* internal connection. Do not connect for any reason

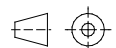

first angle projection
dimensions in mm

HMI series – amplified pressure sensors

Dimensional drawing

Electrical connection

HMI...U5... (SIL, 2 ports axial, opposite side, needle big)

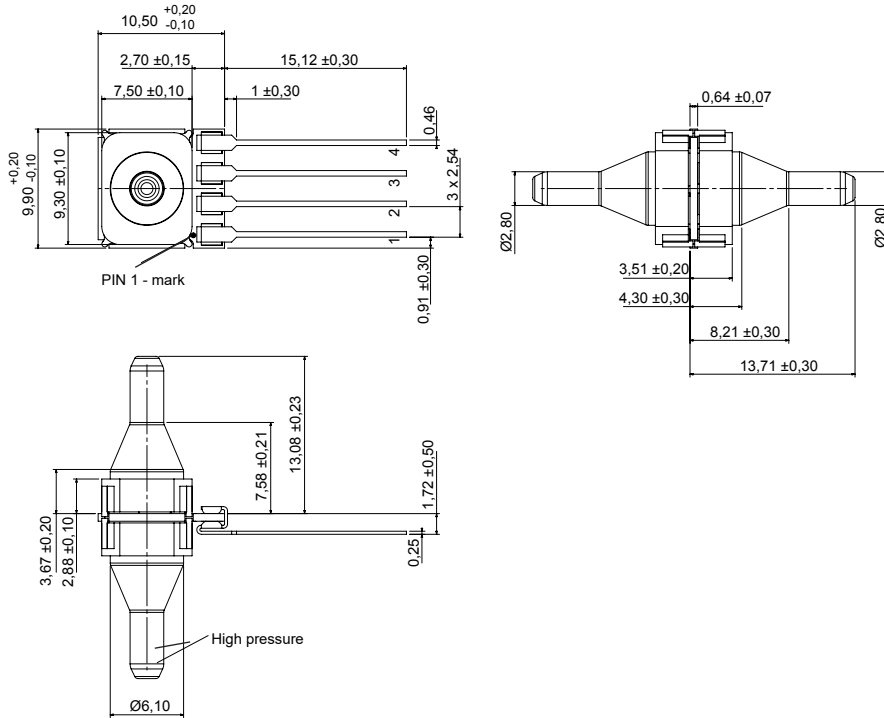

Pin	connection
1	+Vs
2	GND
3	SCL
4	SDA

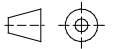

first angle projection
dimensions in mm

HMI...X5... (SIL, 1 port axial, needle big)

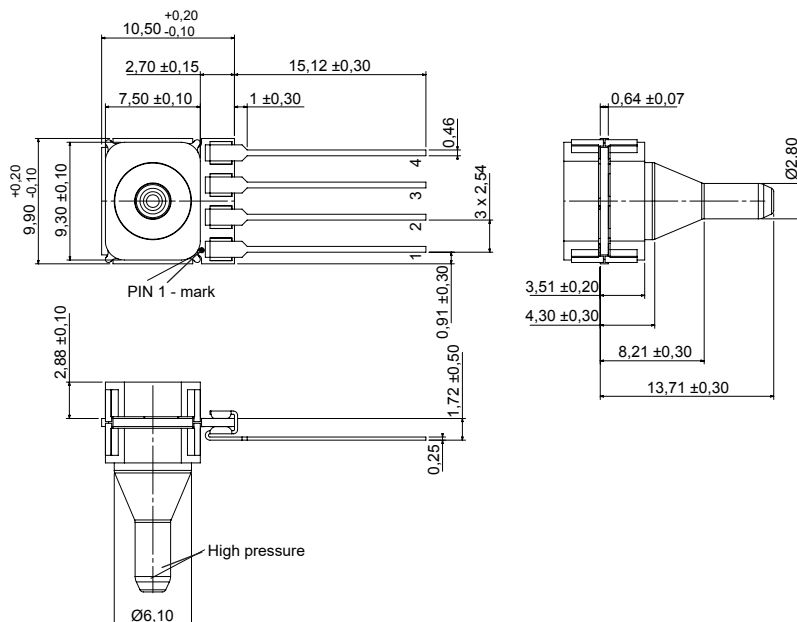

Pin	connection
1	+Vs
2	GND
3	SCL
4	SDA

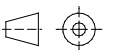

first angle projection
dimensions in mm

HMI series – amplified pressure sensors

Dimensional drawing

Electrical connection

HMI...Z5... (DIP, 1 port axial, needle big)

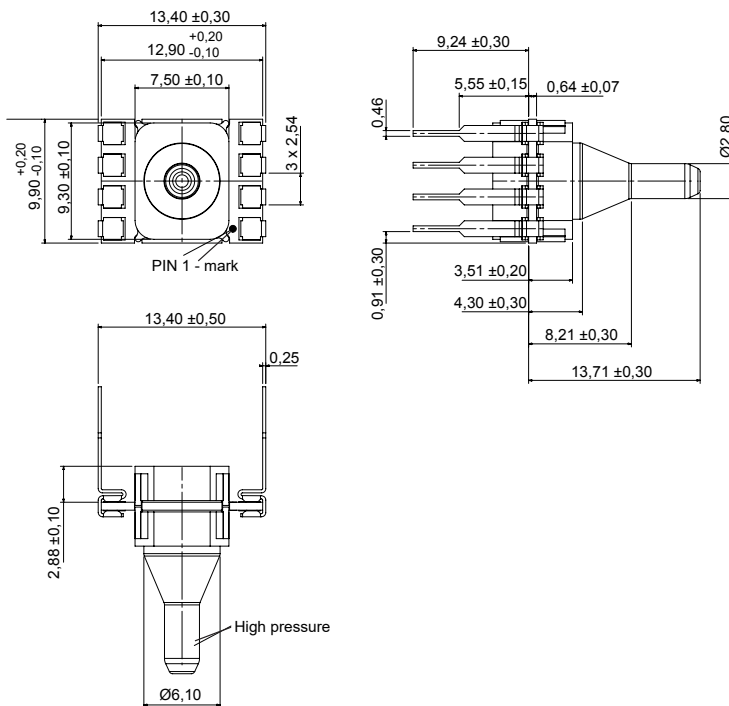

Pin	connection
1	+Vs
2	GND
3	C
4	I/C*
5	SCL
6	I/C*
7	I/C*
8	SDA

* internal connection. Do not connect for any reason

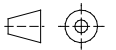

first angle projection
dimensions in mm

Electrical connection (cont.)

DIP versions

SIL versions

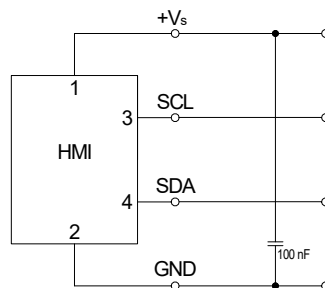
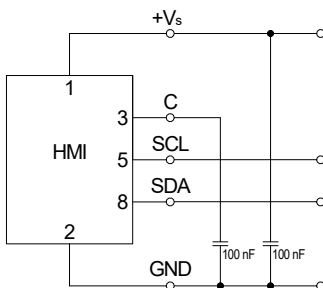

HMI series – amplified pressure sensors

Ordering information

Series	Pressure range	Calibration	Housing	Porting	Grade	Voltage	
HMI	M2x5	2.5 mbar	B Bidirectional	U [SIL, 2 ports axial, opposite side]	1 no port	H High	3 3 V
	M005	5 mbar	U Unidirectional	W [DIP, 2 ports axial, opposite side]	7 Barbed		5 5 V
	M010	10 mbar		X [SIL, 1 port axial]	5 Needle big		
	M020	20 mbar		Z [DIP, 1 port axial]	6 Straight big		
	M050	50 mbar					
	M100	100 mbar					
	M250	250 mbar					
	B001	1 bar					
	B2x5	2.5 bar					
	B005	5 bar					
	B010	10 bar					
	P001	1 psi					
	P100	100 psi					

Order code example: HMIB001BW1H3

Note: Not all possible sensor configurations are active products. MOQ may apply.
 Custom specific pressure and temperature ranges as well as mechanical or electronic sensor modifications are widely available.
 Please contact First Sensor.

Label information

Digit	1	2	3	4	5	6	7	8	9	10	11	12	13	14
	Series		Pressure range	Pressure unit / pressure mode / calibration	Housing	Porting	Grade / voltage	Rev	Date code (year)	Production code				
Char	M	I	HMI	1 2.5 mbar	U bar, gage/differential, unidirectional	U SIL, 2 ports axial, opposite side	1 no port	-	High, 5 V					
			2 5 mbar				7 Barbed	/	High, 3 V					
			3 10 mbar	B bar, gage/differential, bidirectional	W DIP, 2 ports axial, opposite side	5 Needle big								
			4 20 mbar				6 Straight big							
			5 50 mbar		X SIL, 1 port axial									
			6 1 psi		Z DIP, 1 port axial									
			7 100 mbar											
			8 250 mbar											
			A 1 bar											
			B 2.5 bar											
			C 5 bar											
			L 100 psi											
			M 10 bar											